



# **SYSTEM OPERATIONS TRAINING MANUAL**

Originally prepared for WECC by  
KEMA Consulting in 1993

Revised August 2014

Western Electricity Coordinating Council  
155 North 400 West  
Suite 200  
Salt Lake City, Utah 84103-1114  
Web site: [www.wecc.biz](http://www.wecc.biz)  
E-mail: [training@wecc.biz](mailto:training@wecc.biz)

# Table of Contents

## Western Electricity Coordinating Council

### System Operations Training Manual

<b>Preface</b> .....	<b>iii</b>
Using the System Operations Training Guide (PDF) .....	iii
<b>Module 1: Introduction to WECC</b> .....	<b>1-1</b>
Table of Contents .....	1-2
<b>Module 2: Fundamentals of Electricity</b> .....	<b>2-1</b>
Table of Contents .....	2-2
<b>Module 3 Power System Overview</b> .....	<b>3-1</b>
Table of Contents .....	3-2
<b>Module 4 Principles of Power Generation</b> .....	<b>4-1</b>
Table of Contents .....	4-2
<b>Module 5 Substation Overview</b> .....	<b>5-1</b>
Table of Contents .....	5-2
<b>Module 6 Transformers</b> .....	<b>6-1</b>
Table of Contents .....	6-2
<b>Module 7 Power Transmission</b> .....	<b>7-1</b>
Table of Contents .....	7-2
<b>Module 8 System Protection</b> .....	<b>8-1</b>
Table of Contents .....	8-2
<b>Module 9 Principles of Power System Operation</b> .....	<b>9-1</b>
Table of Contents .....	9-2
<b>Glossary and References</b> .....	<b>1</b>
Glossary.....	3
References.....	16

## Preface

The Western Electricity Coordinating Council (WECC) System Operations Training Manual (SOTM) is the manual for the Fundamentals of System Operations training class and is also a self-paced training course. The manual provides you, the WECC system operators, with a basic understanding of electric power and principles. It prepares you to attend additional WECC system operator training sessions.

You can use the training manual as:

- The course manual for the Introduction to System Operations training class.
- A self-paced study guide to provide a basic understanding of power system operations.
- A reference to brush up on specific power system topics.

The training manual presents general industry practices and is not intended to provide member-specific information.

The manual consists of nine modules, a glossary, and a reference list.

### Using the System Operations Training Guide (PDF)

The PDF version of the SOTM has been built with some accessibility features. The Table of Contents (TOC) is hyperlinked. To display a page, click on that line in the TOC and the PDF displays the top of the requested page. The if the topic requested is more than half-way down the page, you may need to scroll down to display it. To return to the TOC, click on the “Previous View” icon  on the toolbar at the top of the screen.

**Note:** if the Previous View icon not is on your toolbar, right-click on the toolbar and select [More Tools...](#) When the menu displays, scroll down to the [Page Navigation Toolbar](#) section and click the selection box next to [Previous View](#), then click **OK**. The icon is added to your toolbar.



For anyone who would like to print a copy of the SOTM, this PDF has been formatted to facilitate two-sided printing.

This page intentionally left blank.



**Module 1:  
Introduction to WECC**

**Module 1:  
Introduction to WECC**

**Table of Contents**

**Module 1: Introduction to WECC .....1-3**  
**Section 1-1: WECC’s Mission.....1-4**  
**Section 1-2: WECC’s Organization .....1-6**  
**Section 1-3: WECC’s Electrical System .....1-10**  
**Section 1-4: Reliability Coordination.....1-12**

**Table of Figures**

Figure 1.1: NERC Regions.....1-7  
Figure 1.2: WECC Power Areas.....1-11

## **Module 1: Introduction to WECC**

### **Module Overview**

This Module, Introduction to WECC, presents the role and functions of the Western Electricity Coordinating Council (WECC), and describes the interconnected electrical network WECC represents by discussing the following topics:

- WECC's Mission
- WECC's Organization
- WECC's Electrical System
- Reliability Coordination in the Western Interconnection

The term WECC has two connotations:

- First: WECC refers to the organization that develops regional reliability standards, reviews and enforces compliance, and promotes electric system reliability through delegated operations and planning activities.
- Second: WECC refers to the generators, transmission lines, substations, and other physical facilities making up the interconnected electrical network (the Western Interconnection).

We first review WECC's mission and a brief history of the events leading to WECC's founding. Then we look at the WECC human organization and finally, the electrical network.

## Section 1-1: WECC's Mission

WECC is a 501c(4) non-profit Utah corporation with the mission to foster and promote reliability and efficient coordination in the Western Interconnection. WECC strives the lead the stakeholders in the Western Interconnection to achieve appropriate system reliability, be the premier source of unbiased information, and serve as the trusted thought leader for the Western Interconnection by providing:

- 1) Impartial independent review and analysis of reliability issues impacting the Western Interconnection;
- 2) Development of electric reliability standards incorporating Western Interconnection experience and knowledge;
- 3) Consistent and fair monitoring and enforcement activities for compliance with reliability standards;
- 4) Event analysis and lessons-learned from system events;
- 5) Value for its membership through cost effective and efficient services and practices through:
  - being a centralized repository of reliable information relating to the planning and operation of the Bulk Electric System in the Western Interconnection,
  - coordinating system planning and modeling,
  - sharing of, and providing comment on adherence to, recognized industry best practices,
  - facilitating resolution of market seams and coordination issues,
  - secure sharing of critical reliability data, and
  - providing a robust stakeholder forum.

WECC's coordination is the key factor in maintaining the region's electrical reliability. The ability to transmit power through the interconnected system from one member to another gives all members access to less expensive electricity. In addition, intraregional transmission enables members hundreds of miles apart to help each other when there is a power shortage or emergency.

Power systems have existed in the West since the 1880s. Over time, those systems have interconnected with one another. As energy transfers between systems became larger and more common, it became necessary to perform coordinated technical studies and to coordinate planning and operating activities. Several planning organizations developed, including the Western United States Transmission Study Group and the Pacific Intertie Study Group.

In 1967, utility executives formed the Western Systems Coordinating Council (WSCC) to promote reliability by bringing the region's planning and operating coordination activities under one organization. The WSCC technical staff was established in 1971 to perform planning studies and coordinate WSCC committee activities. The WSCC Dispatcher Training Program was established in 1981 to provide system operator training. The Dispatcher Training Program has provided instruction for more than two decades to thousands of individuals. WECC is certified as a North American Reliability Corporation (NERC)-Approved Continuing Education Provider and continues to provide quality training to NERC-Certified System Operators in the Western Interconnection.

WECC was formed on April 18, 2002, by the merger of the Western Systems Coordinating Council (WSCC), and two regional transmission associates: the Southwest Regional Transmission Association and the Western Regional Transmission Association (WRTA). WSCC, WECC's predecessor was organized in August of 1967 to facilitate electric industry coordination in the planning and operation of the electric system in Western North America.

WECC is one of eight electric reliability councils in North America, and the only one operating in three countries. WECC's footprint encompasses a geographic area equivalent to over half of the United States. The members – representing all segments of the electric industry – provide electricity to people in 14 western states, two Canadian provinces, and part of one Mexican State.

Membership in WECC is open to all entities with an interest in the operation of the bulk electric system in the Western Interconnection. All meetings are open and anyone may participate in WECC's standards development process.

In carrying out its mission to assure a reliable bulk electric power system in the Western Interconnection that supports efficient and competitive electric power markets, WECC performs four organizational roles.

- **Regional Entity** – WECC is required by the U.S. Federal Energy Regulatory Commission (FERC) to monitor and enforce compliance with reliability standards by users, owners, and operators of the bulk power system in the United States.
- **Credible Source of Interconnection-Wide Information** – WECC provides training, education, and information on key functions related to mandatory standards and compliance, as well as data, analysis and studies relating to transmission system planning, and renewables integration. WECC is a conduit for other data exchanges.
- **Western Interconnection- Wide Planning Facilitator** – WECC provides planning functions (transmission planning and integration of resources) and policy-related functions as requested by members.

- **Western Interconnection-Wide Regional Reliability Policy Facilitator –** WECC facilitates the identification of issues specific to reliability, creates an opportunity for discussion of the issues, and represents region-wide issues and policies at the state and federal levels.

## Section 1-2: WECC's Organization

WECC is one of eight NERC Regional Reliability Councils. NERC was formed in 1968 in the aftermath of the November 9, 1965 Northeast Blackout.

Since 1968, NERC has been committed to ensuring the reliability of the bulk power system in North America.

To achieve that, NERC develops and enforces reliability standards; assesses adequacy annually via a 10-year forecast (and winter and summer forecasts); monitors the bulk power system; audits owners, operators, and users for preparedness; and educates, trains, and certifies industry personnel. NERC is a self-regulatory organization, subject to oversight by the U.S. Federal Energy Regulatory Commission and governmental authorities in Canada.

As of June 18, 2007, the FERC granted NERC the legal authority to enforce reliability standards with all U.S. users, owners, and operators of the bulk power system, and made compliance with those standards mandatory and enforceable. Reliability standards are also mandatory and enforceable in Ontario and New Brunswick, and NERC is seeking to achieve comparable results in the other Canadian provinces. NERC will seek recognition in Mexico once the necessary legislation is adopted.

NERC's status as a self-regulatory organization means that it is a non-government organization that has statutory responsibility to regulate bulk power system users, owners, and operators through the adoption and enforcement of standards for fair, ethical, and efficient practices.

The industry, with the assistance of NERC, has created effective reliability standards that are clear, consistent, and technically sound. These standards, coupled with a strong standards enforcement program, form the foundation of NERC's efforts to help maintain and improve the reliability of North America's bulk power system. NERC provides a number of additional programs and services designed to support owners, operators, and users of the bulk power system in their efforts to attain operational excellence. These include identifying issues before they have a chance to become critical, sharing best practices, supporting training and education, monitoring the international electric grid, and benchmarking performance to provide the industry with an objective lens through which to view itself.

Figure 1.1: NERC Regions

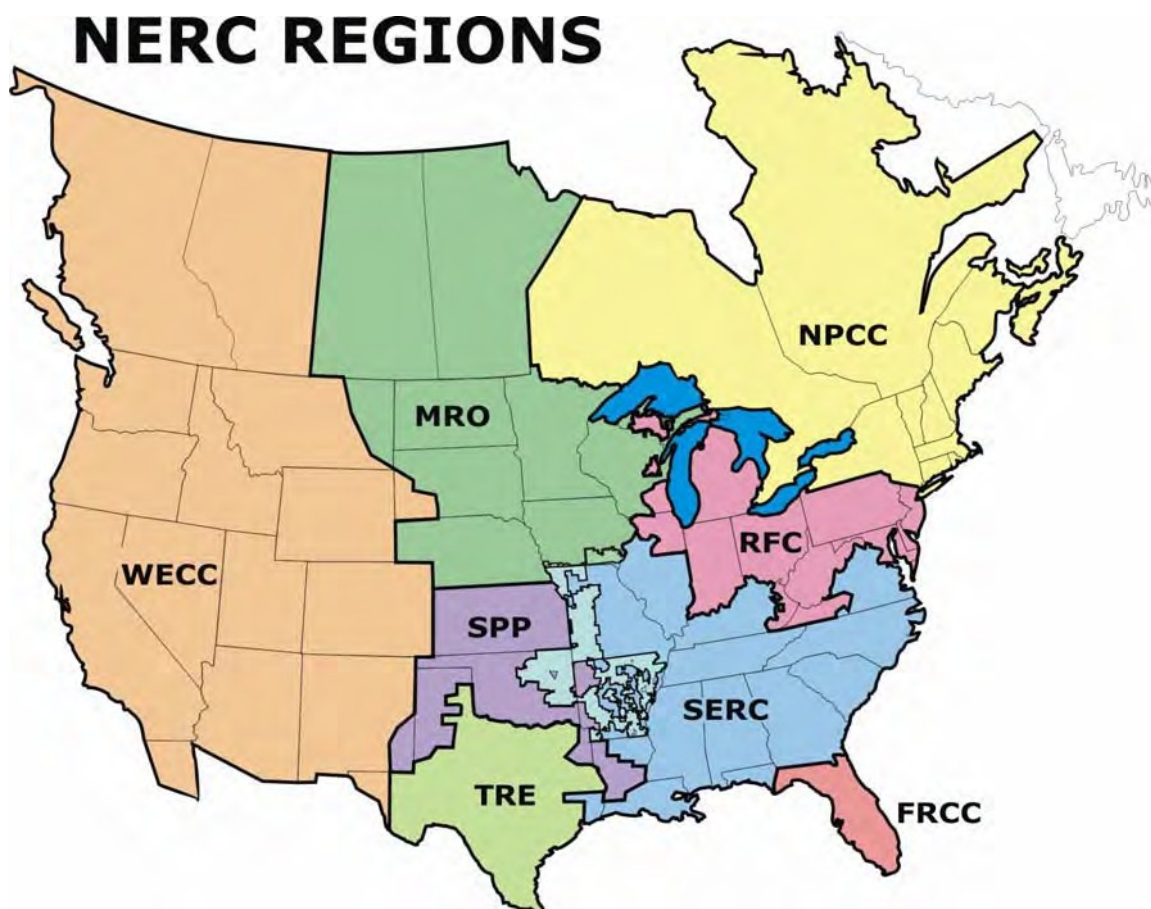

WECC members include investor-owned utilities, municipal utilities, public power systems, state, provincial, and federal agencies, non-utility generating companies, power marketers, and end users. Since committee representatives from your organization develop WECC standards, policies, and guidelines; you are really WECC. A current list of WECC members can be found on the WECC Web site <http://www.wecc.biz/>.

Membership in WECC is voluntary and consists of five classes of members as described below:

- Class 1. Electric Line of Business Entities owning, controlling or operating more than 1000 circuit miles of transmission lines of 115 kV and higher voltages within the Western Interconnection.
- Class 2. Electric Line of Business Entities owning, controlling or operating transmission or distribution lines, but not more than 1,000 circuit miles of transmission lines of 115 kV or greater, within the Western Interconnection.

- Class 3. Electric Line of Business Entities doing business in the Western Interconnection that do not own, control or operate transmission or distribution lines in the Western Interconnection, including power marketers, independent power producers, load serving entities, any other Entities whose primary business is the provision of energy services, and those Entities that are not eligible for membership in the other Member Classes and who have a substantial interest in the purposes of WECC.
- Class 4. End users of significant amounts of electricity in the Western Interconnection, including industrial, agricultural, commercial and retail entities as well as organizations in the Western Interconnection that represent the interests of a substantial number of end users or a substantial number of persons interested in the impacts of electric systems on the public or the environment.
- Class 5. Representatives of states and provinces in the Western Interconnection, provided that such representatives will have policy or regulatory roles and do not represent state or provincial agencies and departments whose function involves significant direct participation in the market as end users or in Electric Line of Business activities.

A nine-member independent Board of Directors (Board) elected by the WECC members governs WECC. A Member Advisory Committee (MAC) advises the board on any matters the Board requests the committee to evaluate or consider; and advise the Board on matters as the committee deems appropriate.

Three WECC standing committees have the responsibility to advise and make recommendations to the Board. The three WECC committees are:

- Operating Committee (OC)
- Planning Coordination Committee (PCC)
- Market Interface Committee (MIC)

An organization chart showing the reporting relationship of the various committees, subcommittees, and work groups is available on the WECC Web site.

Day-to-day activities of system operators, schedulers, and other operating personnel are closely related to one of the Operating Committee's subcommittees:

- Operations Training Subcommittee (OTS)
- Operating Practices and Event Analysis Subcommittee (OPEAS)
- Critical Infrastructure and Information Management Subcommittee (CIIMS)
- Interchange Scheduling and Accounting Subcommittee (ISAS)
- Remedial Action Scheme Reliability Subcommittee (RASRS)
- Technical Operations Subcommittee (TOS)
- Unscheduled Flow Administrative Subcommittee (UFAS)

With the advent of mandatory compliance with NERC Reliability Standards and WECC Regional Reliability Standards, WECC now has a Compliance division which also closely relates to the day-to-day activities of system operators, schedulers, and other operating personnel. This used to be monitored by the Compliance Monitoring and Operating Practices Subcommittee (CMOPS), which has been dissolved since the creation of the WECC Compliance division.

The WECC technical staff conducts studies, maintains databases, publishes reports, coordinates committee activities, and conducts operations-related training. The WECC staff does not make policy; it carries out policy. Many of these policies affect your work. More information about the WECC staff is available on the WECC Web site.

WECC members participate in WECC activities through the standing committees, subcommittees, and work groups. You can influence WECC decisions, national and regional standards, and policies by working with your company representatives on WECC committees.

## Section 1-3: WECC's Electrical System

WECC covers an area of nearly 1.8 million square miles. It is geographically the largest and most diverse NERC region. Its service territory extends from northern Alberta and British Columbia, Canada; through all or part of 14 western states; to the northern part of Baja California, Mexico.

For data reporting purposes, the region is divided into four major areas, called power areas or load areas. Transmission lines span the hundreds of miles between the hydro-electric resources of the Northwest, the coal-fired generation of the Rockies and Southwest, and the nuclear plants in the Northwest and the Southwest.

The four WECC areas are:

- Northwest Power Pool (NWPP)
- Rocky Mountain Power (RMPA)
- Arizona-New Mexico-Southern Nevada Power (AZ/NM/SNV)
- California-Mexico Power (CA/MX)

Figure 1.2 shows the WECC region and its four power areas.

The relative amounts of generation, transmission, and peak loads in WECC are available in information summaries posted on the WECC Web site.

**Figure 1.2: WECC Power Areas**



## Section 1-4: Reliability Coordination

Competition in the Electric Power Industry gave rise to the concern that deregulation and open access to the transmission system could potentially degrade the reliable operation of the grid. Market forces increase the pressure for maximized transmission utilization and economic efficiency, but political realities make system maintenance and expansion more difficult. In addition, a common conclusion reached in the aftermath of system disturbances was that no single entity had access to the “big picture” of the interconnection and that this lack hampered restoration efforts. In January 1996, the NERC Security Process Task Force published recommendations to increase the security of the system. One of the recommendations was to create a regional security plan and to establish security coordination centers in each NERC region. The WSCC Security Process Task Force was formed to implement the NERC recommendation and to develop the WSCC plan. This Task Force later became the WSCC Security Coordination Subcommittee and then in early 2002, was renamed as the WECC Reliability Coordination Subcommittee.

WECC provided the Reliability Coordination function for more than 10 years. WECC monitored the Bulk Electric System and provided real-time oversight to the entire Western Interconnection. The FERC Mandatory Standards give reliability coordinators the responsibility and authority to issue directives to electric system operators to protect system reliability.

As part of a strategic initiative adopted by the WECC Board in 2006, the WECC Reliability Coordination Offices (RCO) were consolidated from three to two, one in Vancouver, WA and the other in Loveland, CO. The new centers housed teams of RCs, study engineers, energy management system (EMS) support staff, and IT technicians. The RCOs operated with a single EMS — the West-wide System Model — and a common set of tools and training.

Both RC Offices were owned and operated by WECC, and became fully operational at the beginning of 2009. WECC’s objectives for this consolidation were to enhance EMS situational awareness and the reliability of the Western Interconnection in a cost-effective manner.

In 2012 the WECC Board began the process of bifurcating the RC function into an independent company in order to allow WECC compliance to audit and review RC operations in the Western Interconnection. In early 2014 WECC officially bifurcated from the new RC entity named Peak Reliability. Peak Reliability is now responsible for the reliable operation of the Western Interconnection in accordance with WECC and NERC standards.

Peak Reliability's mission is to view the overall operation of the interconnection, and to anticipate and mitigate potential systems problems, facilitate notifications, and coordinate restoration following a system emergency. The Reliability Coordinator offices in Vancouver, WA and Loveland, CO are responsible for monitoring system conditions in their areas in real time. They observe, study, and mitigate potential problems as well as respond to system emergencies.

Peak Reliability maintains a website at [www.PeakRC.org](http://www.PeakRC.org)

This page intentionally left blank



**Module 2:  
Fundamentals of Electricity**



## Module 2: Fundamentals of Electricity

### Table of Contents

<b>Fundamentals of Electricity .....</b>	<b>2-5</b>
<b>Section 2-1: Review of Direct Current .....</b>	<b>2-5</b>
Electrical Quantities and Circuit Elements .....	2-5
Charge .....	2-7
Current .....	2-8
Voltage .....	2-8
Resistance .....	2-10
Power .....	2-12
Magnetism and Electromagnetism .....	2-12
Inductance .....	2-16
Capacitance .....	2-16
Circuit Laws .....	2-16
Ohm's Law .....	2-17
Kirchhoff's Law .....	2-18
<b>Section 2-2: Alternating Current .....</b>	<b>2-19</b>
Sine Waves .....	2-19
Phase Relations .....	2-21
Resistance in AC Circuits .....	2-22
Inductive Reactance in AC Circuits .....	2-23
Capacitive Reactance in AC Circuits .....	2-24
<b>Section 2-3: Power in AC Circuits.....</b>	<b>2-26</b>
Phasor Diagrams .....	2-26
Power in Resistive Circuits .....	2-27
Power in Reactive AC Circuits .....	2-27
Right Triangle Relationships .....	2-28
Power Triangle .....	2-29
<b>Section 2-4: Three-Phase Circuits .....</b>	<b>2-33</b>
Three-Phase Connections .....	2-34
<b>Section 2-5: Electromechanics .....</b>	<b>2-36</b>
<b>Module 2: Fundamentals of Electricity Question Set.....</b>	<b>2-37</b>

## Module 2: Fundamentals of Electricity

### Table of Figures

Figure 2.1: Simplified Battery .....	2-9
Figure 2.2: Series and Parallel Resistors .....	2-11
Figure 2.3: Magnetic Field of a Magnet.....	2-13
Figure 2.4: Current-Carrying Conductor.....	2-14
Figure 2.5: Coil .....	2-14
Figure 2.6: Induced Voltage .....	2-15
Figure 2.7: Sine Waves.....	2-19
Figure 2.8: Phase Angle .....	2-21
Figure 2.9: Inductive Circuit .....	2-24
Figure 2.10 Capacitive Circuit.....	2-25
Figure 2.11: Phasor Diagram .....	2-26
Figure 2.12: Right Triangle. ....	2-28
Figure 2.13: Power Triangle.....	2-32
Figure 2.14: Three-Phase Generator .....	2-34
Figure 2.15: Delta Connection .....	2-34
Figure 2.16: Wye Connection .....	2-35

This page intentionally left blank.

## Fundamentals of Electricity

### Module Overview

The **Fundamentals of Electricity** module presents the following topics:

- Review of Direct Current
- Alternating Current
- Power in AC Circuits
- Three-Phase Power
- Electromechanics

#### Definition: Electricity

**Electricity** is the science dealing with electric charges and currents. We begin our study of electricity by reviewing direct current.

### Section 2-1: Review of Direct Current

In this section, we review the basic circuit concepts needed to understand electricity. We will examine the following topics:

- Electrical Quantities and Circuit Elements
- Circuit Laws

### Electrical Quantities and Circuit Elements

**Electron Theory** is the basis for all concepts about electrical properties. Electron Theory states:

Atoms constitute all matter.

Matter is anything that has weight and occupies space.

- Atoms contain:

- A nucleus, which contains neutrons and protons.
- Electrons that orbit around the nucleus.
- Protons carry a positive charge, neutrons have no electrical charge, and electrons carry a negative charge.
- Since neutrons have no charge, they have no electrical effect on the atom. Normally, the number of positively charged particles equals the number of negatively charged particles, so the atom is electrically neutral.
- Electrically charged particles exert forces upon each other.
- Two charged particles that have the same charge (both positive or both negative) repel each other.
  - For example, two negatively charged electrons repel each other.
  - Conversely, two charged particles that have different charges (one positive and one negative) attract each other.

**Definition: Electric Field**

A group of one or more similarly charge particles create an **electric field**. The field's intensity depends on the distance from the charged particles.

As the distance increases, the electric field decreases.

Two groups of particles with opposite charges create an electric field between them.

The further the negatively charged electrons are from the positively charged nucleus the weaker the bond between them. This is because the electrons closer to the nucleus have a stringer attraction to the protons in the nucleus. However, the electrons further from the nucleus have a weaker attraction to the protons in the nucleus.

**Definition: Free Electrons**

In some matter such as copper, the bond is so weak that the electrons jump from one atom to another. These loosely-bound electrons are called **free electrons**.

In general there are two types of material:

- Conductors
- Insulators

**Definition: Conductor**

A **conductor** is a material that has a large number of free electrons that continually jump to other atoms. By jumping from atom to atom, the electrons travel very easily through a conductor.

Good electrical conductors are copper and aluminum. Gold, silver, and platinum are also good conductors, but are very expensive.

**Definition: Insulator**

An **insulator** is a material that has only a few free electrons. In insulators, the electrons are tightly bound by the nucleus. Therefore, the electrons do not travel easily through an insulator.

Good electrical insulators are rubber, porcelain, glass, and dry wood.

**Charge****Definition: Coulomb (Q)**

We know all electrons carry a negative electrical charge. But, we have not defined the base unit of charge. The unit of one electron or proton is too small to be the base charge unit. Instead, the unit of charge is the coulomb with a unit symbol Q.

A charge of an electron is  $-1.6 \times 10^{-19}$  Q and the charge of a proton is  $1.6 \times 10^{-19}$  Q.

$$-1.6 \times 10^{-19} \text{ Q} = 1 \text{ electron}$$

$$1 \text{ Q} = \frac{1}{-1.6 \times 10^{-19}} \text{ electron}$$

Therefore, it takes  $6.25 \times 10^{19}$  electrons to make up one Q of charge.

## ***Current***

### **Definition: Current (I)**

Electric current results from moving charged particles in a specified direction. **Current** flow is the rate of electron flow. We measure it in amperes with a unit symbol A.

One ampere of current results from one coulomb of charge passing a given point in a conductor in one second.

### **Definition: Direct Current (DC)**

Current is the flow of electrons. The direction of the current is the direction of the electron flow. By convention, the direction of current flow is in the direction of positive charge movement and against the direction of negative charge movement. Positive charge movement is in the opposite direction from electron movement. In this training manual, the current direction is based on the direction of electron flow. Current that flows in only one direction is called **direct current** and is abbreviated DC. This is the type of current we get from flashlight cells and batteries. Other users of DC are an excitation system for a generator, DC motors, and some control circuits.

### **Definition: Alternating Current (AC)**

**Alternating Current**, abbreviated AC, is current that flows in one direction then flows in the opposite direction. AC continuously changes in magnitude and direction. AC is the type of current we use in the sockets and electrical boxes in our homes. We discuss AC in detail later in this module.

## ***Voltage***

### **Definition: Voltage (V)**

**Voltage** is the force that causes electrons to move. Voltage is also referred to as potential difference or electromotive force (abbreviated emf or E). All the terms mean the same thing: the force that sets charges in motion. The symbol for voltage is V and the unit of measurement is volts.

At the beginning of this section, we stated that free electrons jump from one atom and attach themselves to another atom. Normally this occurs in a random or unsystematic pattern. For there to be organization to the flow of electrons, there must exist a difference in potential.

If we attach a battery or a generator to the ends of a conductor, a potential force causes loosely held electrons to flow in an organized manner. This is current. What makes this occur? Let's examine what happens in a battery.

**Figure 2.1: Simplified Battery**

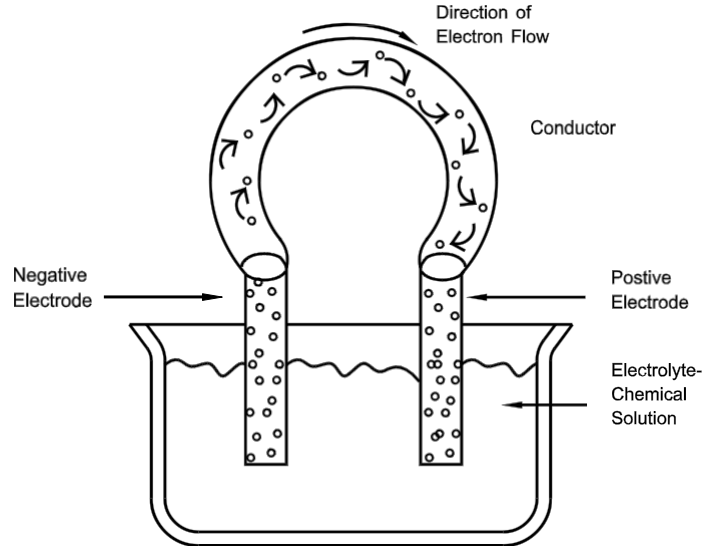

In the battery, two different metals, called **electrodes**, are placed in a chemical solution called the **electrolyte**. The electrolyte reacts oppositely with the two different electrodes.

- The electrolyte causes one electrode to lose electrons and develop a positive charge.
- The electrolyte causes the other electrode to gain electrons and develop a negative charge.

This results in a difference in potential between the two electrodes. So, when we attach the ends of a conductor to the electrodes of the battery, the difference in potential causes the loosely held electrons to flow from the negative electrode to the positive electrode.

Voltage is the difference in potential between two points, such as the electrodes on the battery. We can create voltage by a number of methods. All involve the conversion of some other form of energy into electric energy.

- Electric generators convert mechanical energy into electrical energy.
- Battery cells convert chemical energy into electrical energy.
- Solar cells produce voltage by converting the energy in light.
- Thermocouples produce voltage by heating dissimilar metals held in close contact.

## ***Resistance***

### **Definition: Resistance (R)**

**Resistance** is the property of materials that opposes or resists current by converting electric energy to heat. The symbol for resistance is R. It is measured in ohms ( $\Omega$ ).

All materials present some resistance to current flow, some more than others. We know that electrons move very easily in conductors. This is because they have a lower resistance than insulators.

You may recall from reading earlier in this section that conductors have a large number of free electrons so they readily allow current to flow. Insulators have only a few free electrons, so they obstruct current flow.

In reality, all material resists current flow to some extent. Conductors resist less than insulators and some conductors resist less than other conductors.

The amount of resistance for a particular material depends on the following parameters:

- Material's length
  - Decreasing the material's length decreases the resistance.
- Material's cross-sectional area
  - Increasing the material's cross-sectional area decreases the resistance.

Resistance is also dependent upon conductor temperature. The hotter the wire, the more resistance it exhibits.

Resistors can be connected in series or in parallel, as shown in Figure 2.2.

Figure 2.2: Series and Parallel Resistors

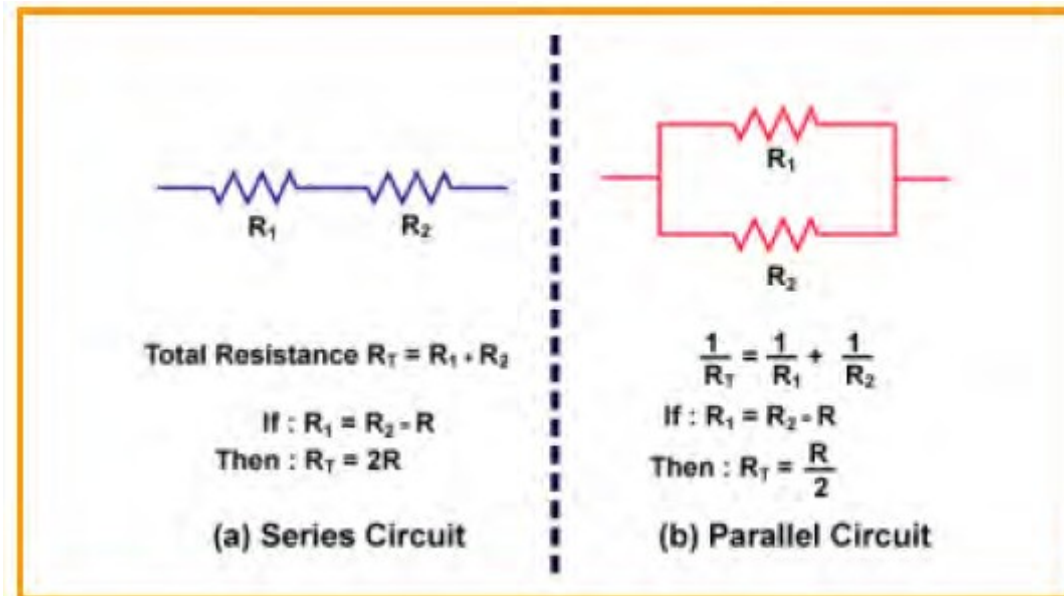

A series circuit contains two or more resistors. But it only has one path on which the current can flow from the source through the resistors and back to the source.

To determine the total resistance, called **equivalent resistance**, in the series circuit for resistors in service, we use the following formula:

$$R_{eq} = R_1 + R_2$$

We can replace the resistors in the circuit with a single resistor,  $R_{eq}$ , without changing the properties of the circuit.

A parallel circuit contains two or more resistors. There is more than one current path from the source through the resistors and back to the source. Figure 2.2 indicates the different current paths  $I_1$  and  $I_2$ .

To determine the total resistance in the parallel path circuit, again called the **equivalent resistance**, we use the following formula:

$$\frac{1}{R_{eq}} = \frac{1}{R_1} + \frac{1}{R_2} + \frac{1}{R_3} \quad \text{or} \quad R_{eq} = \frac{1}{\frac{1}{R_1} + \frac{1}{R_2} + \frac{1}{R_3}}$$

It is important to realize that, when there are two or more parallel paths, more current flows through the path of least resistance than through any other path. This is important when there are parallel lines that are not equal in length or resistance.

**Note:** *Circuit elements other than resistors can be combined in series and parallel. Parallel connections are sometimes called shunt connections.*

## ***Power***

### **Definition: Power (P)**

**Power** is the rate at which work is performed. Electricity's ability to perform work is measured in watts. Electric power is calculated by multiplying the potential difference (volts) times the current flow (amps).

$$\text{Power} = \text{Voltage} \times \text{Current}$$

For example:

If a conductor is subjected to a 16-volt difference in potential and allows 10 amps of current to flow, how much power does it consume?

Using the formula for power and substituting the known values, we have:

$$P = VI$$

$$P = (16V)(10A)$$

$$P = 160 \text{ Watts}$$

We discuss power in more detail later in this module.

## ***Magnetism and Electromagnetism***

Wherever an electric current exists, a magnetic field also exists. Therefore, to understand electricity we must understand magnetism and how it is produced.

Magnetism is an invisible force field that acts on all materials in varying degrees. Magnets have this invisible force. Because of this force, magnets attract iron and steel.

### **Definition: Magnetic Field**

The ***magnetic field*** is the invisible force of magnetism. Figure 2.3 shows a magnet's magnetic field.

**Figure 2.3: Magnetic Field of a Magnet**

Figure 2.3 illustrates the following phenomenon:

- Outside the magnet, the lines of force extend in continuous lines from the north pole to the south pole.
- Inside the magnet, the lines of force extend in continuous lines from the south pole to the north pole.
- The concentration of the force lines is called the **magnetic flux**, which is the number of force lines per unit of cross-sectional area.
  - Where the lines of flux are dense, the magnetic field is strong.
  - Where the lines of flux are sparse, the magnetic field is weak.
- The magnetic flux is most dense at the magnet's ends, so this is where the magnetic field is strongest. The magnetic field gets weaker as the distance from the magnet increases.

Electric current creates magnetic fields. Figure 2.4 shows a current-carrying conductor.

**Figure 2.4: Current-Carrying Conductor**

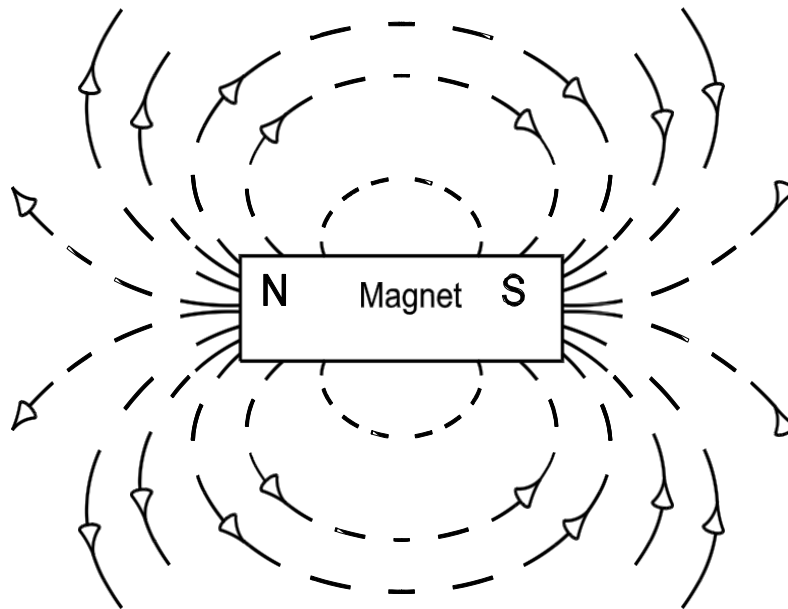
Figure 2.4 shows the magnetic field around a conductor. Although the **flux** is shown in only three places, it actually is a continuous field along the entire conductor's length. If the current's direction is reversed, the lines of force reverse direction.

The magnetic field's strength, **the flux**, is determined by the amount of current flowing through the conductor. The flux is weak around a single conductor. However, we can increase the flux by combining the fields around two or more conductors. We do this by bending a conductor. The conductor is now called a **coil**.

**Figure 2.5: Coil**

Figure 2.5 shows the coil's magnetic field. You can see that minimizing the separation between the coil's windings, causes the flux of the individual turns to combine to produce one stronger magnetic field.

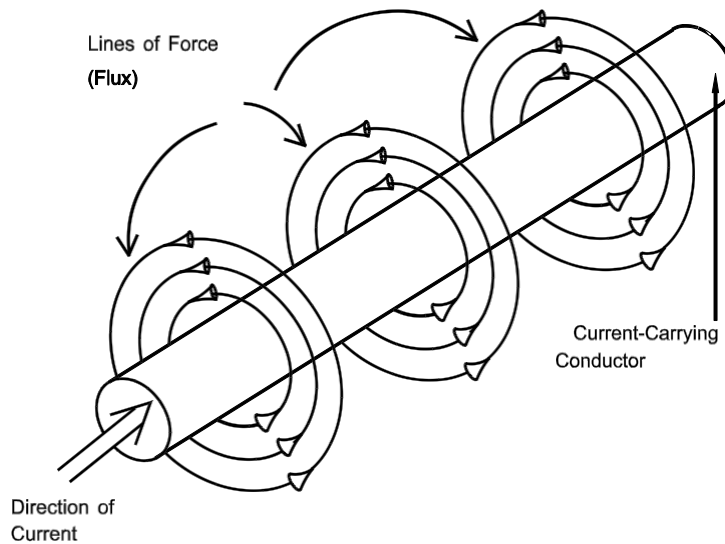
We know that a current-carrying conductor produces a magnetic field. Now we will see that magnetic field can induce voltage in a conductor.

**Figure 2.6: Induced Voltage**

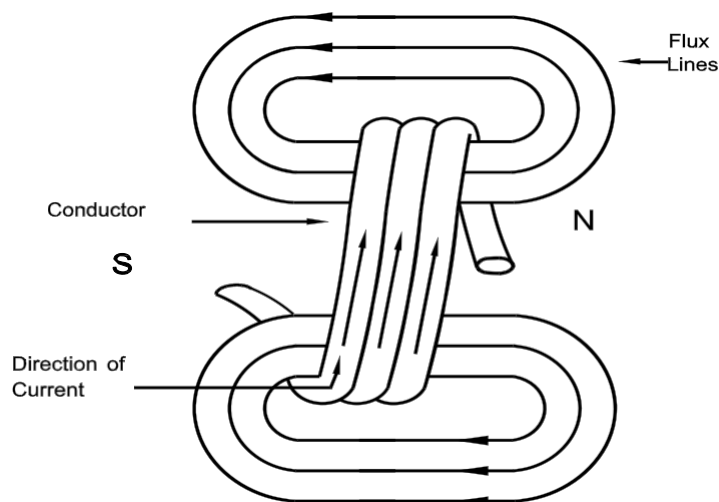
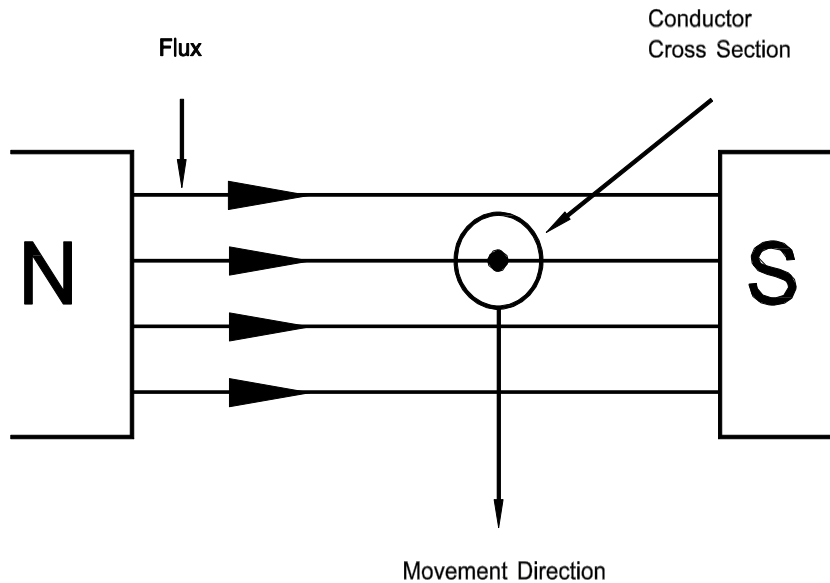

Figure 2.6 illustrates the following:

- Moving a conductor perpendicularly across lines of magnetic flux induces a voltage in the conductor.
- The amount of voltage depends upon the amount of flux and the speed of the movement.
  - The greater the flux and speed, the greater the voltage.
- If the conductor moves toward either of the magnetic poles (left or right, instead of up and down), a voltage is not induced.

### **Definition: Electromagnetic Induction**

Induced voltage, commonly called **electromagnetic induction**, is the principle used to operate electric generators and transformers.

What we describe earlier as a coil is commonly called an inductor. It exhibits a property called inductance.

## ***Inductance***

### **Definition: Inductance (L)**

***Inductance*** is the property of an electrical circuit that opposes change in current. The symbol used to represent inductance is L and the unit of inductance is the Henry (H).

Any component that we use for its inductive property is called an ***inductor***. An inductor also is commonly called a ***reactor***.

A circuit's inductance depends on:

- number of turns in the coil
- coil's shape
- coil's diameter
- material coil is wound on

We examine inductance in more detail later in this module. Now let's briefly look at another property of electrical circuits, capacitance.

## ***Capacitance***

### **Definition: Capacitance (C)**

***Capacitance*** is the property of an electrical circuit that opposes change to voltage by using energy stored in an electric field. The symbol we use to represent capacitance is C and the unit of capacitance is the farad (F). Any component that we use for its capacitance property is called a ***capacitor***.

We examine capacitance in more detail later in this module.

## ***Circuit Laws***

To aid in studying the effect of the various circuit elements on the power system, we accept that certain relationships exist. These include:

- Ohm's Law
- Kirchhoff's Laws

We briefly describe these laws in the next few pages.

## Ohm's Law

### Definition Ohm's Law

From our battery example, we know that a difference (voltage) causes electric current to flow in a conductor. We also know that a conductor has some resistance to flow (but less resistance than an insulator). The current is proportional to the applied voltage. This relationship is known as **Ohm's Law**, and it states:

- Given a potential difference of one volt and a conductor with one ohm resistance, the intensity of the current flow is one ampere.
- Ohm's Law is:

$$I = \frac{V}{R}$$

Where

- I = Current (amperes)
- V = Voltage drop or potential difference (volts)
- R = Resistance (ohms)

If the resistance remains constant, an increase in voltage increases the current flow. What happens if the resistance changes?

For example, if we attach a difference of 12 volts to a conductor that possesses 2 ohms of resistance, we can determine the resulting current flow by using Ohm's Law:

$$I = \frac{V}{R}$$

Substituting the known values into the equation and solving for I we have:

$$I = \frac{12 \text{ Volts}}{2 \text{ ohms}}$$

$$I = 6 \text{ amperes}$$

Or

$$I = 6 \text{ A}$$

If we replace the 2 ohm resistance conductor with a conductor having 4 ohms of resistance, we create the resulting change in current flow:

$$I = 3 \text{ A}$$

So we see that, if the voltage remains constant, the current flow decreases as resistance increases.

Kirchhoff's Laws are a set of laws that also provide us with a method of solving for unknown parameters in a circuit.

### ***Kirchhoff's Law***

We can use two Kirchhoff's Laws to determine unknown circuit parameters:

- Kirchhoff's Current Law
- Kirchhoff's Voltage Law

#### **Definition: Kirchhoff's Law**

***Kirchhoff's Current Law*** states that the sum of the currents entering a junction equals the sum of the currents leaving a junction.

- For series circuits, this means that the current is the same at all points.
- For parallel circuits, this means that the total current in a parallel circuit is equal to the sum of the currents in each branch.

#### **Kirchhoff's Voltage Law**

The voltage difference across a resistor is called a voltage drop.

- In series circuits, the sum of the voltage drops around the circuit is equal to the applied voltage.
- In parallel circuits, the voltage drops across all the branches are the same.

Until now, we have been examining direct current. However, almost all electric power generated by utilities is supplied as alternating current (AC). Let's examine some of the characteristics of AC.

## Section 2-2: Alternating Current

### Definition: Alternating Current

**Alternating current (AC)** is a current that periodically changes its direction of flow and its magnitude. If there is AC, there also must be an alternating voltage and AC power.

- AC voltage is the voltage that produces an alternating current.
- AC power is the power produced by alternating current and alternating voltage.

We explain earlier in this module that the current and the voltage change direction and magnitude. The magnitude and direction can be represented by a line on a graph. The waveform of AC is called a sine wave. Let's examine the sine wave in more detail.

### Sine Waves

#### Definition: Sine Waves

A **sine wave** has a very specific shape, as shown below in Figure 2.7, and is described using a number of terms as defined below.

Figure 2.7: Sine Waves

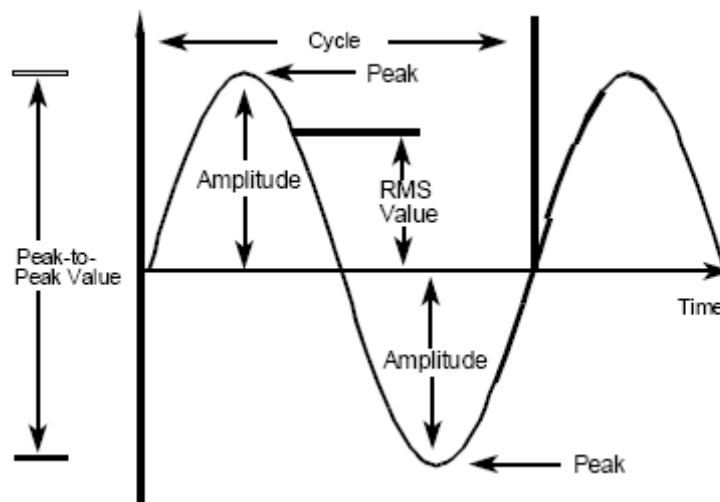

**Definition: Cycle**

The waveform in Figure 2.7 illustrates the following terms:

A cycle is the part of a waveform that does not repeat or duplicate itself. For the current waveform shown in Figure 2.7, in the time it takes to complete one cycle, the current:

- builds from zero to the maximum amplitude in one direction
- decays back to zero
- builds to the maximum amplitude in the opposite direction
- decays back to zero again

**Definition: Period (T) and Frequency (f)**

- The period (T) is the time required to complete one cycle.
- Frequency (f) is the rate at which the cycles are produced. In other words, frequency is how rapidly the current or voltage changes polarity.
- Frequency is measured in hertz (Hz). One hertz equals one cycle per second. Frequency (f) and period (T) are related by the following equation:

$$T = \frac{1}{f} \quad f = \frac{1}{T}$$

**NOTE:** For power systems in North America, the frequency is operated at 60 Hz. So the cycle is repeated 60 times each second.

**Definition: Amplitude/Peak/Peak-to-Peak/Effective Value**

The **amplitude** is the value of the current at a specific time. The amplitude can be specified in several ways:

The **peak** value is the waveform's maximum value. For a sine wave, the peak occurs twice: once in the positive half of the cycle and once in the negative half of the cycle.

The **peak-to-peak** value is equal to twice the peak value.

The **effective** or **root mean square** value of alternating current is the amount of alternating current that has the same effect as a given amount of direct current in producing heat in a resistive circuit. Effective value is the most common way of specifying the amount of AC.

One ampere of effective AC and one ampere of DC produce the same power when flowing through equal valued resistors.

### Definition: Root Mean Square (RMS) Value

We can determine the effective value of a waveform mathematically by a process called **root mean square (rms)**. Squaring the instantaneous values over one period, averaging the values to provide the mean, and taking the square root of the mean provides the rms value.

The following relationship exists between the sinusoidal peak value ( $I_p$ ) and the rms ( $I_{rms}$  value):

$$I_{rms} = .707I_p$$

We can mark the horizontal axis of the waveform in degrees or units of time.

- The positive portion of the cycle contains  $180^\circ$ .
- The negative portion of the cycle contains  $180^\circ$ .
- Each half-cycle is 8.33 milliseconds (.00833 seconds) when the frequency is 60 Hz.

## Phase Relations

### Definition: Phase Angle

Sine waves with the same frequency have what is called phase relations. A phase relation, sometimes called **phase angle**, is the angular difference between sine waves. Phase angle is the portion of a cycle that has elapsed since another wave passed through a given value.

Figure 2.8 shows the phase angle difference between two voltages –  $V_1$  and  $V_2$ .

Figure 2.8: Phase Angle

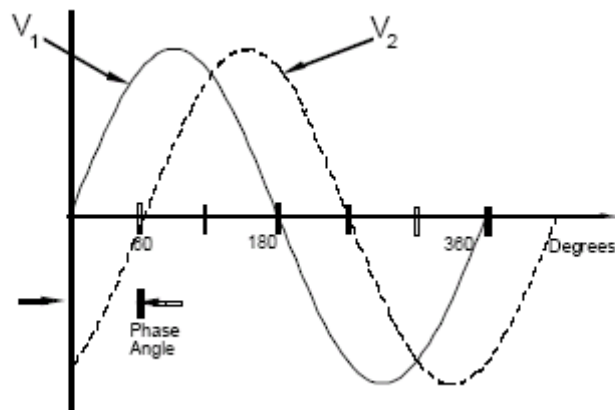

In Figure 2.8, since  $60^\circ$  is added to  $V_1$ , the following statements can be made:

- $V_1$  leads  $V_2$  by  $60^\circ$ .
- $V_2$  lags  $V_1$  by  $60^\circ$ .

Another way to describe the phase relation is to say that  $V_1$  and  $V_2$  have a  $60^\circ$  phase difference or that they are  $60^\circ$  out of phase with each other.

Phase difference compares current with current, voltage with voltage, or a current with a voltage.

### **Definition: In-Phase**

**In-phase** means the phase difference between the two variables is zero degrees. On a phase angle diagram, such as Figure 2.8, this means the two variables cross the zero magnitude level at exactly the same time.

### **Definition: Out-of-Phase**

**Out-of-phase** means that the phase difference between the two variables is not zero degrees. This means the two variables cross the zero magnitude level at different times.

Phase difference is a concept that applies only to two waveforms that have the same frequency. If the frequency is different, the phase-angle difference constantly changes.

Earlier in this module we introduce the resistor, inductor, and capacitor; and we discuss Ohm's and Kirchhoff's Laws. We can use Ohm's and Kirchhoff's Laws to solve AC circuits as well as DC. Let's examine how.

## **Resistance in AC Circuits**

We know that the following equation can be used to find the voltage in a resistive circuit:

$$V = IR$$

Since this equation does not depend upon frequency, we can see that the current through a resistor and the voltage drop across the resistor are always in phase.

- The voltage and current cycles begin and end at the same time.
- The peak values occur at the same time.

What happens in a circuit with inductance?

## Inductive Reactance in AC Circuits

### Definition: Inductive Reactance

In an AC circuit, the opposition that inductance provides to alternating current is called **inductive reactance**. The symbol for reactance is  $X$ . Inductors are not the only components that have reactance, so we use a subscript to indicate that the reactance is inductive ( $X_L$ ).

Similar to resistance, reactance controls the amount of current in a circuit. The unit for reactance is also the ohm ( $\Omega$ ). However, unlike resistance, reactance does not convert the electrical energy into heat energy. Therefore we cannot interchange the terms resistance and reactance.

Inductive reactance is the result of the voltage induced in the coil by the moving magnetic field created by the current flow. The inductor allows just enough alternating current flow to produce a voltage equal and opposite to the source voltage.

The following form of Ohm's Law applies to inductive reactance:

$$V_{\text{eff}} = I_{\text{eff}}X_L \text{ and } X_L = 2\pi fL$$

Where

$V_{\text{eff}}$  and  $I_{\text{eff}}$  = Effective values for voltage and current, respectively.

$\pi$  = Constant (approximately 3.14)

$f$  = Frequency

$L$  = Inductance

We can see from the second equation that inductive reactance depends on frequency.

Increasing the frequency increases the inductive reactance.

This makes sense because the higher the frequency, the more rapidly the current is changing. Therefore, more induced voltage and reactance are produced.

So what is the relationship between the current and the voltage in an inductive circuit?

**Figure 2.9: Inductive Circuit**

Figure 2.9 shows the waveforms of both voltage and current.

From Figure 2.9 we see that, in an inductive circuit with zero resistance, the current lags the voltage by  $90^\circ$ . This occurs because the inductance retards the current wave and causes it to lag behind the voltage wave.

The maximum amount that the inductance can cause the current to lag behind the voltage is  $90^\circ$ .

Now let's examine another circuit component that has reactance – the capacitor.

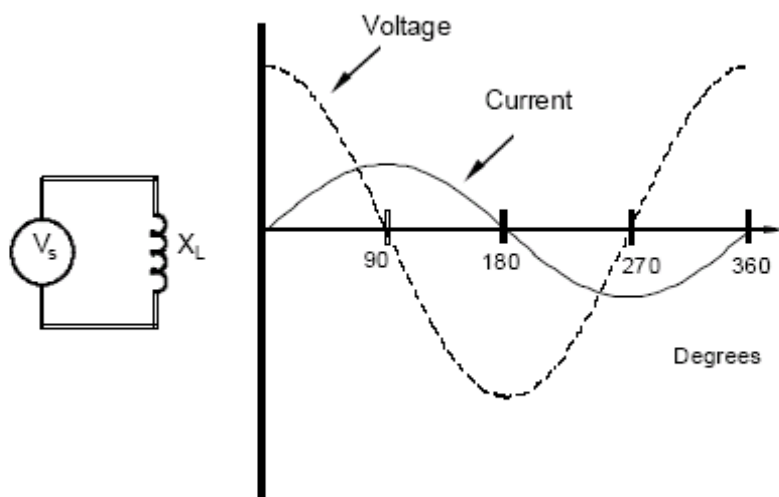
## Capacitive Reactance in AC Circuits

A capacitor controls the current in an AC circuit by storing energy that produces a voltage in the capacitor. The voltage produced is always in opposition to the source voltage.

Similar to inductance, capacitance controls current without converting electrical energy into heat energy. Therefore, its opposition is also called reactance.

**Capacitive reactance** uses the symbol  $X_C$ . Applying Ohm's Law to a capacitive circuit, we have:

$$I = \frac{V}{X_C} \quad X_C = \frac{1}{2\pi fC}$$

Again, similar to inductive reactance, we see from the equation that capacitive reactance depends upon frequency. However, a different relationship exists:

Increasing the frequency decreases the capacitive reactance.

**Definition: Susceptance**

There are times when using the reciprocal of  $X_C$  makes calculations easier. The reciprocal of  $X_C$  is  $B_C$  and is called **susceptance**. So now:

$$I = VB_C$$

What is the relationship between the current and voltage in a capacitive circuit?

Figure 2.10 shows the waveforms of each.

**Figure 2.10 Capacitive Circuit**

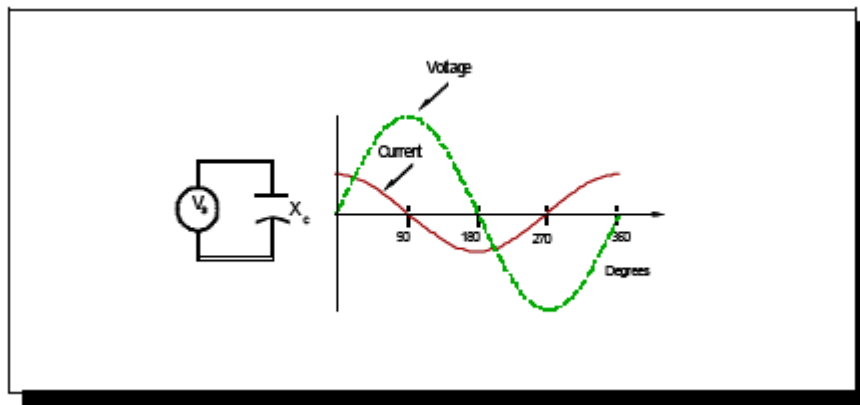

From Figure 2.10 we see that in a capacitive circuit with zero resistance, the current leads the voltage by  $90^\circ$ .

Now we are ready to examine power in AC circuits.

## Section 2-3: Power in AC Circuits

To understand phase relationships and their effect on power in AC circuits, we must first review phasor diagrams.

### Phasor Diagrams

Definition: Phasor

In the previous section, we discussed sine waveforms and phase shift. Another way to show amplitude and phase shift is to use phasors. A **phasor** is a line for which:

- The length represents the electrical quantity's magnitude or value.
- The direction represents the phase angle (in electrical degrees).

The following conventions are used for phasors:

- Zero electrical degrees is on the right side of the horizontal axis.
- Rotation is in a counterclockwise direction.

Figure 2.11 shows a phasor diagram for a voltage and current.

Figure 2.11: Phasor Diagram

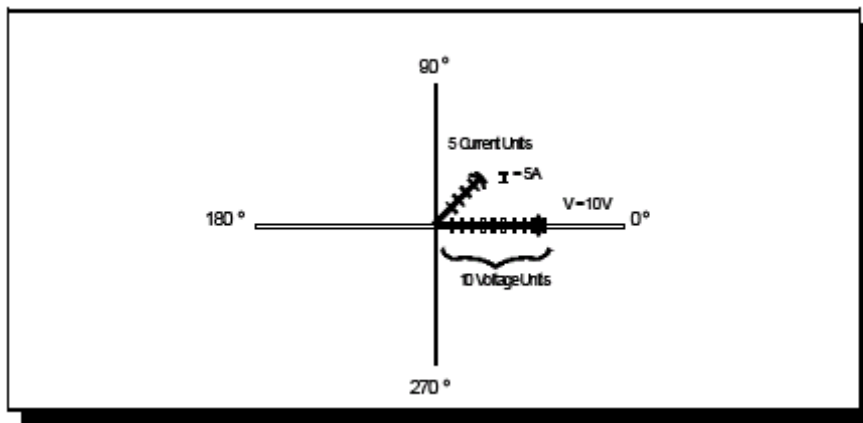

Since phasors rotate in a counterclockwise direction, Figure 2.11 shows the current leading the voltage by 45°.

**Definition: Phasor Sum**

Phasors can be added, subtracted, multiplied, and divided. A **phasor sum** is the addition of phasors. When adding phasors, the phasor is broken down into a horizontal and a vertical component. These two components can then be added.

**Power in Resistive Circuits**

Earlier in this module we state that power is the rate at which work is performed and is measured in watts. Power can also be thought of as the rate at which energy is used or dissipated.

In a resistive circuit, the current and voltage are in phase. That is, the two waveforms arrive at their peak values and zero values at the same time.

**Definition: Real Power**

The power consumed by the resistance in a circuit is called **real power** and is expressed in the units of watts. Real power is calculated using the following equation:

$$P = IV = I(IR) = I^2R$$

Or

$$P = \frac{W}{R} = \frac{V^2}{R}$$

**Definition: Losses**

**Losses** are the power dissipated as heat when power flows in transmission lines and transformers.

Either real power equation can be used to find the power dissipated in a resistor. The resistor converts the electrical energy into heat energy and real power losses occur due to  $I^2R$  heating.

Not all circuits are entirely resistive – they may contain reactance. Let's examine the power in reactive circuits.

**Power in Reactive AC Circuits**

Earlier in this module we describe the effect of inductive reactance and capacitive reactance on the voltage and current in a circuit. We know that reactance causes a phase shift to occur between the voltage and the current. If the circuit contains only

inductance or only capacitance, then a maximum  $90^\circ$  phase shift occurs between the voltage and the current.

However, most circuits combine resistance and reactance. This results in a phase shift of less than  $90^\circ$ . The exact amount of the phase shift is determined by the relative amount of resistance and reactance.

When there is a phase shift, calculating power becomes more complex. Unlike resistors, pure inductors and capacitors do not consume power, they store and release energy. Also, in a resistive circuit, the current and voltage are in phase. But that is not the case in a reactive circuit.

### Definition: Reactive Power

**Reactive power** is the power used to support the magnetic and electric fields found in inductive and capacitive loads throughout a power system. Reactive power is measured in volt amperes reactive (Vars).

So how do we calculate the power for a combination circuit? We need to break the current and voltage into resistive and reactive parts. We do this by using phasors and right triangle relationships.

We have described phasors, so let's briefly examine right triangle relationships.

## Right Triangle Relationships

Figure 2.12: Right Triangle.

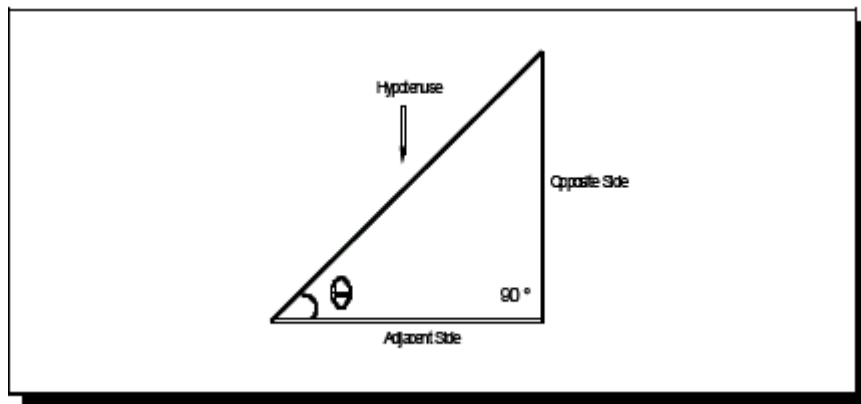

For the right triangle shown in Figure 2.12:

- The symbol  $\Theta$  represents the angle we use to analyze the triangle.
- The adjacent side is the leg of the triangle next to (below)  $\Theta$ .

- The opposite side is the leg of the triangle opposite  $\Theta$ .

The right triangle can be used to represent the resistive and reactive portions of the current and voltage.

If current phasors are being represented on a right triangle:

- The adjacent side is the resistive current phasor.
- The opposite side is the reactive current phasor.
- The hypotenuse is the total current phasor.
- The phase angle between the resistive current and the reactive current is equal to the angle between them.

### Definition: Impedance ( $Z$ )

The total opposition to current is called **impedance** and is the phasor sum of the resistance and reactance. Impedance is represented by a  $Z$  and measured in ohms ( $\Omega$ ).

Similarly, the right triangle can also be used to represent the resistive, reactive, and total voltage of a circuit as the adjacent side, opposite side, and hypotenuse of the triangle, respectively.

## Power Triangle

Another application of the right triangle is the power triangle. The general equation for power in all types of circuits is:

$$P = I V \cos \Theta$$

If a circuit contains only resistance, then  $\cos \Theta$  equals 1 and the equation agrees with the equation for real power — the power dissipated in a resistor. Remember: real power is the actual power used by the circuit.

### Definition: Apparent Power ( $P_{app}$ )

**Apparent power** ( $P_{app}$ ) is the power that appears to be present when the voltage and current in the circuit are measured separately. The apparent power is the product of the voltage and the current, regardless of the phase angle. We define it with the following equation:

$$P_{app} = IV$$

Apparent power is measured in volt-amperes (VA). (Real power is measured in watts.) If a circuit contains both resistance and reactance, the real power does not equal the apparent power.

**Definition: Power Factor (PF)**

If we look at the two equations (real power and apparent power) we see that they differ only in that the real power includes the  $\cos \Theta$ . The ratio of the real power and apparent power is called the **power factor** (PF). Power factor can be expressed as a percentage or a decimal number.

The equation for power factor ( $\cos \Theta$ ) is:

$$PF = \cos \theta = \frac{P}{P_{app}} = \frac{\text{Watts}}{\text{VA}}$$

Power factor indicates the portion of the total current and voltage that is producing real power. In other words, power factor indicates the amount of apparent power that is actually doing work.

- If the current and voltage are in phase, real power equals apparent power, and the resulting power factor is 1.
- If the current and voltage are  $90^\circ$  out of phase, the power factor is 0.
- The power factor can be any value between 0 and 1.

How does power factor affect the customers and the utility?

Utilities should maintain the power factor as close to one as possible, without compromising voltage or customer service.

- For the customer, a high power factor enables motors and other equipment to provide their rated power without drawing excess current that may cause damage to equipment.
- For the utility, electric energy transfer is more efficient with higher power factors. That is, the power system can transmit and distribute more real power without having to increase the current carrying capabilities of conductors, transformers, and other equipment. This ultimately saves money.

For example, suppose a utility sells energy to two different manufacturers. The two manufacturers are located equidistant from the substation.

- Both receive power at the same voltage (4700 V).
- Both require the same real power (2 MW).

However, Manufacturer A uses a lot of reactive loads (motors) and operates with a power factor of 60%. Manufacturer B uses mostly resistive loads (heaters) and operates with a power factor of 97%.

To serve Manufacturer A, the utility must provide the following volt-amperes.

$$P_{app} = \frac{P}{PF}$$
$$P_{app} = \frac{2,000,000}{.6}$$
$$P_{app} = 3,333,333.3$$
$$P_{app} = 3.3\text{MVA}$$

To serve this load, the utility's conductors must be able to carry the following current:

$$I = \frac{P_{app}}{V}$$
$$I = \frac{3,333,333.3 \text{ VA}}{4,700 \text{ V}}$$
$$I = 709.2 \text{ A}$$

Manufacturer B uses the same real power (2 MW) as Manufacturer A and, therefore, pays the same amount to the utility. However, Manufacturer B requires a different amount of apparent power.

$$P_{app} = \frac{P}{PF}$$
$$P_{app} = \frac{2,000,000}{.97}$$
$$P_{app} = 2,061,856 \text{ VA}$$
$$P_{app} = 2.1\text{MVA}$$

This is more than 1 MVA less than that required by Manufacturer A.

And, the current drawn by Manufacturer B is:

$$I = \frac{P_{app}}{V}$$

$$I = \frac{2,061,856 \text{ VA}}{4,700 \text{ V}}$$

$$I = 439 \text{ A}$$

Manufacturer B draws much less current to obtain the same real power. Utilities design their transmission and distribution systems based on the apparent power and the current they must deliver. Since utilities bill their customers for the true power used, utilities encourage the use of high-power factor systems.

We can use the right triangle to show the power relationship.

**Figure 2.13: Power Triangle**

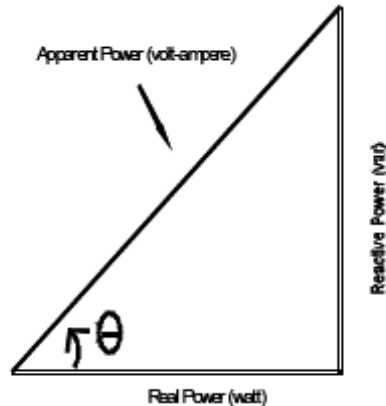

Figure 2.13 shows the following:

- The hypotenuse is the apparent power (volt-amperes).
- The adjacent side is the real power (watts).
- The cosine of the angle between the apparent power and the real power is the power factor.

### **Definition: Reactive Power**

The opposite side is called the **reactive power**. Vars are an indication of the current-voltage phase angle relationship at a given location. Vars are the product of the voltage and the out-of-phase component of AC.

- Capacitors and over-excited generators produce vars.
- Reactors and other inductive devices absorb vars.

The power factor can be changed by adjusting the amount of inductance or capacitance in the circuit. We discuss methods of accomplishing this in **Module 7: Power Transmission**.

In Figure 2.13, the apparent power leads the real power since there are positive vars. It is also possible for the apparent power to lag the real power. This occurs when there is a large amount of inductance in the circuit.

Now let's apply what we have learned to three-phase circuits.

## Section 2-4: Three-Phase Circuits

Until now, we have been discussing single-phase alternating current. Almost all electricity is generated and distributed as three-phase rather than single-phase. There are many reasons for this, including:

- The cost of a three-phase transmission line is less than an equivalent single-phase transmission line because the single-phase line requires more copper to carry the same amount of power.
- A three-phase system provides a more constant load on the generator. With single-phase current, the power required from the generator follows the current changes. Therefore, the load on the generator goes from zero to the maximum power and back to zero with each cycle. With three-phase current, at least two of the phases provide current (and therefore, power) at any instant. So, the load on a three-phase generator never reduces to zero. This uniform load allows smoother operation of the generator.

In a three-phase circuit:

- An AC voltage generator produces three evenly spaced sinusoidal voltages, identical except for a phase angle difference of  $120^\circ$ .
- Three conductors transmit the electric energy. The conductors are called phases and are commonly labeled A Phase, B Phase, and C Phase.
- Each phase conductor carries its own phase current.

Figure 2.14 shows a three-phase generator.

Figure 2.14: Three-Phase Generator

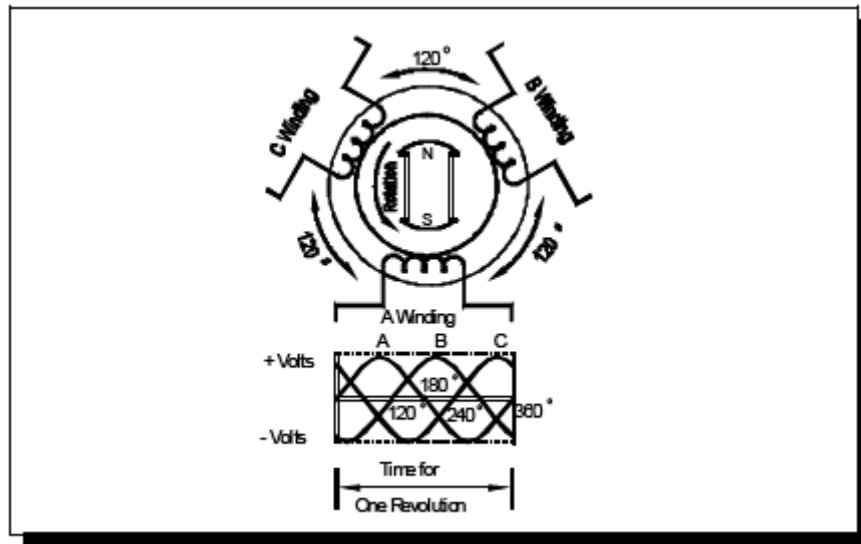

We discuss three-phase generators in **Module 4: Principles of Power Generation**. From the figure, we see that there are three windings. So, we may conclude that it would take six conductors (one for each end of a winding) to transmit the power from the generator. But this is not so. Instead, we can interconnect the three phases of a generator so only three conductors are required to carry load.

Let's examine three-phase connections.

## Three-Phase Connections

The three phases of a generator can be connected in either Delta or Wye connections. Transformers also use the same three-phase connections.

Figure 2.15: Delta Connection

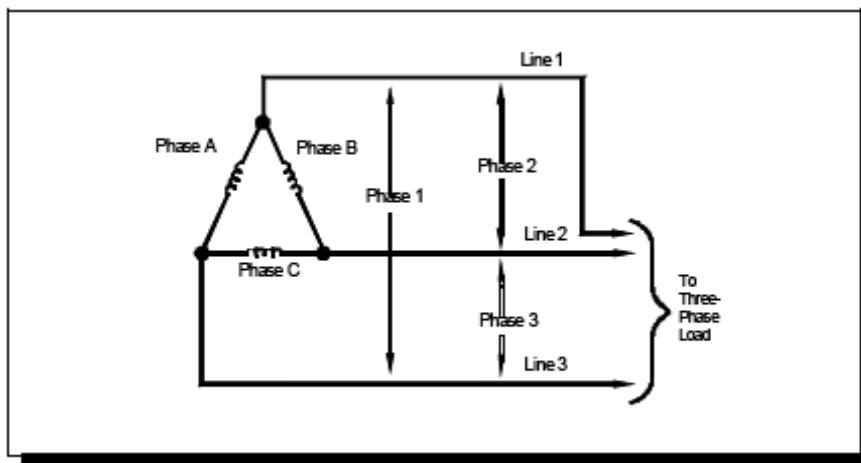

In the Delta connection:

The ends of the coils are connected together as shown in the figure. No current flows in the phase windings until a load is connected. This is because the sum of the voltages on any two of the phases is equal and opposite to the other phase.

### Definition: Phase-to-Phase and Line Voltages

The voltages between the outputs of the generator are called the **line voltages** (sometimes called **phase-to-phase voltages**).

- The line voltages are equal to the phase voltages.
- When a Delta-connected generator is loaded, current flows in the loads, lines, and phase windings.
- The line currents are not equal to the phase currents, because each line carries current from two phases. The currents from any two phases are 120° out of phase.

$$I_{\text{line}} = \sqrt{3} I_{\text{phase}}$$

$$I_{\text{line}} = 1.732 I_{\text{phase}}$$

( $\sqrt{3}$  is approximately 1.732)

Now, let's examine another winding connection – a Wye connection.

**Figure 2.16: Wye Connection**

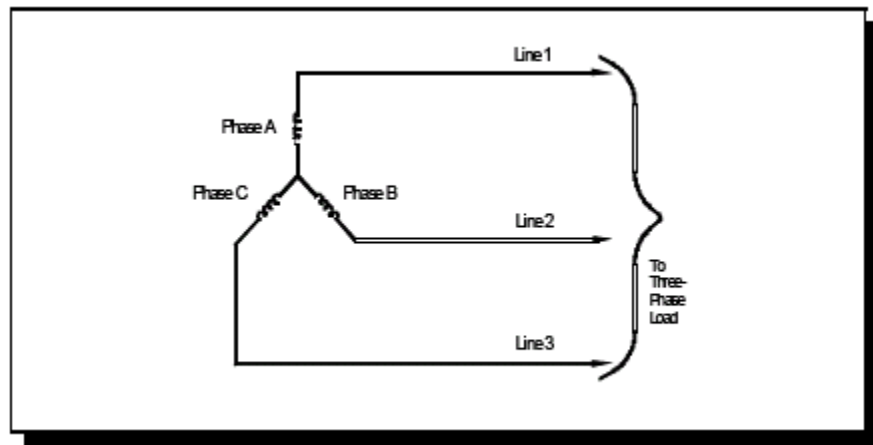

In the Wye connection:

- The windings of the generator are connected as shown – each of the coils is connected together at a common (neutral) point. The line voltages are 120° out of phase with each other.
- The line currents equal the phase currents.
- The line voltages do not equal the phase voltages. The voltage between any two lines is the result of two phase voltages 120° out of phase.

$$V_{\text{line}} = 1.732 V_{\text{phase}}$$

## Section 2-5: Electromechanics

### Definition: Electromechanical Energy Conversion

An electric generator and a motor operate using a process called **electromechanical energy conversion**. This process involves the transformation of mechanical energy into electrical energy and vice versa.

- An electric generator converts mechanical energy into electrical energy based on electromagnetic induction.
  - A voltage is induced in a conductor as the conductor moves through magnetic flux lines.
- A motor converts electrical energy into mechanical energy in the form of a rotary motion. The motor needs an electric power unit to produce the rotary motion.
  - The operation of a motor depends on the principle that a current-carrying conductor placed in (and at right angles to) a magnetic field moves at right angles to the direction of the field.

We examine generators in detail in **Module 4: Principles of Power Generation**.

A synchronous condenser is another electric machine. It is a large synchronous motor. We use a synchronous condenser to change the power factor of the system by generating and absorbing Vars on the power system. We discuss synchronous condensers in **Module 5: Substation Overview**.

**Conclusion:** This concludes the module on fundamentals of electricity. You may want to keep it handy as we apply the principles discussed in this module in the remainder of the training manual.

**Module 2: Fundamentals of Electricity  
Question Set**

## Module 2: Fundamentals of Electricity Question Set

- 2.1. Fill in each of the blank cells in the following table. (The first row has been completed for you.)

Term	Definition	Unit	Symbol
Charge	Property of electrons and protons	Coulomb ( $6.24 \times 10^{18}$ )	Q
	Flow of electrons		
		Volt	
			R
		Henry	
	Property of an electrical circuit that opposes change to voltage by using energy stored in an electric field.		

- 2.2. Answer the following questions about conductors:
- (a) True/False: A conductor is a material that has only a few free electrons.
  - (b) Name two materials that are good electrical conductors.

- 2.3.** Answer the following questions about insulators:
- (a)** True/False: An insulator is a material that has a large number of free electrons that continually jump to other atoms.
  - (b)** Name two materials that are good electrical insulators.
- 2.4.** How is alternating current different from direct current?
- 2.5.** Answer the following questions about resistance:
- (a)** What affect does a material's length have on the amount of resistance it exhibits?
  - (b)** What affect does a material's cross-sectional area have on the amount of resistance it exhibits?
  - (c)** If  $R_1 = 40\Omega$  and  $R_2 = 30\Omega$ , what is the equivalent resistance if these two resistors are in series?
  - (d)** If  $R_1 = 40\Omega$  and  $R_2 = 30\Omega$ , what is the equivalent resistance if these two resistors are in parallel?
- 2.6.** Whenever current flows in a conductor, what invisible force surrounds the conductor?
- 2.7.** A lamp has a **resistance** of 75 ohms. How much current flows through the lamp when it is connected to 120 volts?
- 2.8.** The **current** flowing through a  $5,000\Omega$  resistor is .250 A. What is the voltage drop across the resistor?

2.9. Define the term in-phase.

2.10. Define the term out-of-phase.

2.11. In an inductive circuit, the current **leads/lags** the voltage (circle one).

2.12. In a capacitive circuit, the current **leads/lags** the voltage (circle one).

2.13. What is a Var?

2.14. What is impedance?

2.15. Answer the following questions about power factor:

(a) Define power factor.

(b) What does power factor indicate?

**2.16.** List two types of three-phase connections.

**2.17.** What is a synchronous condenser?

This page intentionally left blank.



**Module 3:  
Power System Overview**

# **Module 3: Power System Overview**

## **Table of Contents**

<b>Power System Overview .....</b>	<b>3-3</b>
<b>Section 3-1: Generating Station .....</b>	<b>3-4</b>
<b>Section 3-2: Transmission System .....</b>	<b>3-6</b>
<b>Section 3-3: Transmission Substation .....</b>	<b>3-7</b>
<b>Section 3-4: Subtransmission System .....</b>	<b>3-7</b>
<b>Section 3-5: Distribution Substation .....</b>	<b>3-8</b>
<b>Section 3-6: Distribution System .....</b>	<b>3-8</b>
<b>Module 3: Power System Overview Question Set .....</b>	<b>3-9</b>

## **Table of Figures**

<b>Figure 3.1: Power System Elements .....</b>	<b>3-3</b>
--	------------

## Power System Overview

### Module Overview

The **Power System Overview** module introduces the following basic power system elements:

- Generating Station
- Transmission System
- Transmission Substation
- Subtransmission System
- Distribution Substation
- Distribution System

**Figure 3.1: Power System Elements**

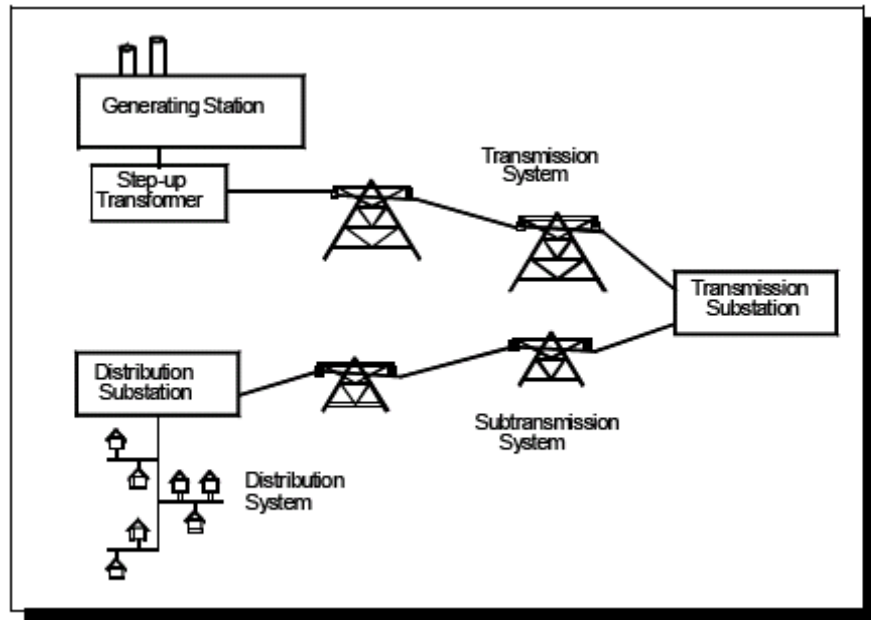

Figure 3.1 illustrates the relationship between the basic elements of the power system.

**Note:** *Figure 3.1 is a simplified drawing. In a real power system, there are many generating stations, substations, transmission lines, and distribution feeders. These elements are interconnected in a complex fashion.*

This module is intended to provide you with a general overview of the electric power system. We discuss each of the power system elements in more detail in other modules.

We begin by discussing the place where electric power is produced, the generating station.

## Section 3-1: Generating Station

A generating station supplies power to the electric system. Large-scale turbine/generator units produce alternating current (AC) power at a frequency of 60 Hertz.

Electric generators range in size from a few hundred kilowatts (kW) to over one thousand megawatts (MW).

Turbines turn large power generators to produce electricity. The turbines are driven by steam, water, combustion gases, wind, and other forces, depending on the type of plant.

You might logically think the best place to locate a generating station would be close to the customers who use the electricity. However, this is not always desirable or practical for a number of reasons:

- Large fossil fuel and nuclear steam generators require a large cooling resource. This is typically provided by a body of water, such as an ocean, lake, or river. That is why these types of power plants are typically located near water.
- Hydroelectric plants require a swift running stream or river and a significant elevation change (such as a waterfall) for effective operation.
- Wind-powered turbine generators and geothermal units must be located where these forces are available.

These conditions are not generally found in heavily populated areas. What's more, people do not find it desirable to live near a generating station. For these and other reasons, generating stations are usually located many miles from customers.

We discuss generating stations in more detail in **Module 4, Principles of Power Generation**.

The electricity produced by generating stations may be transmitted over many miles to reach customers. You may recall from reading **Module 2, Fundamentals of Electricity**, that when current flows through a conductor it loses energy. Loss

amount depends on the resistance of the conductor and the amount of current flowing through the conductor. However, you may also recall that at high voltages the losses are reduced. So to transmit the electricity over the long distances from the generating station to customers, the voltage is increased.

Generator output voltage is usually 25 kV or less. Step-up transformers outside the generating stations may increase the voltage to 230 kV, 500 kV, or 765 kV. The voltage may be increased to other voltages, depending on the individual power system. (**Refer to Module 6, Transformers**, for more information on how a transformer operates.)

Referring to Figure 3.1, we see that electricity is fed from the step-up transformer at the generating station to a transmission system.

**Figure 3.1: Power System Elements**

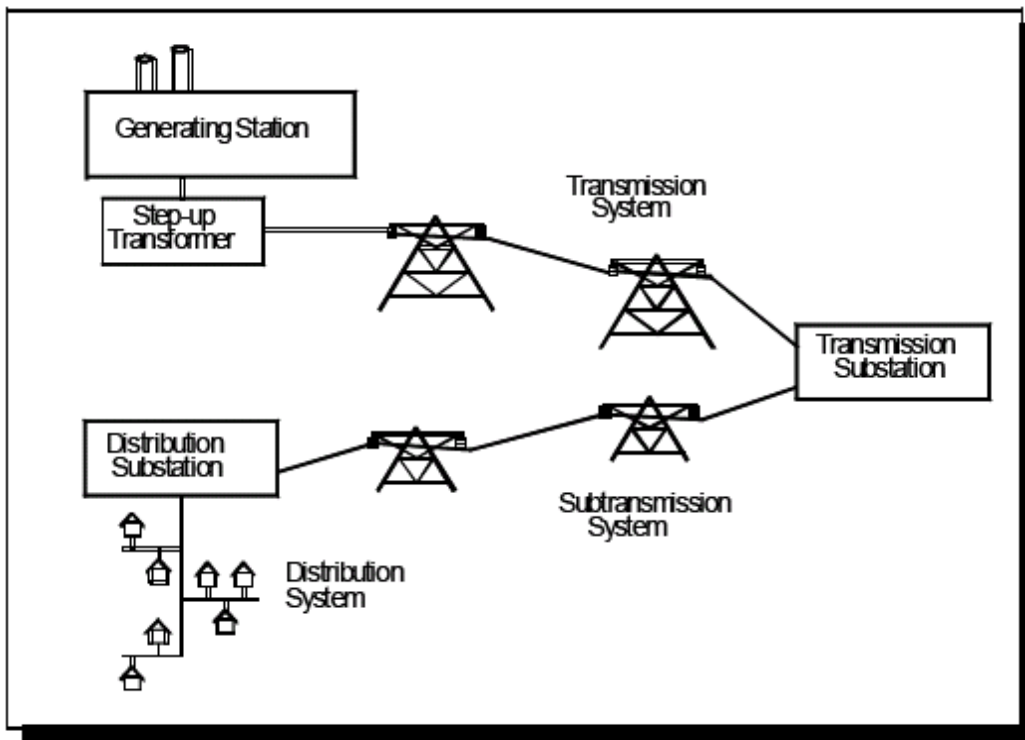

## Section 3-2: Transmission System

A transmission system is made up of high-voltage power transmission lines that transfer or "transmit" electricity from remote generating stations to customers.

Transmission lines are usually overhead wires supported by towers. Transmission lines can be several hundred miles long.

Interconnected transmission lines form a network or grid that connects generating stations to customers. Through the grid, transmission systems also provide a method of interconnecting utilities so that power can be exchanged between utilities when necessary or desirable.

Power lines that operate at the higher voltages used on a given power system make up the transmission system.

### **Definition: Extra High Voltage (EHV)**

**Extra High Voltage (EHV)** is the term given to transmission voltages above 230 kV. For example, lines operating at 345 kV, 500 kV and 765 kV are EHV lines.

### **Definition: Ultra High Voltage (UHV)**

**Ultra High Voltage (UHV)** is the term given to transmission lines above 800 kV. The use of UHV lines is still somewhat experimental in North America.

### **Definition: High Voltage Direct Current (HVDC)**

In addition to the AC lines described above, some utilities use **High Voltage Direct Current (HVDC)** transmission lines with voltages up to 1000 kV pole-to-pole.

We discuss the term pole-to-pole and other characteristics of EHV and HVDC lines in **Module 7, Power Transmission**.

Referring to Figure 3.1, we see that the power lines of the transmission system carry electricity to transmission substations. The transmission substation reduces the voltage for regional use.

### Section 3-3: Transmission Substation

A transmission substation is a facility where transmission lines terminate or connect to other transmission lines. Transmission substations contain equipment to sectionalize the power system and disconnect faulty equipment or equipment requiring maintenance from the rest of the power system.

It is usually desirable to reduce the transmission system voltage before the electricity reaches customers. Therefore, most transmission substations contain power transformers to step down the high transmission system voltages to lower subtransmission voltages.

**Definition: Switching Station**

Some transmission substations, called **switching stations**, do not contain transformers. Rather, they contain only the equipment necessary to sectionalize the transmission system. A switching station switches transmission circuits in and out of service when necessary for maintenance or to isolate a problem area.

In Figure 3.1, the power is transmitted into the subtransmission system after leaving the transmission substation.

### Section 3-4: Subtransmission System

A subtransmission facility serves as an intermediate point between the transmission system and the distribution system that supplies the electricity to customers.

Lower voltage subtransmission lines are often desirable because the wide "right-of-ways" (land areas through which the transmission lines pass) needed by higher voltage transmission lines may be unavailable in more heavily-populated areas. Subtransmission lines do not have the same right of way requirements as transmission lines.

In some cases, it is economical to branch off the transmission lines with lower voltage lines to serve small communities.

Not all utilities designate separate transmission and subtransmission lines and facilities. Some utilities' electric systems transmit power from transmission systems to distribution systems. Or, if a generating station is in or close to the customers' neighborhoods and the generating station is connected to power lines operating at subtransmission voltages, such as 69 kV and 115 kV, then power is supplied directly to the distribution substations.

## Section 3-5: Distribution Substation

A distribution substation energizes the distribution system that supplies power to customers.

Distribution substations contain power transformers that step down the high transmission or subtransmission line voltage to the primary distribution voltage. Most utilities operate their distribution system between 4 kV and 34.5 kV.

Circuit breakers for switching individual distribution circuits are typically installed at these stations. Utilities use circuit breakers to de-energize and re-energize individual distribution circuits that are faulty or require maintenance.

We see in Figure 3.1 that upon leaving the distribution substation, power is fed into the distribution system.

## Section 3-6: Distribution System

A distribution system is the final step to delivering power to customers.

### Definition: Distribution Feeders

The distribution substations supply power to the primary distribution circuits, called ***distribution feeders***. Distribution feeders are typically energized between 4 kV and 34.5 kV. The distribution feeders carry power from the distribution substations to reach the customers. Overhead wires supported by utility poles are the most common means to support the distribution feeders. Underground cables may also be used.

Most households receive power at 120 and 240 volts. Business customers may be supplied with single-phase or three-phase power up to 480 volts AC. Some business customers provide their own distribution transformers, which are supplied directly from the primary distribution feeders.

As close to the customers as possible, the primary distribution voltage is stepped down by distribution transformers to secondary voltages that can be used by the customers. Distribution transformers are usually mounted on pole-tops. Utilities also use pad-mounted transformers installed on the ground on concrete slabs or in underground vaults.

**Conclusion:** This concludes the module on power system overview. The purpose of this module is to discuss each of the basic power system elements.

Other modules provide greater detail on each of the elements.

**Module 3: Power System Overview  
Question Set**

**Module 3:  
Power System Overview  
Question Set**

- 3.1.** Explain why the voltage output of the generating station is increased prior to feeding into the transmission system.
- 3.2.** Define the following terms:
- (a)** EHV
  - (b)** UHV
  - (c)** HVDC
- 3.3.** Describe a switching station.
- 3.4.** Identify two ways distribution transformers are mounted.



**Module 4:  
Principles of Power Generation**

This page intentionally left blank.

## **Module 4: Principles of Power Generation**

### **Table of Contents**

<b>Principles of Power Generation.....</b>	<b>4-5</b>
<b>Section 4-1: Generator and Turbine Basics .....</b>	<b>4-5</b>
Generator.....	4-5
Turbine.....	4-11
<b>Section 4-2: Generator Electrical Characteristics.....</b>	<b>4-12</b>
<b>Section 4-3: Types of Generating Units .....</b>	<b>4-14</b>
Principles of Operation—Steam Generating Units .....	4-15
Fossil-Fired Units .....	4-15
Fuel Handling .....	4-17
Fuel Combustion .....	4-18
Steam Generation .....	4-19
Steam and Feedwater Cycling .....	4-19
Nuclear Units .....	4-20
Fuel Handling .....	4-20
Nuclear Reactor Basics.....	4-21
Steam Generation .....	4-22
Geothermal Units .....	4-23
Principles of Operation—Hydroelectric Generating Units.....	4-24
Characteristics of Hydraulic Turbines .....	4-25
Types of Hydroelectric Stations .....	4-26
Principles of Operation—Combustion Gas Turbine Units.....	4-27
Principles of Operation—Combined-Cycle Units .....	4-28
Principles of Operation—Wind Turbines .....	4-29
Types of Wind Turbines .....	4-30
Sizes of Wind Turbines .....	4-30
Inside the Wind Turbine .....	4-31
Advantages and Disadvantages of Wind Energy.....	4-33
History of Wind Energy .....	4-34
Wind Energy Resource Potential .....	4-35
<b>Section 4-4: Generating Unit Operating Characteristics .....</b>	<b>4-36</b>
Efficiency.....	4-37

Steam Generating Units .....	4-37
Hydroelectric Generating Units .....	4-38
Unit Capability and Minimum Load .....	4-38
Steam Generating Units .....	4-38
Hydroelectric Generating Units .....	4-39
Response Rate.....	4-39
<b>Module 4 Principles of Power Generation Question Set.....</b>	<b>4-41</b>

## **Module 4: Principles of Power Generation**

### **Table of Figures**

Figure 4.1: Single-Phase AC Generator.....	4-6
Figure 4.2: Excitation System.....	4-7
Figure 4.3: Three-Phase AC Generator .....	4-9
Figure 4.4: Vee Curve for Synchronous Machines.....	4-12
Figure 4.5: Generator Characteristic Curve.....	4-13
Figure 4.6: Fossil-Fired Steam Unit.....	4-16
Figure 4.7: BWR.....	4-22
Figure 4.8: PWR.....	4-23
Figure 4.9: Hydroelectric Generating Unit .....	4-24
Figure 4.10: Pumped Storage Station - Pumping Cycle .....	4-26
Figure 4.11: Pumped Storage Station – Generating Cycle.....	4-27
Figure 4.12: Wind Turbine.....	4-30
Figure 4.13: Inside the Wind Turbine .....	4-31

## Principles of Power Generation

### Module Overview

The **Principles of Power Generation** module presents the following topics:

- Generator and Turbine Basics
- Generator Electrical Characteristics
- Types of Generating Units
- Generating Unit Operating Characteristics

While a wide variety of basic generating unit designs exist, almost all share two common components: a generator and a turbine. Therefore, we begin this module by discussing the generator and turbine functions, and design concepts.

### Section 4-1: Generator and Turbine Basics

First, we discuss the basic operating principle of alternating current (AC) generators. Then, we examine the basic operating principle of turbines.

#### ***Generator***

You may recall from reading ***Module 2: Fundamentals of Electricity*** that we discuss the principle of electromagnetic induction. This principle states that:

When a conductor moves and cuts (or passes) through a magnetic field or, a magnetic field moves and cuts or passes through a conductor, a voltage is generated (or induced) in the conductor.

Generator operation is based on the principle of induced voltage. When the generator shaft rotates, a conductor loop is forced through a magnetic field and voltage is induced in the conductor.

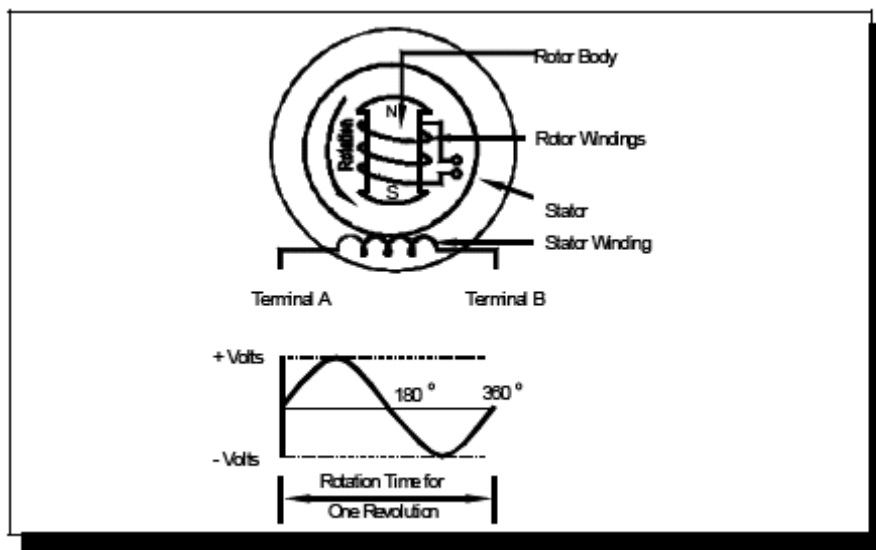
**Figure 4.1: Single-Phase AC Generator**

Referring to Figure 4.1, the following steps represent the operating principle of the generator:

A direct current (DC) energy source (not shown in this figure) supplies current to the rotor windings. The rotor acts as a large electromagnet that produces a magnetic field (flux) in the rotor body.

**Note:** Figure 4.1 shows this magnetic flux as a two-pole magnet. In reality, this magnet does not exist. Rather, the rotor's core provides the path of the magnetic lines.

### Definitions: Armature and Stator

The turbine rotates the rotor within the stator. (The figure shows the direction of the rotor rotation.) The **stator**, also called the **armature**, is the non-rotating part of the generator.

As the rotor rotates, the magnetic field cuts the stator winding. Based on the principle of electromagnetic induction, this induces a voltage in the stator winding. (This is the conductor loop that is forced through a magnetic field.)

The voltage can be measured between Terminal A and Terminal B and is the generator output. We can see from the graph of the output that the voltage is not constant—it builds from zero to a maximum voltage and then back to zero—twice in one revolution.

On each rotation, the stator winding is cut by the north and south poles, the generator voltage alternates between positive and negative. The voltage output is a

sine wave. As the voltage alternates, the resulting output current is alternating current (AC).

In our first statement about Figure 4.1, we said that a direct current energy source supplies current to the rotor windings. An excitation system supplies the direct current to the rotor windings.

Figure 4.2 shows a diagram of an excitation system.

**Figure 4.2: Excitation System**

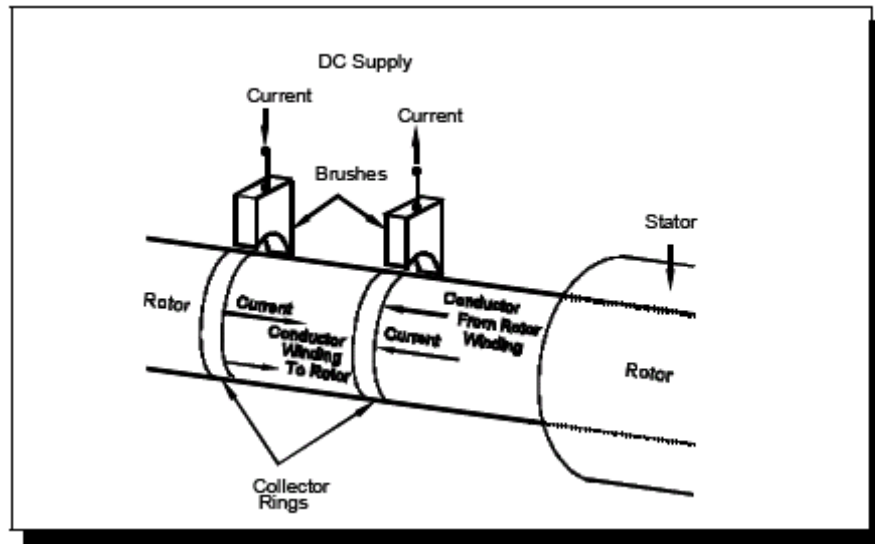

Figure 4.2 illustrates the following sequence of events:

- The DC supply feeds direct current through a brush that makes contact with a collector ring. The collector ring is mounted on the turbine rotor.
- Direct current then flows through the collector ring to the conductors mounted on the rotor shaft.
- The current then flows to the rotor windings, which are coils of the conductor connected to the collector ring.
- Direct current flows through the rotor windings (creating a magnetic field) and exits the rotor through the conductor. Another collector ring feeds current to a brush and back to the DC supply.

Brushes and collector rings are high-maintenance items. Therefore, some generator designs use a "brushless" excitation system that eliminates the need for brushes and collector rings.

In a brushless exciter system, a synchronous generator (three or more phases) — in which the AC windings rotate and the field windings are stationary — is added to the shaft. Power flows through the conductors in the shaft and is rectified to direct

current on the generator rotor. The field of the synchronous generator exciter is excited from an amplifier.

Power system voltage is an important quantity. Ideally, a constant voltage is desirable at all times.

The excitation system can perform a number of control functions. The excitation system increases and decreases the current flow to the rotor. Excitation control can be performed either manually by a plant operator or automatically by a generator voltage regulator.

The generator voltage regulator controls the generator excitation system.

- Under normal conditions the voltage regulator controls the terminal voltage within pre-defined limits.
- During abnormal conditions when there are sudden system voltage changes, the voltage regulator rapidly returns the voltage to normal. Control circuits provide the voltage regulator with this capability.

The excitation system performs the following control functions:

### **Maintains generator voltage**

For example: a sudden drop in load causes generator over-voltage. The excitation system quickly reduces the exciter voltage.

### **Controls reactive power flow**

Another control system applied at a generator is a power system stabilizer (PSS). The function of the PSS is to change the voltage regulator's output based on various inputs. A PSS assists in damping power system oscillations. The PSS monitors generator variables (such as current, voltage, and shaft speed), processes the data, and sends control signals to the voltage regulator.

Hydrogen gas fills the generator. The gas circulates through the generator to remove heat from the windings and the core. Gas coolers cool the hydrogen after it passes through the generator.

Up to this point, we have been discussing single-phase power generation. Now, let's see what happens if we replace the single-phase stator winding with three sets of windings.

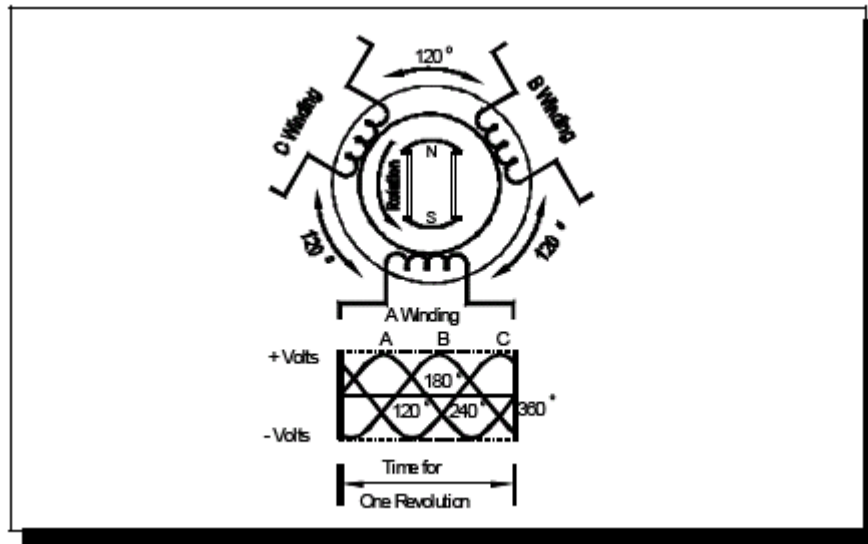
**Figure 4.3: Three-Phase AC Generator**

By adding two stator windings to our single-phase generator we find that each winding produces a single-phase output voltage that is separate from the others. The sine wave voltage is the same magnitude for each of the phases but separated by 120°.

The three phases of the generator can be interconnected so that the power can be carried on only three conductors. Therefore, only three conductors are needed to carry three-phase power from the generating station to the customer.

The three phases of a generator can be connected in either a delta or wye connection. **Module 2: Fundamentals of Electricity** discusses delta and wye connections.

Generator leads connect the generator to a main circuit breaker. The circuit breaker is connected to the power system.

### **Definition: Synchronism**

Before closing the generator circuit breaker, the generator voltage must be synchronized to the power system voltage. **Synchronism** is the condition when connected AC systems, machines, or a combination of the two operate at the same frequency and when the angle displacement between voltages in them is constant, or varies about a steady or stable position.

**Definitions: Stator Field and DC Field**

Prior to synchronizing, there is no current flowing in the armature windings. When the generator is connected to the power system, current flows in the armature windings creating a revolving magnetic field called the **stator field**. From previous discussions, we know there is also a magnetic field in the rotor body called the **DC field**.

- The stator field is a result of the three-phase currents interacting to produce a rotating field from fixed windings.
- The DC field is a result of the rotation of the rotor.

**Definition: Rotor Angle**

While the generator rotor is rotating at synchronous speed and the DC field is rotating at synchronous speed, the stator field is also moving at synchronous speed in the same rotation direction as the DC field. However, the DC field is slightly advanced from the stator field – there is an angular difference between these two fields. This angle is called the **rotor angle**. The greater the mechanical input to a generator, the greater the rotor angle advancement, and the greater the electrical power output.

The interaction between these two fields is how power is transferred from the prime mover, the turbine, to the power system.

- Under normal conditions, the two fields rotate at the same speed.
- When small load changes occur, the angular difference between the two fields increases slightly, but the generator adjusts to this new angle.
- When a sudden or large load change occurs, the angular difference between the two fields increases suddenly and the generator may not be able to adjust to this new angle to meet the new power requirement.

When the rotor angle becomes too large, the magnetic force cannot hold the rotor in synchronism. This creates a situation where the generator loses synchronism with the power system and most likely trips off-line. Under this condition, the generator is said to be out of step with the power system.

To synchronize the generator to the power system, the turbine speed must be adjusted. These adjustments are performed automatically by an automatic synchronizer or manually by a plant operator observing a device called a synchroscope.

Once the generator is synchronized to the power system, the circuit breaker can be closed and power is sent to the system. You may recall reading in **Module 3: Power System Overview** that a step-up transformer at the generating station steps up the generator voltage to transmission levels for transmission to customers.

The generator's output voltage is dependent on:

- number of turns in the stator (armature) winding
- magnetic field strength (the number of lines of flux produced by the field)

The generation output frequency is determined by:

- number of pairs of magnetic poles in the generator rotor
- rotor's rotational speed (the revolutions per minute of the generator shaft)

Most of these variables are determined during the design and construction of the generator.

For the two-pole generator, each shaft revolution produces one cycle. If the generator rotates at 3,600 revolutions per minute, this is equal to 60 cycles per second. Recall from **Module 2: Fundamentals of Electricity** that one cycle per second is a hertz. So, 60 revolutions per second equals 60 cycles per second (hertz) or 3,600 revolutions per minute.

The generator output frequency (f) is:

$$f = \frac{\text{Revolutions/minute}}{60} \times \text{pairs of poles}$$

With this formula, the frequency is in the base units of hertz (Hz).

## ***Turbine***

The generator rotor is connected to the turbine via a shaft. The turbine converts the high-pressure driving force created by steam, water, or combustion gas into rotation energy (mechanical energy) that turns the generator rotor.

Steam enters the turbine and passes through a series of stages. Each stage consists of:

### **Definitions: Nozzle Partitions and Buckets**

- a set of stationary blades called ***nozzle partitions***
- moving blades, sometimes called ***buckets***, attached to the rotor

The nozzle partitions direct the steam against the buckets. The buckets act like a powerful windmill to turn the turbine shaft.

Later in this module we discuss the turbine's role in more detail when we examine the different types of generating units. But first, let's look at the electrical characteristics of the generator.

## Section 4-2: Generator Electrical Characteristics

Not all generators can produce the same output. The turbine capability and the heating of its various parts limit the generator's output.

### Definition: Vee Curve

Figure 4.4 shows the relationship between the stator current and the direct current (field current) for synchronous machines. This graphic is called a **Vee Curve**. All synchronous machinery exhibits this characteristic.

Figure 4.4: Vee Curve for Synchronous Machines

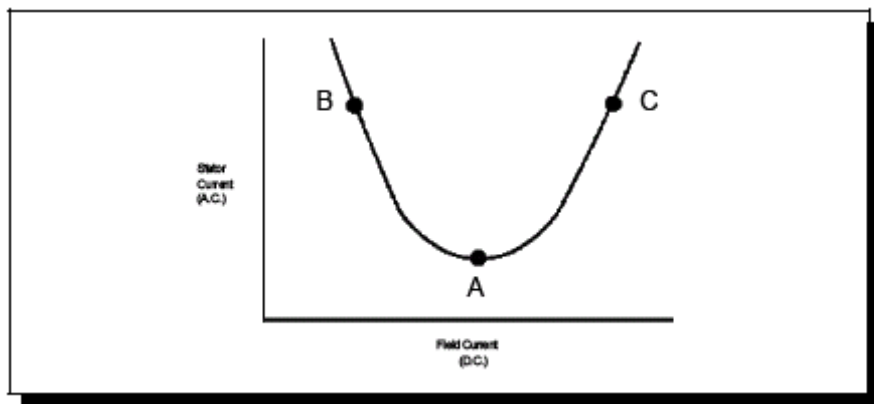

Figure 4.4 illustrates the following:

### Definition: Unity Power Factor

At Point A, the stator current is at its minimum value. The machine is operating at **unity power factor**, neither absorbing nor supplying Vars to the system.

- If the field current decreases to Point B, the stator current increases and the generator absorbs Vars from the power system.
- If the field current increases from Point A to Point C, the stator current again increases but now the generator supplies Vars to the power system.

- When the stator current increases, the stator windings heat up. The stator current's magnitude determines the amount of heat produced.
- When the field current increases, the rotor heats up. The field current's magnitude determines the amount of heat produced.
- The generator's cooling system dissipates some of this heat. However, excessive amounts of heat damage the generator.

### Definition: Generator Characteristic Curve

To avoid generator damage, manufacturers provide a graph called a **generator characteristic curve**. The generator characteristic curve shows the capability of a generator. Manufacturers recommend operating the generator within the curve boundaries. A characteristic curve shows the real power and reactive power output from a generator.

Figure 4.5 shows a generator characteristic curve.

**Figure 4.5: Generator Characteristic Curve**

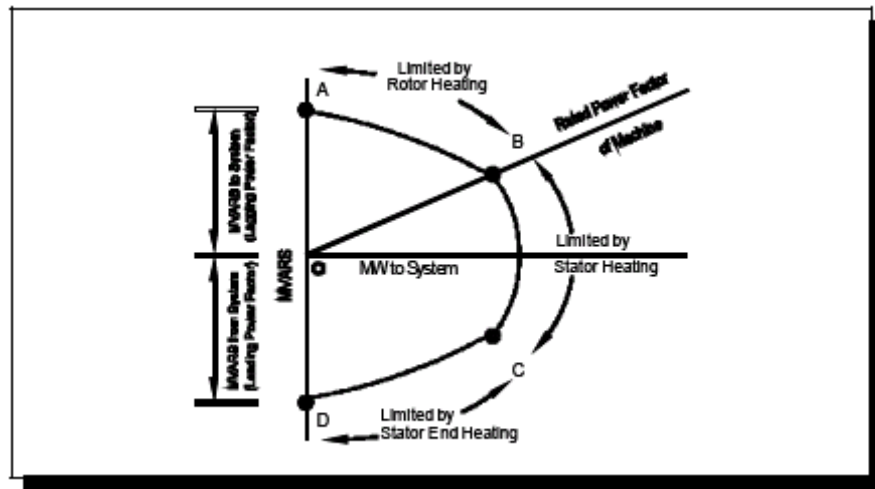

Figure 4.5 illustrates the following:

- The horizontal axis indicates generator MW output. The power of the turbine limits the MW output of the generator.
- The vertical axis indicates Mvars. Operation of the generator in the upper portion indicates the generator is supplying Mvars to the system (lagging). Operation of the generator in the lower portion indicates the generator is absorbing Mvars from the system (leading).

- The graph shows three curves. The most affected generator component determines the curve's boundary (the limit).
  - Curve A to B: Operation in this region is from zero power factor lagging to the rated power factor of the machine. The generator is over-excited. The field current is the limiting component in this region.
  - Curve B to C: Operation in this region is from the rated power factor through unity (zero Mvars) to a leading power factor. The stator current is the limiting component in this region.
  - Curve C to D: Operation in this region is from leading power factor to zero power factor. Operation in this region causes excessive heating of the stator. The generator is underexcited. Operation in this region can have an adverse affect on stability. (We discuss this earlier in this module. Excessive underexcitation weakens the magnetic link between the stator and the rotor and can cause the generator to go out-of-step with the system.)

Now that we have examined the generator and turbine basics and some of the generator's electrical characteristics, we are ready to begin our discussion on the different types of generating units.

### **Section 4-3: Types of Generating Units**

From our discussion on generators, we know that a prime mover, the turbine, supplies power to the generator by turning the rotor. The methods of turning the rotor vary, but all involve converting energy from a primary form to an electrical form.

In this section, we discuss the principles of operation for the following types of generating units:

- **Steam Generating Units** — Steam, produced by combustion fuel (coal, oil, gas, and combustible waste products) and nuclear boilers, drives the turbine. In some cases, the turbine is driven by geothermal steam which is naturally available close to the earth's surface.
- **Hydroelectric Generating Units** — Water flowing from higher to lower elevations drives the turbine.
- **Combustion Turbine Units** — Burning fossil fuels produce combustion gas that directly drives the turbine.
- **Combined Cycle Units** — Combine the technology of the steam and combustion turbine units.

The principles of operation for each of these four types of generating units are examined in the following sections. Other energy sources we do not discuss in detail in this module include fuel cells, solar cells, wind, and diesel fuel.

## **Principles of Operation—Steam Generating Units**

In general, the conversion from fuel to energy that can rotate the generator involves the following steps:

- A chemical or nuclear reaction from the fuel produces heat.
- The heat turns water into steam.
- The steam, directed at the turbine blades, turns the turbine.
- The turbine turns the generator.

We discuss three types of steam generating units:

- Fossil-Fired Units
- Nuclear Units
- Geothermal Units

We begin with fossil-fired units.

### ***Fossil-Fired Units***

Fossil-fired steam units use coal, oil, or gas fuel. Figure 4.6 shows a simplified drawing of a fossil-fired steam unit.

**Figure 4.6: Fossil-Fired Steam Unit**

Figure 4.6 illustrates the following process:

- Fuel (coal, oil, or gas) burns in the furnace, producing heat.
- The heat boils water in the boiler and changes the water to steam.
- The steam flows to the turbine via the main steam line where nozzles direct the steam flow against the turbine blades. This causes the turbine to rotate and drive the rotor in the generator.
- After the steam turns the turbine, it flows into the condenser or directly to the feedwater heater.

**Definition: Condensate**

In the condenser, cool, circulating water flowing through tubes condenses the steam back to water. This water is now called **condensate**.

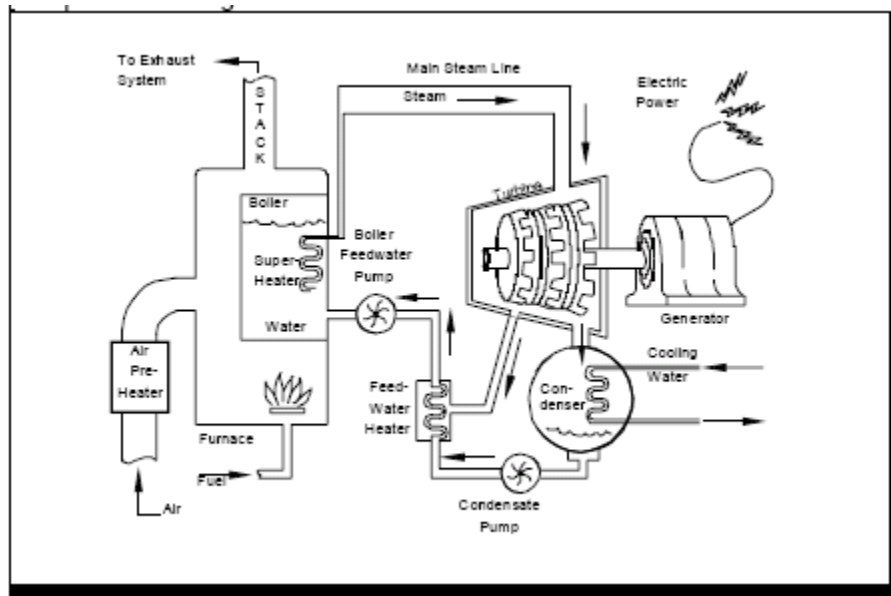
- The condensate pump directs the condensate through a feedwater heater that preheats the condensate.
- The boiler feedwater pump adds pressure to the condensate to force the water back to the boiler.

Now, let's look at the functions of some of the components identified in Figure 4.6 by discussing the following four topics:

- Fuel Handling
- Fuel Combustion
- Steam Generation
- Steam and Feedwater Cycling

### **Fuel Handling**

To keep the generating units running continuously, a tremendous amount of fuel must be readily available in a form that is suitable for burning. The facilities needed for fuel storage and pre-processing vary depending on the type of fuel used. The three types of fuel most commonly used in fossil-fired units are coal, oil, and natural gas. Let's examine the fuel handling process for each of these fuel types beginning with coal.

#### **Coal**

Ships or railroad cars deliver coal to generating stations. Some generating stations in coal-mining areas have conveyor belts for delivering coal directly from the mine to the plant.

Coal typically comes in big chunks that pass through a crusher to reduce the chunks to about three inches or less in diameter. The crushed coal is then piled up next to the generating station.

Conveyor belts transport the crushed coal from the piles into the plant to be burned. The belts pass through metal separators (essentially big magnets) to remove scrap metals from the coal. The coal is then fed to pulverizers, which grind the coal into a fine dust that is "blown" into the boiler to be burned.

#### **Oil**

Ships, trucks, or pipelines deliver oil to generating stations. The oil is stored in large cylinder-shaped tanks on-site. The oil is pumped from the tanks into the plant.

Thick oil is generally used for generating unit fuel. Preheating the oil reduces its viscosity before pumping it to the oil burners. The burners "atomize" the oil either mechanically or by steam and then spray the oil into the combustion chamber of the boiler.

## Natural Gas

Typically, pipelines deliver natural gas to generating stations on an as-needed basis. Natural gas-burning plants need almost no fuel-handling equipment. Only pressure-regulating valves and flow measuring equipment are required.

Now, let's examine the fuel combustion process. We describe a typical process. Details vary from plant to plant.

## Fuel Combustion

The fuel burns in the furnace. The heat from the burning fuel produces steam in the boiler. Boilers are large structures (up to 10 or 15 stories high), typically the tallest part of the generating station building.

### Definition: Waterwall

The inside surfaces of the boiler are called the **waterwalls**, which consist of tubes through which heated water flows. The waterwalls contain openings through which fuel burners spray the fuel. While the boiler is operating, the furnace fills with a massive "fireball" that heats the waterwalls.

### Definition: Superheater

As hot gases created by combustion leave the furnace, the gases flow past more tube sections called **superheaters**. The superheaters deliver additional heat to the water and steam. Exhaust gases may also flow through air heaters to warm the incoming air to the boiler.

### Definitions: Precipitators, Bag Houses, and Scrubbers

After as much heat as possible is extracted, the exiting gases pass through **precipitators** or **bag houses** to remove solid particles. **Scrubbers** absorb pollutants such as Sulfur Dioxide (SO<sub>2</sub>). Other emission control equipment may also be used. The remaining gases flow out the stack and are dispersed into the atmosphere.

## **Steam Generation**

Two main types of boilers are found in steam generating units: drum-type and once-through.

- **Drum-Type Boilers** — Drum-type boilers have a large cylinder (the steam "drum") mounted at the top of the boiler and connected to the tubes in the boiler waterwalls. Steam bubbles formed in the tubes rise up to the drum where the steam collects before it flows to the turbine. During normal operation, water partially fills the drum and steam occupies the remaining space. Water recirculates within the boiler.

Steam leaving the drum passes through additional tubing, which is the superheater. The superheater provides additional heat to the steam by using the hot gases that exit the boiler.

- **Once-Through Boilers** — Once-through boilers have no steam drum. Instead, the water gradually changes over to steam while being heated. The tubes entering the boiler contain only water. The tubes leaving the boiler to the turbine contain only steam.

Boilers in modern steam generating stations operate at pressures up to 3,500 pounds per square inch (psi) with temperatures ranging from 1,000° F to 1,100° F.

As steam flows out of the boiler to the turbine, it is necessary to pump water back into the boiler; otherwise, the boiler runs dry and stops producing steam. Steam generating units are designed to re-use as much of the steam as possible, first converting (condensing) the steam back to water, then pumping the water back to the boiler.

## **Steam and Feedwater Cycling**

### **Definitions: Condenser and Circulating Water**

Steam flows from its point of highest pressure in the boiler superheater, through the turbine, to the **condenser**. The condenser is a large chamber below the turbine that has a very low (almost a vacuum) pressure. The condenser contains tubes through which cold water, called **circulating water**, passes. Steam from the turbine contacts these cold water tubes and condenses back to water, called condensate. This produces the vacuum in the condenser.

Usually, circulating water pumps draw circulating water from a large body of water (e.g., an ocean, a large lake, or a river). The circulating water is pumped through the condenser tubes and then returned to its source (re-circulated) after cooling. The circulating water's temperature is raised several degrees as the steam is condensed.

**Definition: Cooling Tower**

In many locations, environmental regulations mandate that this heat be removed before the circulating water is returned to the source. In such cases, giant heat exchangers, called **cooling towers**, may transfer the excess heat into the air.

At the condenser's bottom, water from the condensate collects in the hotwell. The condensate is then pumped back to the boiler, completing the steam-water cycle.

It is not wise to pump the relatively cold (approximately 100°F) water from the hotwell to the boiler because adding cold water to the water already in the boiler decreases the temperature of the boiler water. Also, the great temperature differences can damage the boiler.

**Definition: Feedwater**

To avoid these problems, the condensate is pumped to feedwater heaters where it is preheated before being pumped to the boiler. Upon entering the feedwater heaters, condensate is called **feedwater**.

The feedwater heaters transfer heat to the condensate from steam that has passed through some of the turbine blades but has not been delivered to the condenser. Through this process, the feedwater temperature is raised several hundred degrees Fahrenheit before it is pumped into the boiler. This improves the overall plant efficiency.

Now, let's look at how a nuclear unit operates.

***Nuclear Units***

To compare and contrast nuclear-powered units with fossil-fired units, we discuss the following topics:

- Fuel Handling
- Nuclear Reactor Basics
- Steam Generation

**Fuel Handling**

As you may recall from our previous discussion, utilities store fossil fuels outside the plant and continuously send the fuel into the boiler whenever the unit is running.

**Definition: Refueling Outage**

The fuel handling process is entirely different in nuclear-powered plants. All nuclear fuel is stored inside the nuclear reactor itself. When the fuel is used up, the unit is shut down and fuel is reloaded. This is called a **refueling outage** and is usually combined with a maintenance outage. Nuclear units require a refueling outage approximately every 18 months.

**Definition: Bundles**

The nuclear fuel is a uranium dioxide (UO<sub>2</sub>) compound consisting of natural uranium (U-238) and uranium isotopes, such as U-235. The fuel comes in small, cylindrical pellets measuring about 0.4 inches in diameter and 0.4 inches in height. Fuel rods contain stacks of pellets. The fuel rods are about 12 feet long. Groups of fuel rods, called **bundles**, are mounted vertically inside the reactor.

**Nuclear Reactor Basics****Definition: Nuclear Fission**

In a nuclear-powered unit, the heat required to produce steam is generated in a nuclear reactor by a process called **nuclear fission**.

- When an atomic particle, called a neutron, collides with an atom of a radioactive material such as uranium, the nucleus of the uranium atom splits into numerous fragments.
- Each collision releases a small amount of energy in the form of heat. Some fragments collide with other atoms, causing these atoms to split and generate additional heat.
- Within the nuclear reactor, millions of these reactions take place continuously, creating large amounts of heat used to boil water.

This reaction must be controlled. Certain materials, such as boron and carbon, can absorb neutrons and other particles. This prevents them from causing additional fission reactions. Reactor control is accomplished with rods made of boron or carbon.

- Inserting a carbon or boron fuel rod reduces the amount of particles that can cause reactions. This reduces the amount of heat generated.
- Withdrawing a carbon or boron rod increases the number of reactions and increases heat production.

Nuclear reactors include hundreds of these fuel rods. Fully inserting all rods shuts down the unit.

## Steam Generation

When water is pumped into the reactor, it flows around the fuel rods where heat is generated and transferred to the water.

The method of generating steam in a nuclear unit varies depending on the design of the unit. Two basic nuclear reactor designs are in use:

- Boiling Water Reactor (BWR)
- Pressurized Water Reactor (PWR)

Figure 4.7 shows a BWR.

**Figure 4.7: BWR**

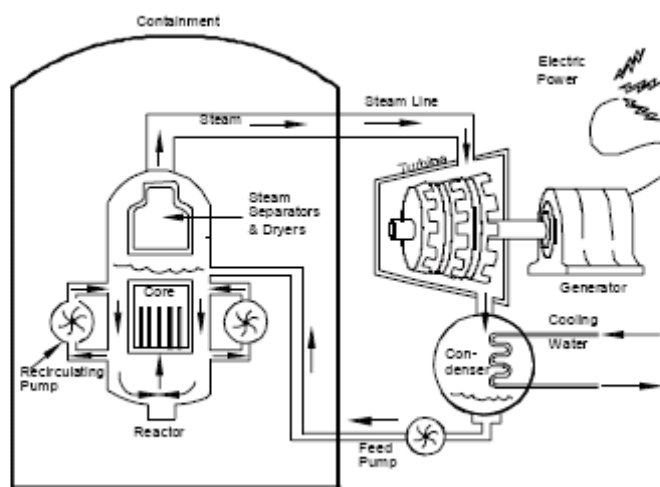

Figure 4.7 illustrates the following process within a BWR containment vessel:

- Feedwater enters the reactor vessel at the top of the core. The feedwater is added to the recirculation water and driven around the core by jet pumps.
- The boiling of water occurs within the reactor vessel in the reactor itself.
- The steam and water mixture pass through steam separators and dryers mounted over the core. The steam separators dry the steam by removing remaining water droplets.
- The steam line delivers the steam to the turbine.

Figure 4.8 shows a PWR.

**Figure 4.8: PWR**

Figure 4.8 shows the following process within a PWR containment vessel:

- Boiling does not occur in the reactor. Heated water circulates between the reactor vessel and one or more steam generators.
- In the steam generators, the heat generated by the pressurized water from the reactor boils water in a separate loop. This loop transfers the steam to the turbine.

Once the steam leaves the BWR or PWR reactor containment vessel, the steam/feedwater cycle is basically the same as in fossil-fired units.

The last type of steam generating unit we examine is the geothermal unit.

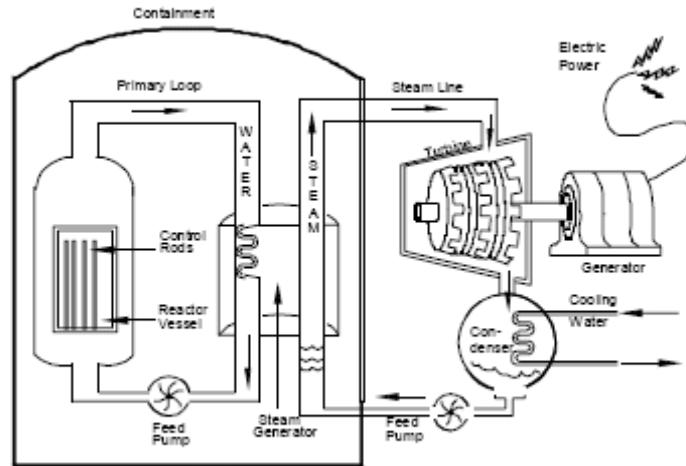
## ***Geothermal Units***

### **Definitions: Fissures and Brine**

Geothermal generation relies on thermal energy originating within the Earth's core and transferred through fissures to the surface by steam or hot brine.

**Fissures** are breaks or cracks of considerable length and depth in the Earth's surface. **Brine** is water saturated with salt and other minerals. Heat extracted from the geothermal energy source generates steam that drives the turbine.

There are two basic kinds of geothermal units:

- Dry steam—Superheated geothermal steam directly drives turbine-generators and then is condensed, cooled, and reinjected into the earth.
- Wet steam—In wet steam plants, two approaches are available:
  - Hot brine flows naturally into wells where the pressure release causes boiling. It is commonly stated that the water is "flashed" into steam. The steam drives the low-pressure steam turbine.
  - The brine heats a secondary (working) fluid with a lower boiling temperature than water. Then vapor from the boiling secondary fluid drives the turbine.

While geothermal energy exists over the entire extent of the earth's surface, the ease and cost of using this heat source varies widely. In the United States, this type of energy source is limited to areas in the western third of the country where favorable steam conditions (80-90 percent moisture) make it feasible.

Now, let's examine another type of generating unit, a hydroelectric generating unit.

## Principles of Operation—Hydroelectric Generating Units

Similar to steam-powered generating units, hydroelectric generating units apply a powerful driving force to a turbine that turns a generator to produce electrical energy. However, in hydroelectric units, the turbine's driving force is supplied by the flow of water from a higher elevation to a lower elevation.

Figure 4.9 shows the principle components of a hydroelectric generating unit.

**Figure 4.9: Hydroelectric Generating Unit**

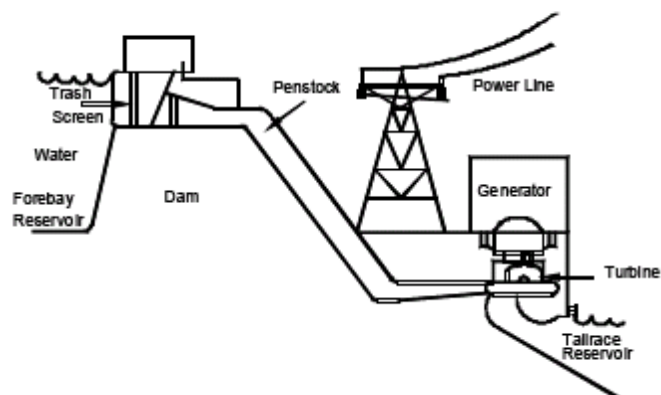

Figure 4.9 illustrates the basics of hydroelectric generation:

A water source, usually a river or a series of streams, supplies water to a reservoir.

**Definitions: Forebay or Upper Reservoir**

A concrete or earthen dam across a river blocks the water flow to form a reservoir, called the ***forebay reservoir or upper reservoir***.

**Definition: Penstock**

- A water pipe or conduit, called the *penstock*, carries water from the forebay (upper) reservoir to the turbine. A penstock shutoff valve is installed at the downstream end of the penstock.
- A hydraulic turbine-generator system transforms the driving force of flowing water into electrical energy.

**Definitions: Tail-water or Tailrace Reservoir**

The turbine discharges water into a lower reservoir, called the ***tail-water reservoir or tailrace*** or tailway reservoir.

**Definition: Head**

The power generated by a hydroelectric generator depends on:

- The ***head***, the difference between the water level at the forebay reservoir and the water level at the tailrace reservoir.
- The amount of water flowing to the turbine.

***Characteristics of Hydraulic Turbines***

Like steam-powered turbines, hydraulic turbines use blades or buckets shaped and positioned so that the water's force causes the turbine to rotate. The turbine runner is the portion of the turbine on which the blades or buckets are mounted.

**Definition: Wicket Gates**

Moveable vanes, called ***wicket gates***, regulate the turbine power output by controlling the amount of water that enters the turbine runner.

Utilities use two basic types of turbines at hydroelectric generating stations:

- Impulse — Nozzles direct high velocity water onto cup-shaped buckets. This type of turbine is commonly used for plants having a high head (greater than 1000 feet).
- Reaction — Turbine output is obtained from a combination of the water pressure and velocity that completely fills the turbine water passages and runner.

### ***Types of Hydroelectric Stations***

There are two basic designs for hydroelectric stations, depending on the station's location:

- Run-of-River Hydroelectric Stations

A run-of-river hydroelectric station is located at the dam itself, so that separate canals or pipelines are not required. There is very little storage capability behind the dam. Water flows directly from the penstock behind the dam, through the turbine, and then downstream. In some situations, run-of-river stations include large storage reservoirs. Run-of-river plants therefore capture the natural flow rate of a river or stream.

- Pumped Storage Hydroelectric Stations

A pumped storage hydroelectric station has two reservoirs: an upper reservoir and a lower reservoir. The upper reservoir may be a lake with natural inflow or an artificial lake with no inflow. Pumped storage facilities use a special type of reversible turbine that can be used either as a conventional generator or as a pump. During times of excess energy, water is pumped from the lower reservoir to the upper reservoir and used later during peak periods.

Figures 4.10 and 4.11 illustrate the two cycles of a pumped storage station.

**Figure 4.10: Pumped Storage Station - Pumping Cycle**

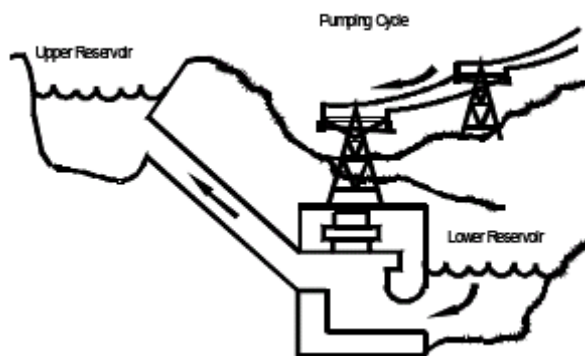

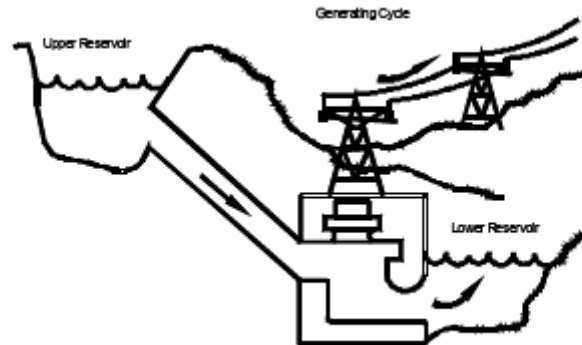
**Figure 4.11: Pumped Storage Station – Generating Cycle**

Figures 4.10 and 4.11 show the two operating modes of a pumped storage station:

- During the off-peak hours, pumping raises the water to an upper reservoir. In the pumping mode (Figure 4.10), the generator is operated as a motor and the hydraulic turbine is operated as a pump.
- During peak hours, the water returns through the turbine, driving the generator to produce electric energy (Figure 4.11). Fifty to seventy percent of the energy used to pump water to the upper reservoir, depending on the net head and the number of pumps running at any given time, is usually recovered in generation when the water is released.

The next type of generating unit we discuss is the combustion gas turbine.

## Principles of Operation—Combustion Gas Turbine Units

The operation of combustion gas turbines is similar to the operation of a jet engine. A combustion turbine changes the chemical energy of fuel directly into mechanical energy and then into electrical energy. Unlike steam turbines, combustion turbines eliminate using steam for thermal energy.

- Air is pressurized in a compressor and then enters a combustion chamber.
- In the combustion chamber, the air mixes with fuel (oil or gas) and burns.
- The high-temperature, high-pressure combustion gas then expands in the turbine, providing the power needed to drive both the generator and the compressor.

There are two basic designs for combustion gas turbines:

- Open-cycle—Expanded gas is exhausted into the atmosphere, as with an aircraft jet engine.

- Closed-cycle—Exhaust gas goes to a heat exchanger, where it is cooled and then readmitted to the compressor for another cycle.

The main advantage of the closed-cycle design is its cleanliness, due to the recycling of exhaust gases. However, closed-cycle units have more components and are more difficult to control.

Combustion gas turbines offer the advantage of quick start-up, low investment cost, and short delivery time. However, their thermal efficiency is low. They are capable of rapid start-up and loading (5-10 minutes), making them well-suited for standby and peaking purposes.

Combustion turbines are more costly to run per megawatt produced than are the steam generating plants since they burn more expensive fuel. Open-cycle design requires no cooling water. Gas turbines use high-quality fuels, so their emissions are low.

Most gas turbine units are smaller (15-100 MW) than steam and hydroelectric powered units. However, some gas turbines are rated up to 125 MW. Larger units are available and are becoming more popular.

The last type of generating unit we discuss is the combined-cycle unit.

## **Principles of Operation—Combined-Cycle Units**

The combined-cycle unit is not a different technology, but a combination of steam units and gas turbines. In a typical combined-cycle unit, power is generated in the following sequence:

- One or more gas turbines operate as previously described except that exhaust gases are NOT discharged into the atmosphere.
- The turbine exhaust gases exit into a boiler, called a Heat Recovery Steam Generator, where the exhaust heat is used to convert water to steam.
- The steam drives a separate steam turbine to generate additional electricity. Efficiency is dramatically increased since this power is generated without consumption of additional fuel.
- Typically, each gas-turbine generator and each steam-turbine generator are connected to the power grid through independent unit circuit breakers.

Combined-cycle plants combine some of the best features of combustion gas turbines and steam units:

- Like gas turbines, the gas turbine portions of combined-cycle units start up quickly and respond rapidly to changes in power demand. The steam generator portions take longer to bring into use.
- New technology combined-cycle plants run at 50 percent thermal efficiency and higher, which is almost the efficiency of simple-cycle steam generating plants. We discuss efficiency in more detail later in this module.

Beginning in about 2000, combined cycle plants began proliferating across the WECC region and presently constitute 75-80 percent of all new generation capacity being installed. Along with increased efficiency, other factors such as lower capital costs, shorter construction and installation time (generally two years compared to five years for the typical coal-fired plant), and the use of environmentally acceptable natural gas to reduce emissions have all contributed to combined-cycle units being the overwhelming choice of plan developers in the new century.

Now that we understand how different types of generating units operate, let's examine some operating capabilities of generating units.

## **Principles of Operation—Wind Turbines**

Wind is a form of solar energy. Winds are caused by the uneven heating of the atmosphere by the sun, the irregularities of the Earth's surface, and rotation of the Earth. Wind flow patterns are modified by the Earth's terrain, bodies of water, and vegetation. Humans use this wind flow, or motion energy, for many purposes: sailing, flying a kite, and even generating electricity.

The terms wind energy or wind power describe the process by which the wind is used to generate mechanical power or electricity. Wind turbines convert the kinetic energy in the wind into mechanical power. This mechanical power can be used for specific tasks (such as grinding grain or pumping water) or a generator can convert this mechanical power into electricity.

So how do wind turbines make electricity? Simply stated, a wind turbine works the opposite of a fan. Instead of using electricity to make wind, like a fan, wind turbines use wind to make electricity.

- The wind turns the blades
- The blades spin a shaft
- The shaft connects to a generator and makes electricity.

We will take a look inside a wind turbine to see the various parts.

This aerial view of a wind power plant shows how a group of wind turbines can make electricity for the utility grid. The electricity is sent through transmission and distribution lines to homes, businesses, schools, and so on.

**Figure 4.12: Wind Turbine**

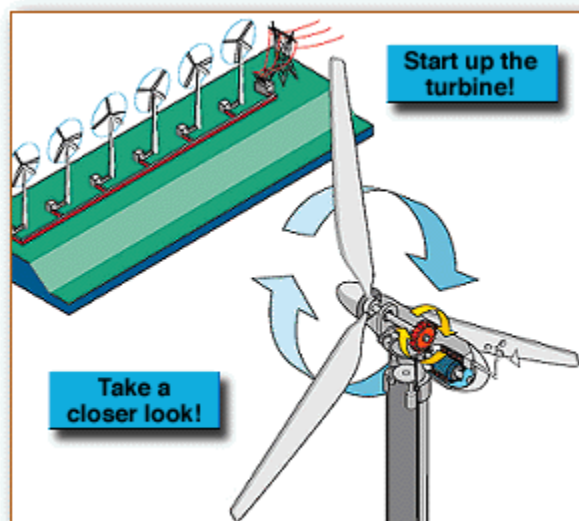

### ***Types of Wind Turbines***

Modern wind turbines fall into two basic groups: the horizontal-axis variety, as shown in the picture above, and the vertical-axis design, which is the eggbeater-style Darrieus model, named after its French inventor.

Horizontal-axis wind turbines typically either have two or three blades. These three-bladed wind turbines are operated "upwind," with the blades facing into the wind.

### ***Sizes of Wind Turbines***

Utility-scale turbines range in size from 100 kilowatts to as large as several megawatts. Larger turbines are grouped together into wind farms that provide bulk power to the electrical grid.

Single small turbines, below 100 kilowatts, are used for homes, telecommunications dishes, or water pumping. Small turbines are sometimes used in connection with diesel generators, batteries, and photovoltaic systems. These systems are called hybrid wind systems and are typically used in remote, off-grid locations, where a connection to the utility grid is not available.

## Inside the Wind Turbine

Figure 4.13: Inside the Wind Turbine

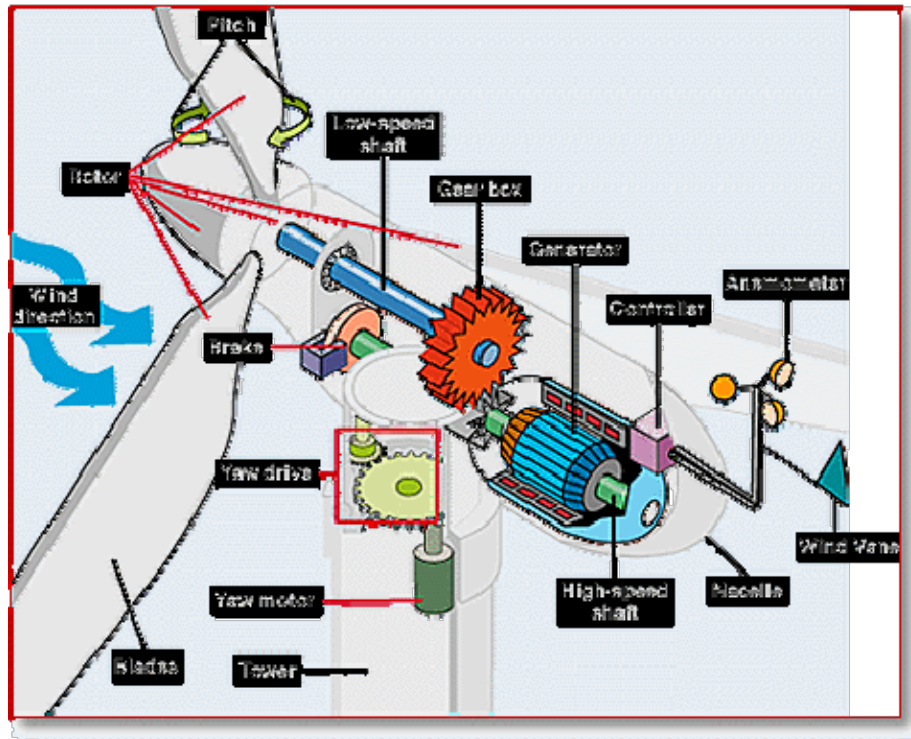

### 1. Anemometer:

Measures the wind speed and transmits wind speed data to the controller.

### 2. Blades:

Most turbines have either two or three blades. Wind blowing over the blades causes them to "lift" and rotate.

### 3. Brake:

A disc brake, which can be applied mechanically, electrically, or hydraulically to stop the rotor in emergencies.

### 4. Controller:

The controller starts up the machine at wind speeds of about eight to 16 miles per hour (mph) and shuts off the machine at about 55 mph. Turbines do not operate at wind speeds above about 55 mph because they might be damaged by the high winds.

### 5. Gear box:

Gears connect the low-speed shaft to the high-speed shaft and increase the rotational speeds from about 30 to 60 rotations per minute (rpm) to about 1000 to 1800 rpm, the rotational speed required by most generators to produce electricity. The gear box is a costly (and heavy) part of the wind

turbine and engineers are exploring "direct-drive" generators that operate at lower rotational speeds and don't need gear boxes.

**6. Generator:**

Usually an off-the-shelf induction generator that produces 60-cycle AC electricity.

**7. High-speed shaft:**

Drives the generator.

**8. Low-speed shaft:**

The rotor turns the low-speed shaft at about 30 to 60 rotations per minute.

**9. Nacelle:**

The nacelle sits atop the tower and contains the gear box, low- and high-speed shafts, generator, controller, and brake. Some nacelles are large enough for a helicopter to land on.

**10. Pitch:**

Blades are turned, or pitched, out of the wind to control the rotor speed and keep the rotor from turning in winds that are too high or too low to produce electricity.

**11. Rotor:**

The blades and the hub together are called the rotor.

**12. Tower:**

Towers are made from tubular steel (shown in the figure above), concrete, or steel lattice. Because wind speed increases with height, taller towers enable turbines to capture more energy and generate more electricity.

**13. Wind direction:**

The figure above shows an "upwind" turbine, so-called because it operates facing into the wind. Other turbines are designed to run "downwind," facing away from the wind.

**14. Wind vane:**

Measures wind direction and communicates with the yaw drive to orient the turbine properly with respect to the wind.

**15. Yaw drive:**

As upwind turbines face into the wind; the yaw drive is used to keep the rotor facing into the wind as the wind direction changes. Downwind turbines don't require a yaw drive, the wind blows the rotor downwind.

**16. Yaw motor:**

Powers the yaw drive.

## ***Advantages and Disadvantages of Wind Energy***

Wind energy offers many advantages, which explains why it's the fastest-growing energy source in the world. Research efforts are aimed at addressing the challenges to promote greater use of wind energy.

### ***Advantages***

Since wind energy is fueled by the wind, it is a clean fuel source. Wind energy does not pollute the air like power plants that rely on combustion of fossil fuels, such as coal or natural gas. Wind turbines do not produce atmospheric emissions that cause acid rain or greenhouse gasses.

Wind energy is a domestic source of energy, produced in the United States. The nation's wind supply is abundant.

Wind energy relies on the renewable power of the wind, which cannot be used up. Wind is actually a form of solar energy; winds are caused by the heating of the atmosphere by the sun, the rotation of the Earth, and the Earth's surface irregularities.

Wind energy is one of the lowest-priced renewable energy technologies available today, costing between four and six cents per kilowatt-hour, depending on the wind resource and project financing of the particular project.

Wind turbines can be built on farms or ranches, thus benefiting the economy in rural areas where most of the best wind sites are found. Farmers and ranchers can continue to work the land because the wind turbines use only a fraction of the space available. Wind power plant owners make rent payments to the farmer or rancher for the use of the land.

### ***Disadvantages***

Wind power must compete with conventional generation sources on a cost basis. Depending on how energetic a wind site is, the wind farm may or may not be cost competitive. Even though the cost of wind power has decreased dramatically in the past 10 years, the technology requires a higher initial investment than fossil-fueled generators.

The major challenge to using wind as a source of power is that the wind is intermittent and it does not always blow when electricity is needed. Wind energy cannot be stored (unless batteries are used); and not all winds can be harnessed to meet the timing of electricity demands.

Good wind sites are often located in remote locations, far from cities where the electricity is needed.

Wind resource development may compete with other uses for the land and those alternative uses may be more highly valued than electricity generation. Although wind power plants have relatively little impact on the environment compared to other conventional power plants, there is some concern over the noise produced by the rotor blades, aesthetic (visual) impacts, and sometimes birds have been killed by flying into the rotors. Most of these problems have been resolved or greatly reduced through technological development or by properly siting wind plants.

### ***History of Wind Energy***

Since early recorded history, people have been harnessing the energy of the wind. Wind energy propelled boats along the Nile River as early as 5000 B.C. By 200 B.C., simple windmills in China were pumping water, while vertical-axis windmills with woven-reed sails were grinding grain in Persia and the Middle East.

New ways of using the energy of the wind eventually spread around the world. By the 11th century, people in the Middle East were using windmills extensively for food production; returning merchants and crusaders carried this idea back to Europe. The Dutch refined the windmill and adapted it for draining lakes and marshes in the Rhine River Delta. When settlers took this technology to the New World in the late 19th century, they began using windmills to pump water for farms and ranches, and later, to generate electricity for homes and industry.

Industrialization, first in Europe and later in America, led to a gradual decline in the use of windmills. The steam engine replaced European water-pumping windmills. In the 1930s, the Rural Electrification Administration's programs brought inexpensive electric power to most rural areas in the United States.

However, industrialization also sparked the development of larger windmills to generate electricity. Commonly called wind turbines, these machines appeared in Denmark as early as 1890. In the 1940s the largest wind turbine of the time began operating on a Vermont hilltop known as Grandpa's Knob. This turbine, rated at 1.25 megawatts in winds of about 30 mph, fed electric power to the local utility network for several months during World War II.

The popularity of using the energy in the wind has always fluctuated with the price of fossil fuels. When fuel prices fell after World War II, interest in wind turbines waned. But when the price of oil skyrocketed in the 1970s, so did worldwide interest in wind turbine generators.

The wind turbine technology research and development that followed the oil embargoes of the 1970s refined old ideas and introduced new ways of converting wind energy into useful power. Many of these approaches have been demonstrated in "wind farms" or wind power plants — groups of turbines that feed electricity into the utility grid — in the United States and Europe.

## Wind Energy Resource Potential

The United States has enough wind resources to generate electricity for every home and business in the nation. But not all areas are suitable for wind energy development. The Wind Energy Program measures the potential wind energy resources of areas across the United States in order to identify ideal areas for project development.

### ***Wind Energy Resource Potential and Wind Energy Projects***

One of the first steps to developing a wind energy project is to assess the area's wind resources and estimate the available energy. Correct estimation of the energy available from the wind can make or break the economics of a project.

To help the wind industry identify the areas best suited for development, the Wind Energy Program works with the National Renewable Energy Laboratory and other organizations to measure, characterize, and map wind resources 50 meters (m) to 100 m above ground.

The following map shows the annual average wind power estimates at 50 m above ground. It combines high and low resolution datasets that have been screened to eliminate land-based areas unlikely to be developed due to land use or environmental issues. In many states, the wind resource has been visually enhanced to better show the distribution on ridge crests and other features.

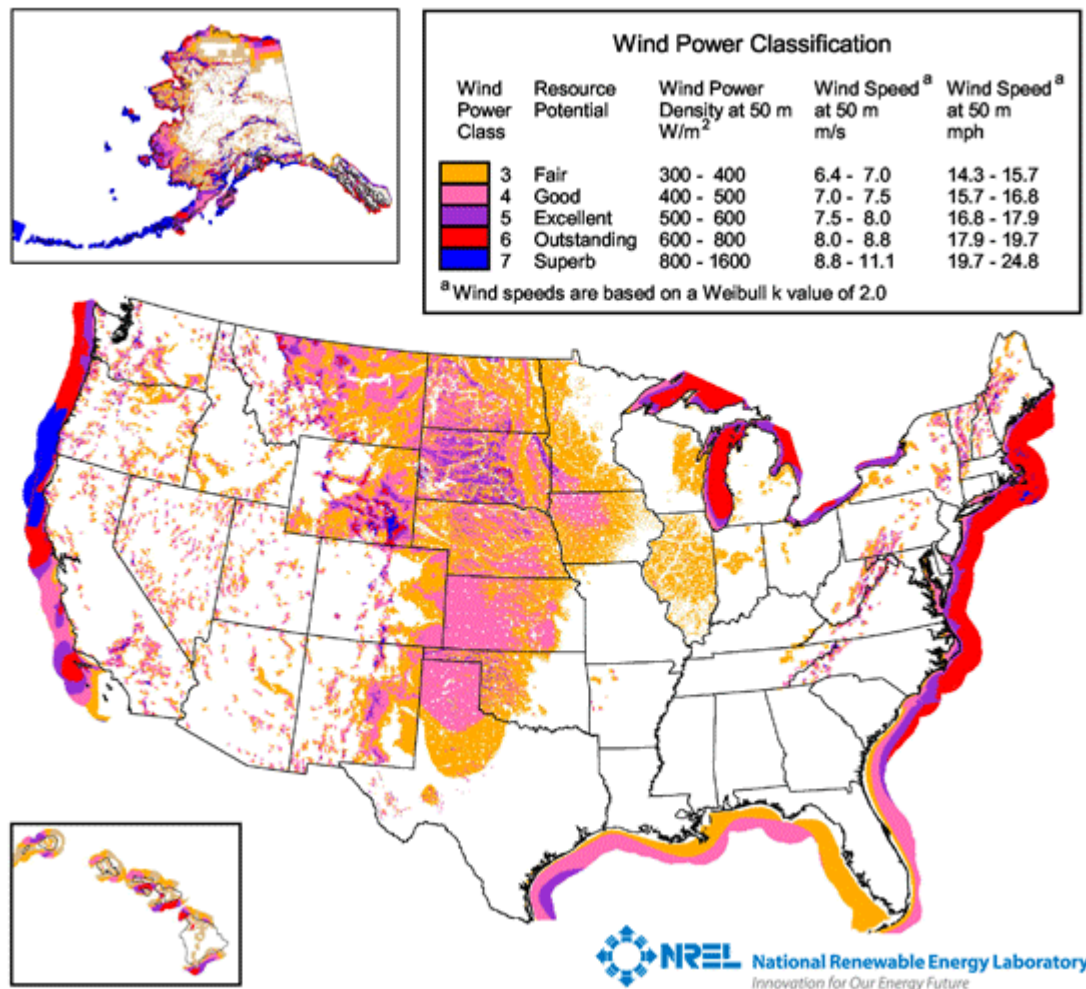

Estimates of the wind resource are expressed in wind power classes ranging from Class 1 to Class 7, with each class representing a range of mean wind power density or equivalent mean speed at specified heights above the ground. This map does not show Classes 1 and 2 as Class 2 areas are marginal and Class 1 areas are unsuitable for utility-scale wind energy development.

## Section 4-4: Generating Unit Operating Characteristics

Each type of generating unit has different operating characteristics. We discuss:

- Efficiency
- Unit Capability and Minimum Load
- Response Rate

## Efficiency

### Definition: Efficiency

**Efficiency** is the measure of how much output is received for a given amount of input. Some utilities measure the generator output at the terminals (gross output). Other utilities measure generator output at the step-up transformer for the station (net output). For power generating units, the output is the megawatts of electrical power and the input is barrels of oil, tons of coal, cubic feet of water, or other fuel resources; depending on the type of plant.

- Higher efficiency means that we are getting more output from a given amount of input.
- Lower efficiency means that we are getting less output — or our losses are higher — from a given amount of input.

Let's look at the efficiency of different types of generating units.

### **Steam Generating Units**

For fossil-fired units, the benefits of higher efficiency are obvious. Higher efficiency means you burn less fuel to get the desired megawatts of output. Burning less fuel while supplying the same customer demand translates directly into increased savings. Given that fuel purchases are the highest expense for most utilities, amounting to hundreds of millions of dollars annually, the dollar savings that can be achieved by operating units in the most efficient manner can be substantial.

### Definition: Heat Rate

Efficiency for steam-powered generating units is commonly expressed as a **heat rate**. Heat rate is the amount of heat measured in BTUs (British Thermal Units) required to produce a kilowatt hour of electrical output.

More efficient units have a lower heat rate than less efficient units, because more efficient units require less heat input to produce a given amount of electrical output.

The United States' most efficient fossil-fired units have a heat rate of around 9,800 BTU/kWh. The average efficiency is about 10,500 BTU/kWh.

Steam generating units are generally designed to have their lowest heat rate when operating at close to maximum load. Ideally, this optimal heat rate is maintained at all loads. In reality, the heat rate decreases as loading increases, up to the rating of the generating unit. The heat rate then begins to increase (the unit becomes less efficient) as loading increases past its rating, to the maximum output of the unit.

## ***Hydroelectric Generating Units***

At first glance, efficiency does not appear to be as vital an issue for hydroelectric generating units as it is for fossil-fired generating units. This is because water supplies the input power to hydroelectric units. Water essentially does not cost anything. So, who cares if you have to use a bit more water to obtain a particular output?

In reality, water is a limited resource and hydroelectric plant efficiency is an important issue. In drought-stricken areas, the small streams and lakes that normally feed the reservoirs used by hydroelectric plants may be low. This limits the amount of water available for use by the plant. Water used by pumped storage stations is not “free.” The price of the water is the cost of the energy it takes to pump the water to the upper reservoir. In these cases, it is important to get as much energy as possible out of every drop of water.

Like steam units, hydroelectric units' efficiency initially increase as load on the plant is increased. Efficiency continues to increase proportionately until about 30-50 percent load, when efficiency begins to increase more slowly. As load continues to increase, a point (which varies) is reached where efficiency begins to decrease as load is increased.

We now discuss another operating capability, the unit's capability, and its minimum load.

## **Unit Capability and Minimum Load**

### **Definition: Unit Capability**

***Unit capability*** refers to the maximum possible megawatt output that the generating unit can safely produce. Going any higher would require more steam than the steam generator can furnish or more water than can flow through the penstocks and wicket gates. Unit capability is dependent on the design of the boiler, turbine, and generator; and on the coolant conditions, such as the ambient air temperature and the hydrogen pressure in the generator cooling system.

### **Definition: Minimum Load**

***Minimum load*** is the smallest amount of generation that a unit can sustain for an extended period. At minimum load, unit efficiency is much lower than at the rated load.

## ***Steam Generating Units***

For steam generating units, a unit's rating, which is the unit's most efficient operating point, is generally slightly lower than the unit's maximum capability.

In fossil-fired generating units, we encounter difficulties in maintaining stable fuel combustion at low loads.

### ***Hydroelectric Generating Units***

#### **Definition: Cavitation**

Hydroelectric units may experience a problem called **cavitation**, which can seriously damage the turbine. Basically, cavitation is the formation of water vapor bubbles that can implode (burst inward) or collapse, resulting in turbulence that can cause "pitting" in metallic surfaces. Cavitation may be caused by low water levels in the tailrace.

The next generating unit capability we discuss is the response rate of the unit.

### **Response Rate**

#### **Definition: Response Rate**

**Response rate** is the rate of load change that a generating unit can achieve for normal operating purposes in MW/min. Steam generating plants must change load relatively slowly, compared with some other types of units. This is because the boiler or steam generator responds fairly slowly to changing load demands. Steam generating units must be started up slowly and they must pause frequently during start-up to allow components to gradually rise to their rated temperature. When on-line, changes in unit loading must be applied relatively slowly to maintain stability of the unit controls. Newer units are designed to respond faster.

As a result, steam-generating units are generally held at a steady load or regulated within limits set at the plant. Once a steam unit is on-line, it is usually kept on-line as much as practical to avoid unnecessary and frequent unit start-ups and shutdowns.

Combustion turbines are generally much simpler, and usually smaller, than steam generating units. They are brought on-line and shut down much more quickly than steam generating units. Combustion turbines also can change load rapidly on request.

The characteristics of combustion units make them best suited for use as "peaking" units. During daily peak-load periods when load demand may be high for a short period of time (a few hours), it is common practice to start peaking units, run them for a few hours until the peak load period ends, and then shut these units down.

#### **Definition: Regulating Units**

Hydroelectric units can respond rapidly to load changes. Coupled with the fact that these units are on-line as much as possible due to their low operating cost, utilities that have hydroelectric units usually use them as ***regulating units***. Regulating units adjust their outputs up or down as power system load increases and decreases or energy schedules change.

**Conclusion:** This concludes the module on principles of power generation. We discussed the basics of generators and turbines and examine the operating principles of various types of units. You should use this knowledge to review the generating units that your utility owns or operates.

**Module 4 Principles of Power Generation  
Question Set**

**Module 4**  
**Principles of Power Generation**  
**Question Set**

**4.1** Circle the correct response:

**(a)** The stator on an AC generator is **stationary/rotary**.

**(b)** The rotor on an AC generator is **stationary/rotary**.

**4.2** Provide the following information about excitation systems:

**(a)** Describe the operation of an excitation system.

**(b)** List the two control functions that an excitation system can provide.

- 4.3** Given the following characteristic curve, determine if the operating conditions are acceptable or not acceptable:

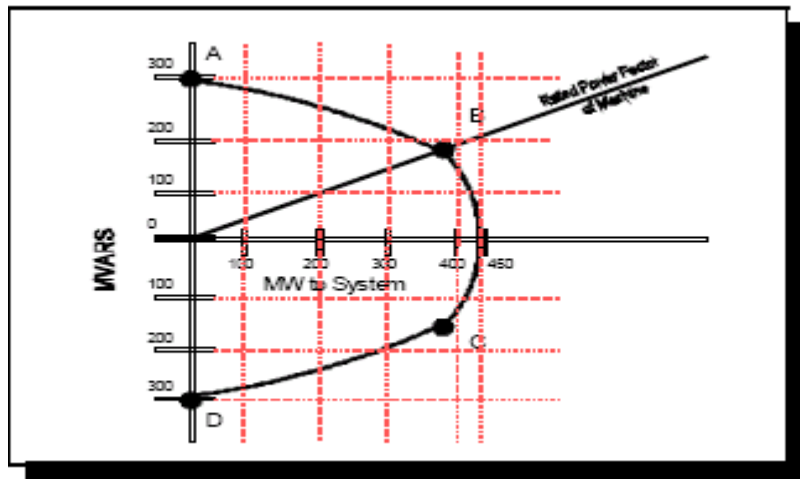

- (a) An operating point of 425 MW and supplying 300 Mvars.
- (b) An operating point of 375 MW and absorbing 150 Mvars.
- (c) An operating point of 350 MW and absorbing 300 Mvars.

- 4.4** Answer the following questions about generator electrical characteristics:

- (a) Is a generator over-excited or under-excited if it is absorbing VARS?
- (b) State one undesirable effect of a generator operating at an extreme leading power factor.

**4.5** List three types of steam generating units.

**4.6** Provide the following information about fossil-fired steam units:

**(a)** Describe the difference between a drum-type and a once-through boiler.

**(b)** Each of the events listed below is a step in the steam cycle. Place the process steps in the correct order.

1. \_\_\_\_ The steam flows to the turbine via the main steam line where nozzles direct the steam flow against the steam turbine blades.
2. \_\_\_\_ Cool, circulating water flowing through tubes condenses the steam. This steam is now called condensate.
3. \_\_\_\_ Fuel burns in the furnace, producing heat.
4. \_\_\_\_ The condensate pump pumps the condensate to a feedwater heater that begins to reheat the condensate.

5. \_\_\_\_ The heat boils water in the boiler and changes the water to steam.
6. \_\_\_\_ The feedwater pump adds pressure to the condensate to force the water back to the boiler.
7. \_\_\_\_ The steam used to turn the turbine flows into the condenser or directly to the feedwater heater.

**4.7** Answer the following questions about nuclear units:

**(a)** How is a nuclear fission process controlled?

**(b)** Describe the difference between a boiling water reactor and a pressurized water reactor.

**4.8** Provide the following information about hydroelectric generating units:

**(a)** List two factors that determine the amount of power generated by a hydroelectric generator.

**(b)** List the two types of hydroelectric stations we discussed in the module.

**4.9** How does a combustion turbine differ from a steam turbine?

**4.10** Match the operating capability in Column 1 with its definition in Column 2.

<b>Column 1</b>	<b>Column 2</b>
_____ Efficiency	A. The maximum megawatt output that the generating unit can safely produce.
_____ Unit Capability	B. The measure of how much useable output is produced for a given amount of input.
_____ Response Rate	C. The amount of heat measured in BTUs required to produce a kilowatt hour of electrical output.
_____ Heat Rate	D. The smallest amount of generation that a unit can produce for an extended period of time.
_____ Minimum Load	E. The rate of load change that a generating unit can achieve for normal operating purposes in MW/min.



## **Module 5: Substation Overview**

This page intentionally left blank.

## Module 5: Substation Overview

### Table of Contents

<b>Substation Overview .....</b>	<b>5-5</b>
<b>Section 5-1: Purpose of Substations .....</b>	<b>5-5</b>
<b>Section 5-2: Substation Equipment.....</b>	<b>5-7</b>
Switchgear Equipment .....	5-7
Circuit Breakers .....	5-8
Operating Principle .....	5-8
Types of Circuit Breakers .....	5-11
Ratings and Operating Considerations .....	5-18
Load Break Switches.....	5-19
Disconnect Switches .....	5-20
Capacitors .....	5-21
Reactors.....	5-23
Synchronous Condensers .....	5-25
Lightning Arresters .....	5-26
Wave Traps.....	5-28
<b>Section 5-3: Substation Control House .....</b>	<b>5-30</b>
Control Panels.....	5-30
Other Equipment .....	5-33
Station Battery.....	5-33
Energy Management System/Supervisory Control and Data Acquisition (EMS/SCADA) System Remote Terminal Units .....	5-34
Programmable Logic Controller/Human-Machine Interface .....	5-34
Fault and Sequence-of-Event Recorders .....	5-34
<b>Section 5-4: Substation Bus Configurations .....</b>	<b>5-35</b>
Single Bus .....	5-36
Main and Transfer Bus .....	5-37
Ring Bus.....	5-38
Breaker-and-a-Half Arrangement .....	5-39
Double Bus-Double Breaker Arrangement.....	5-40
<b>Module 5 Substation Overview Question Set.....</b>	<b>5-41</b>

## Module 5: Substation Overview

### Table of Figures

Figure 5.1: High-Voltage Circuit Breaker .....	5-9
Figure 5.2: 46kV Oil Circuit Breaker .....	5-12
Figure 5.3: Air Circuit Breaker .....	5-13
Figure 5.4: 345kV Air Blast Circuit Breaker .....	5-14
Figure 5.5: 230kV Gas Blast Circuit Breaker .....	5-15
Figure 5.6: 115kV Gas Puffer Circuit Breaker .....	5-16
Figure 5.7: 34.5kV Vacuum Circuit Breaker .....	5-17
Figure 5.8: Capacitor .....	5-21
Figure 5.9: High-Voltage Capacitor Bank .....	5-23
Figure 5.10: High-Voltage Line Reactor (500kV) .....	5-24
Figure 5.11: Low-Voltage Tertiary Reactor (13.8kV) .....	5-25
Figure 5.12: Synchronous Condenser .....	5-26
Figure 5.13: Diagram of a Lightning Arrester .....	5-27
Figure 5.14: High-Voltage Lightning Arrester .....	5-27
Figure 5.15: High-Voltage Lightning Arrester on High-Voltage Bus .....	5-28
Figure 5.16: Wave Trap .....	5-29
Figure 5.16a: Upper Half of Transformer Relay Panel .....	5-31
Figure 5.16b: Bottom half of Transformer Relay Panel .....	5-31
Figure 5.17: Transmission Line Relay Panel .....	5-32
Figure 5.18: Substation Battery Bank .....	5-33
Figure 5.19: Single Bus .....	5-36
Figure 5.20: Main and Transfer Bus .....	5-37
Figure 5.21: Ring Bus .....	5-38
Figure 5.22: Breaker-and-a- Half Arrangement .....	5-39
Figure 5.23: Double Bus - Double Breaker Arrangement .....	5-40

## Substation Overview

### Module Overview

The **Substation Overview** module presents the following topics:

- Purpose of Substations
- Substation Equipment
- Substation Control House
- Substation Bus Configurations

First, we discuss what a substation is and then we examine some equipment found in a substation.

### Section 5-1: Purpose of Substations

#### Definition: Substation

In general, a substation is a power system facility that contains power system components such as:

- circuit breakers and other switchgear
- transformers
- reactors
- capacitors

A substation usually includes a control house that contains equipment such as:

- protective relays
- meters
- alarm annunciators
- communications equipment

We discuss control house equipment in more detail later in this module.

Power lines originate and terminate at substations. Overhead wires or underground cables may carry power to or from substations. Substations can be either indoors or outdoors, or they can have a combination of both indoor and outdoor equipment.

- An indoor substation houses all electrical equipment within the walls of a building. Indoor substations may either be entirely underground or look similar to other buildings in the neighborhoods that they serve.
- Outdoor substations have the same equipment as indoor substations but the equipment is located outside where it is exposed to natural elements, rather than in a building. The equipment is usually enclosed within a fence.

### **Definition: Ground Mat**

Substations usually include a ground mat. A **ground mat** is a system of bare conductors, on or below the surface, connected to a ground to provide protection from high voltages.

You may recall reading in **Module 3: Power System Overview**, that there are different types of substations, including transmission substations, subtransmission substations, and distribution substations. In this module we discuss aspects common to all the types.

One purpose of a substation is to contain the equipment for changing electric energy from one voltage to another. Substations also enable one or more of the following functions to be accomplished:

- Switching operations
  - Substations connect or disconnect elements of the power system, using circuit breakers and/or switches.
- Reactive power compensation
  - Utilities install synchronous condensers, shunt reactors, shunt capacitors, and static Var compensators at substations to control voltage.
  - Utilities install series capacitors at substations to reduce line reactance.

Now that we understand the purpose of a substation, let's examine some of the equipment found in a substation.

## Section 5-2: Substation Equipment

In this section we describe the function and operating principles of the following power system components:

- Switchgear Equipment
- Capacitors
- Reactors
- Ground Switches
- Lightning Arresters
- Wave Traps

A transformer is another power system component found in a substation. We discuss transformers in **Module 6: Transformers**.

### Switchgear Equipment

#### Definition: Switchgear

**Switchgear** is a general term given to switching and interrupting devices. Switchgear equipment is commonly contained in metal-enclosed units. However, at higher voltages, the equipment may or may not be in metal enclosed units.

Switchgear equipment performs two separate functions.

- Under normal conditions, switchgear equipment enables routine switching operations to occur.  
For example: Switchgear equipment disconnects and isolates a piece of equipment so maintenance work can be performed.
- Under abnormal conditions, switchgear equipment automatically disconnects faulted equipment from the rest of the power system as soon as possible, in order to minimize damage. Under these conditions, switchgear equipment performs a protective function.

All switchgear operates by pulling apart electric conductors (contacts). As the contacts are drawn apart while power is flowing through the device, an arc forms between the contacts. The arc is drawn out in length as the contacts open. To interrupt current flow, the arc must be extinguished with a dielectric substance, such as air, oil, or sulfur hexafluoride (SF<sub>6</sub>).

We discuss the following types of switchgear equipment:

- Circuit Breakers
- Load Break Switches
- Disconnect Switches

We examine the function and operating principle for each of these.

### ***Circuit Breakers***

Circuit breakers disconnect circuits or equipment from the power system. A circuit breaker's primary function is to interrupt current flow under load or fault conditions.

Circuit breakers rapidly isolate faulted portions of the power system. They also provide a means to carry out routine switching operations, such as disconnecting a device to conduct maintenance.

### ***Operating Principle***

To interrupt the current, the circuit breaker must trip. Let's examine the mechanics involved in tripping circuit breakers under fault conditions.

- When a fault occurs, relays sense the fault and initiate the opening of the circuit breakers related to the faulted equipment by energizing the circuit breakers' trip coils. **Module 8: System Protection**, presents the details on the operation of relays.
- The circuit breakers open for a pre-determined time period based on the reclosing relays settings. After the pre-determined time period, the reclosing relays signal the close coils to close the circuit breakers. The time delay is sufficient to allow the arc to extinguish.
- If the fault still exists after reclosing (e.g., if it is a permanent fault, such as a conductor touching the ground), then the relays signal the circuit breakers' trip coils to open the circuit breakers again, this time permanently.

**Note:** *Not all circuit relay schemes include reclosing relays.*

Now, let's examine what is happening inside the circuit breaker.

**Figure 5.1: High-Voltage Circuit Breaker**

Figure 5.1 shows a circuit breaker in the open position. The dotted lines for the lift mechanism (at the top of the tank) show the location of the lift rod when the breaker is in the closed position. In the closed position, the cross head touches the contacts to complete the circuit.

1. the current flows in one bushing
2. down through the contact
3. across the cross head
4. up through the other contact
5. out the other bushing

When the trip coil trips the circuit breaker, the following events occur:

The lift rod begins to lower the cross head. This creates an arc from each of the contacts to the cross head. Interruption of the arc stops the flow of current.

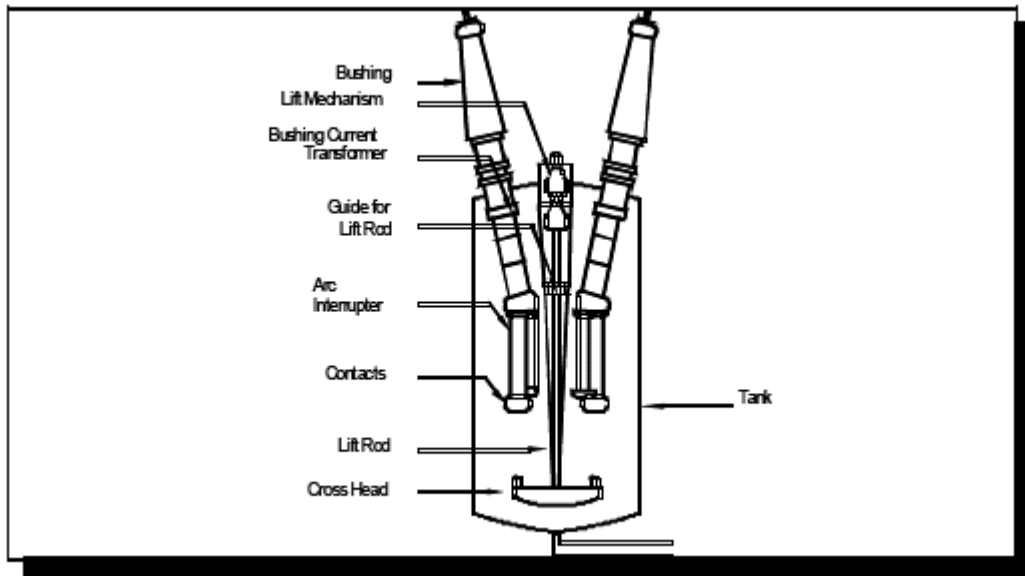
We know from **Module 2: Fundamentals of Electricity**, that alternating current passes through zero twice per cycle. In the circuit breaker, when alternating current passes through zero, the arc temporarily extinguishes.

**Definition: Restriking**

The insulating medium (oil, air, etc.) is still hot from the original arc and includes ionized molecules that form a conducting path. Therefore, when the voltage increases again, the arc usually re-ignites in an action called **restriking**.

During restriking, the cross head continues to separate from the contacts. This process repeats itself twice per cycle until the cross head is far enough from the contacts that the arc cannot re-establish itself. At this point, the flow of current is completely interrupted.

**Definition: Operator**

Once the fault has been cleared, the circuit breaker can be closed. The device used to close a circuit breaker is called **an operator**. The methods of closing a circuit breaker are:

- An energized solenoid drives the breaker into the closed position.
- A motor compresses a closing spring that closes the breaker.
- Compressed air drives a piston that drives the breaker to the closed position. If pressure is lost, only the pneumatic operator closing the breaker is affected; the circuit breaker's tripping or interrupting capability is not affected.

Some circuit breakers are equipped with a switch to manually trip in the event of a failure in the electrical controls. Such switches commonly need to be manually reset before the affected circuit breaker can be closed again.

A common problem that results in failure to trip or close a circuit breaker is an open-circuit in the trip coil itself or in the DC wiring leading to the trip coil.

To detect an open-circuit condition before it is necessary to trip the breaker, manufacturers connect a lamp on the circuit breaker's control panel in series with the trip coil and its associated wiring.

- If the lamp is on, the wiring and coil are intact.
- If the lamp is off, the wiring and coils are not intact and the circuit breaker may not operate when called on to trip.

We know that one function of a circuit breaker is to interrupt fault current. Tripping the breaker to interrupt fault current creates an internal arc that produces very high temperatures.

The two most common methods of extinguishing the arc are:

- increasing the arc's length
- cooling the insulating medium around the arc (de-ionizes the medium)

Circuit breakers use many different insulating media to interrupt the arc. The most common insulating media include:

- air
- oil
- SF<sub>6</sub>
- vacuum

Let's examine some common types of circuit breakers.

### ***Types of Circuit Breakers***

There are several different circuit breaker types, including:

- oil circuit breakers
- air circuit breakers
- air blast circuit breakers
- gas blast circuit breakers
- gas puffer circuit breakers
- vacuum circuit breakers

Each type of circuit breaker indicates a method used to interrupt the arc within the breaker.

## ***Oil Circuit Breakers***

In oil circuit breakers (OCBs), forcing fresh oil into the arc's path cools, lengthens, and eventually extinguishes the arc. For OCBs, arcing carbonizes the insulating oil and over time, carbonization decreases the insulating capability. Therefore, utilities periodically filter or replace the oil.

- At lower voltages, one OCB encloses all three phases.
- At higher voltages, which require greater interrupting capacity, each phase may use a separate OCB.

**Figure 5.2: 46kV Oil Circuit Breaker**



## ***Air Circuit Breakers***

Air circuit breakers (ACBs) magnetically force the arc into an arc chute to elongate, cool, and extinguish the arc. An ACB typically includes a ***puffer***. The puffer directs a blast of air at the arc to assist in extinguishing the arc.

**Figure 5.3: Air Circuit Breaker**



## ***Air Blast Circuit Breakers***

In air blast circuit breakers (ABCB), compressed air opens and closes the contacts. A blast of dry air extinguishes the arc. If the air pressure drops too low, an ABCB will not operate because of possible damage to the breaker.

**Figure 5.4: 345kV Air Blast Circuit Breaker**

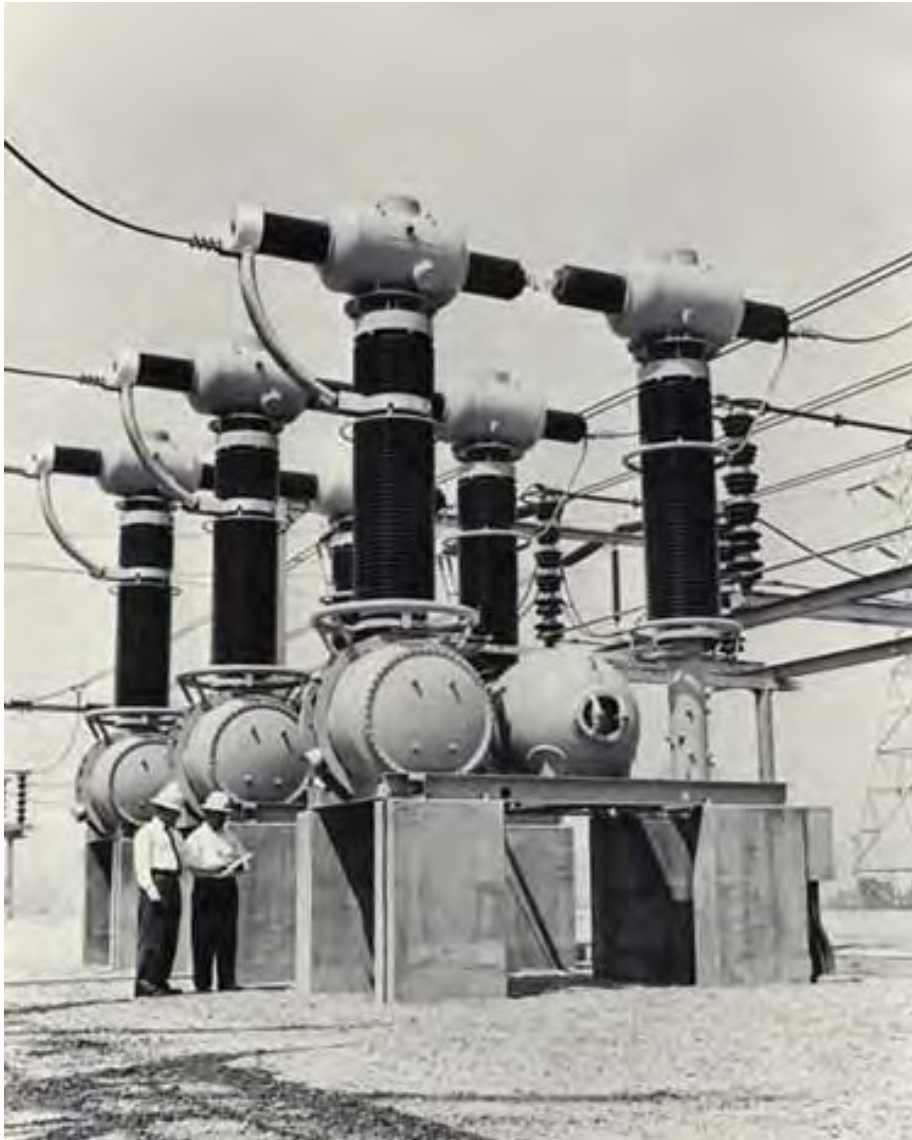

## ***Gas Blast Circuit Breakers***

Similar to ABCBs, gas blast circuit breakers (GBCBs) direct a short blast of high pressure gas at each contact to extinguish the arc. GBCBs use SF<sub>6</sub> as the arc interrupting and insulating medium.

**Figure 5.5: 230kV Gas Blast Circuit Breaker**



## ***Gas Puffer Circuit Breakers***

Gas puffer circuit breakers (GPCBs) use a puff of SF<sub>6</sub> gas to extinguish the arc. Unlike GBCBs, GPCBs do not require a compressor. Manufacturers mount a piston and cylinder assembly on the moving contact. As the contact opens, the cylinder compresses the SF<sub>6</sub> gas and applies a high pressure burst of gas to the arc.

**Figure 5.6: 115kV Gas Puffer Circuit Breaker**



## ***Vacuum Circuit Breakers***

In vacuum circuit breakers, the insulating medium is a high vacuum. The vacuum interrupters use a moving contact and a stationary contact both housed in a sealed, metal envelope. An actuator outside the envelope triggers the movement of the moveable contact. Inside the envelope, a metal or glass condensing shield surrounds the contacts to collect the evaporated contact material that is released when an arc is drawn. Since a vacuum contains no conducting material, the arc is immediately extinguished.

**Figure 5.7: 34.5kV Vacuum Circuit Breaker**



Now let's examine the ratings and operating considerations of circuit breakers.

## ***Ratings and Operating Considerations***

The operating voltage and the amount of current the circuit breaker can interrupt determine a circuit breaker's rating. A circuit breaker is rated based on the following parameters:

- maximum voltage
- continuous current
- interrupting current capabilities

For example:

A circuit breaker may be rated as 765 kV maximum voltage, 3 kA continuous current, and current interrupting capability of 63 kA.

### **Definition: Maximum Continuous**

Circuit breakers have a ***maximum continuous current carrying capability***, which is the highest load current that the circuit breaker is designed to carry for extended time periods. Exceeding this rating may result in overheating that could damage the circuit breaker contacts and insulation.

### **Definition: Maximum Interrupting Current**

Circuit breakers are also rated according to the maximum fault current that they are capable of interrupting. This is called ***maximum interrupting current***. Fault currents exceeding the breaker rating may produce arcs with more energy than the circuit breaker can extinguish. In this case, the breaker may fail to interrupt the fault current.

### **Definition: Interrupting Time**

***Interrupting time*** is the period from the instant current begins to flow through the trip coil until the circuit breaker interrupts the fault.

Typical interruptions are measured in cycles and vary in time. On high-voltage transmission lines, interruptions vary from two to eight cycles.

### **Definition: Closing Time**

***Closing time*** is the time it takes to close a breaker from the instant the close coil is energized until current begins to flow through the breaker.

Typical closing times vary from two to 40 cycles.

**Definition: Independent Pole Operation**

***Independent pole operation*** uses a separate mechanism for each breaker phase. Independent pole operation allows the tripping of independent poles (phases) which reduce the possibility of a three-pole stuck breaker for a three-phase fault. It also reduces the impact on the system that occurs when three phases are interrupted. Two types of independent pole operation are:

- single pole
- selective pole

Single pole operation trips one pole for each phase-to-ground fault and trips all poles for all other types of faults.

Selective pole operation clears only the faulted phase or phases for all types of faults.

Another use of independent pole operation is realized by the addition of a Synchronous Control Unit (SCU). The SCU is a microprocessor-based control device that enables synchronized closing or opening of the independent poles of a circuit breaker. For example; when used with a capacitor circuit breaker, the SCU can be programmed to open or close the poles when the respective phases' voltage waveform is at exactly zero, thereby minimizing potentially damaging transient overvoltages caused by capacitor switching operations.

Now let's discuss another piece of switchgear; load break switches.

**Load Break Switches**

Load break switches interrupt normal load current but cannot interrupt fault current. Utilities install load break switches when they need a method for disconnecting a device for scheduled maintenance, but they cannot justify the expense of a circuit breaker.

For example:

A utility may install a load break switch on either side of a transformer. If a fault occurs in the transformer, isolating the fault requires opening the circuit breakers for the line feeding the transformer.

Breaking current with a load break switch forms a long arc through the air. The arc may rise many feet and last several seconds before it stretches out far enough to be cooled and extinguished. During this time, the switch blade moves far from the stationary contact. This prevents the arc from restriking.

A simple example of a load break switch is the light switch on a wall in a home.

The last piece of switchgear equipment we discuss is a high-voltage disconnect switch.

## **Disconnect Switches**

Disconnect switches are not used to interrupt normal load currents except under special conditions. Disconnect switches isolate lines and other equipment, such as transformers or circuit breakers, after circuit breakers or load break switches have interrupted the current. They may interrupt charging currents to the unloaded devices being disconnected.

Disconnect switches can be operated manually, but some may be operated automatically by remote control or by protective relays.

The disconnect switch may be a horizontal- or a vertical-type switch. Breaking current with this device forms an arc in the air. The arc may extend many feet and last several seconds before it stretches far enough to be extinguished. During this time, a blade is moving away from a stationary contact. The blade eventually is moved far enough away from the stationary contact to prevent the arc from restriking.

A special type of high-voltage disconnect switch is the ground switch. Ground switches are disconnect switches that provide a solid ground to a power line or piece of station equipment such as a bank or a bus. The general function of a ground switch is to provide a safety ground.

Ground switches provide a convenient way to apply a safety ground to a de-energized piece of equipment. They protect maintenance personnel from accidental re-energizing of the equipment. They also provide some protection from stored charge in the equipment or the induced charge from nearby energized equipment. This protection is generally considered inadequate, however, and crews use personal grounds at the work site.

A circuit switcher is a type of disconnect switch that has a limited interrupting capability and is used primarily for switching capacitors and reactors. It can also be used to isolate sections of a line.

Now, let's move on and look at another piece of substation equipment, the capacitor.

## Capacitors

A capacitor is a set of metal plates separated by an insulating material, called a dielectric. Capacitors introduce capacitance into a circuit.

**Figure 5.8: Capacitor**

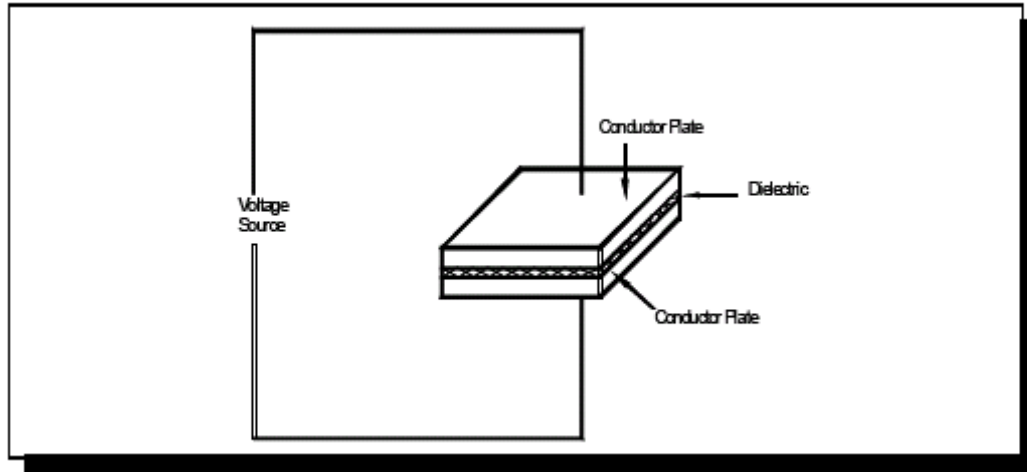

You may recall from reading *Module 2: Fundamentals of Electricity*, that capacitance is the ability to oppose change in voltage by using energy stored in an electrical field.

- Capacitance, measured in farads, increases as the plate area increases.
- The capacitance decreases as the plate spacing increases.

You may also recall from reading *Module 2: Fundamentals of Electricity*, that the Vars flowing over a transmission line or distribution feeder cause voltage drops between the source and the load. The current associated with the Var flow also lowers the circuit's capacity to carry watts and increases the power loss. If there were a way to generate Vars at each load, we could eliminate excessive Var flow.

Generally, utilities use capacitors in banks (groups of capacitors). Since it is not physically or economically practical to generate Vars at each load, utilities install shunt capacitor banks as close to the load as is practical to generate Vars.

Because it takes time to discharge a stored charge from a capacitor, there is usually an enforced minimum time between capacitor switching operations to allow the capacitor to discharge.

Capacitors have many uses on the power system, including:

- Voltage Regulation — Utilities install capacitors to maintain voltage within preset limits by generating Vars.
- Power Factor Correction — Utilities install shunt capacitors on distribution circuits to improve the power factor.
- Inductance Reduction — Utilities install capacitors in series with long high-voltage transmission lines to offset the series inductance. This improves stability and increases power transfer capability. We discuss stability in ***Module 9: Principles of Power System Operation***.
- Measuring Devices for Protection System — Coupling capacitance voltage transformers (CCVTs) are stacks of capacitors and resistors. CCVTs measure voltage on transmission lines 100 kV and greater. We discuss CCVTs in more detail in ***Module 8: System Protection***.
- Communications for Power Line Carrier — Capacitors are ideally suited for coupling high-frequency power line carrier signals to the power line because of the capacitor's low impedance to high-frequency signals. Recall from ***Module 2: Fundamentals of Electricity***, that the magnitude of the impedance of a capacitor is  $1/(2\pi fC)$ , so the higher the frequency, the lower the capacitive reactance (impedance).
- Filters for Undesirable High-Frequency Signals — Capacitors filter out high-frequency signals from the power line voltages. This application is particularly important at high-voltage direct current (HVDC) line converter terminals where the converters create harmonic frequencies.

Utilities install shunt capacitor banks, typically connected in an either grounded or ungrounded Wye (star) configuration, with fuse protection for individual phases, or individual capacitor units, depending on the type of installation.

**Figure 5.9: High-Voltage Capacitor Bank**

The next piece of substation equipment we discuss is the reactor.

## Reactors

A shunt reactor is an inductor (or a coil) connected from conductor to ground. Shunt reactors absorb Vars, producing the opposite effect of shunt capacitors.

Utilities use reactors to perform the following functions:

- **Cancel Effects of Transmission Lines' Shunt Capacitance** — Utilities install shunt reactors at the terminals of long transmission lines to reduce the voltage rise effects of the lines' shunt capacitance. Installing shunt reactors may affect normal switching procedures.
- **Limit Fault Current Magnitude** — Utilities may insert reactors in series with operating bus sections and often insert reactors in series with distribution circuits to limit fault current magnitude. This is particularly useful at substations that are close to generating stations and on major transmission facilities, where fault current magnitude may exceed the circuit breaker's interrupting rating. Utilities also insert reactors in the distribution substation transformer neutral to limit the ground fault current flow.

- Filter for Undesirable High-Frequency Signals — Utilities use reactors in conjunction with capacitors to filter out high-frequency signals from the power line voltages. This application is particularly important at HVDC line converter terminals in filtering the harmonic frequencies created by the converter equipment.
- Voltage Regulation — Utilities use reactors to maintain voltage within preset limits by absorbing Vars.

Shunt reactor banks for high-voltage applications are usually immersed in oil-filled tanks similar to power transformers. The operating considerations identified for transformers also apply to oil-immersed reactor banks. (See to **Module 6: Transformers**, for more information.)

For low-voltage applications (e.g., distribution applications), utilities use dry-type air-cooled units. These units require little or no maintenance.

**Figure 5.10: High-Voltage Line Reactor (500kV)**



**Figure 5.11: Low-Voltage Tertiary Reactor (13.8kV)**

Now let's examine the next piece of substation equipment, the synchronous condenser.

## Synchronous Condensers

### Definition: Synchronous Condenser

A **synchronous condenser** changes the power factor of the system by generating or absorbing Vars.

A synchronous condenser is basically a synchronous motor with no mechanical load or a synchronous generator with no prime mover. The condenser has a control circuit that provides voltage control by controlling the field excitation.

- If the system voltage decreases below a specified value, the control circuit increases the field excitation. This causes the synchronous condenser to supply Vars to the system, acting like a capacitor or overexcited generator.

- If the system voltage increases above a specified value, the control circuit decreases the field excitation. This causes the synchronous condenser to absorb Vars from the system, acting like a reactor or underexcited generator.

**Figure 5.12: Synchronous Condenser**



Now let's examine another piece of substation equipment, the lightning arrester.

## Lightning Arresters

Lightning arresters protect transformers and other power system equipment from voltage surges by shunting over-voltage to ground. Lightning arresters prevent flashovers and serious damage to equipment.

### Definition: Surge Arrester

Lightning arresters, also called **surge arresters**, conduct high-voltage current to ground without producing an excessive voltage. The arrester begins to conduct electricity at a specified voltage level well above the operating voltage. Then, the arrester becomes an open circuit when the over-voltage subsides and the current flowing through the arrester drops to a low value.

A lightning arrester includes the following elements:

- air gap
- resistive elements
- ground connection

**Figure 5.13: Diagram of a Lightning Arrester**

Figure 5.13 illustrates the following components of a lightning arrester:

- The air gap allows a high-voltage surge to jump across the gap to ground.
- Resistive elements allow high-voltage current to flow, but prevent current flow at line voltage.

**Figure 5.14: High-Voltage Lightning Arrester**

**Figure 5.15: High-Voltage Lightning Arrester on High-Voltage Bus**

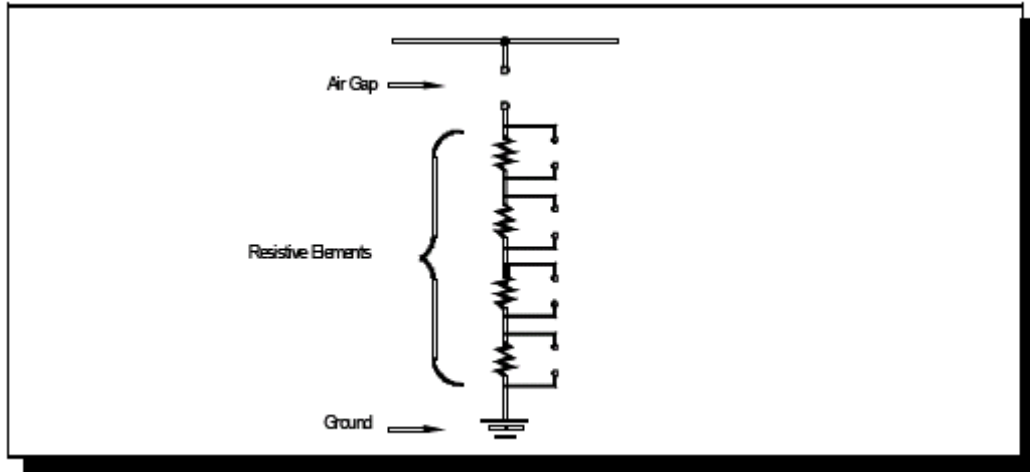
The last piece of substation equipment we discuss is the wave trap.

## Wave Traps

### Definition: Wave Trap

A **wave trap**, also called a **line trap**, is a device that presents:

- a very high impedance to high-frequency signals
- a negligible impedance to power system frequencies

Wave traps perform the following two functions:

- Prevents the communication system's energy from flowing into the substation bus. Without wave traps, the carriers on one line may interfere with power line carriers on other lines connected to the bus. This would compromise the

integrity of the protection system. We discuss protection systems in detail in **Module 8: System Protection**.

- Prevents an external ground fault behind the protection relays from short circuiting the carrier signal on the unfaulted line. In **Module 8: System Protection**, we examine how the protection system sends a blocking signal to prevent tripping during such faults. If the carrier short circuits, false tripping might occur.

**Figure 5.16: Wave Trap**



Now, let's examine the equipment in the substation control house.

## Section 5-3: Substation Control House

You may recall from reading **Section 5-1: Purpose of Substations**, that a substation includes a building that houses protection, control, metering, communications, and other equipment. This building is the substation control house.

The relays and meters in the control house receive information from power system equipment in the substation via cabling in an underground conduit. The information received includes:

- CT currents
- PT voltages
- circuit breaker statuses

Protection relays, supervisory control, programmable logic controllers, and/or manual control switches send control signals to power equipment in the substation.

### Control Panels

Utilities mount control house equipment on vertical panels. The front covers of protection relays and meters are visible through the panel. This provides a way for substation operators to obtain relay targets and read meters easily. Access to the wiring for each device is behind the panel.

The transformer control panel typically includes the following elements:

- Protection relays.
- Meters that display the high- and low-side current and other transformer quantities.
- Control switches that operate load-tap changers.
- Alarm annunciators that provide warnings of abnormal conditions, such as a transformer overload, high temperature, or high gas pressure.  
(Communications systems send these alarm indications to control centers.)

**Figure 5.16a: Upper Half of Transformer Relay Panel**



**Figure 5.16b: Bottom half of Transformer Relay Panel**



A transmission line control panel typically includes the following elements:

- control switches that manually operate the circuit breakers associated with the line
- status lamps that indicate the circuit breaker's status
- status lamps that indicate the circuit breaker's trip coil status
- status lamps that indicate whether the line is energized
- meters that indicate line voltage, current, and power flow
- communication transmitters and receivers for the protection systems associated with the line
- alarm annunciators that indicate abnormal conditions, such as low voltage or low circuit breaker pressure

**Figure 5.17: Transmission Line Relay Panel**



## Other Equipment

In addition to the equipment found on the control panels, control houses contain the following equipment:

- station batteries and motor-generator battery chargers
- EMS/SCADA remote terminal units
- Human-Machine Interface/Programmable Logic Controller
- fault and sequence-of-events recorders

We examine each of these separately in the next few pages, beginning with the station battery.

## Station Battery

The station battery provides DC power to the station control circuitry, which operates other equipment such as a circuit breaker's trip coils. The number of cells in the station battery determines what the appropriate battery voltage will be. For example, a 60-cell battery system will have a nominal voltage of 125 V DC. The batteries must provide sufficient voltage for operating circuit breakers and other vital substation equipment for a limited time period. The substation's AC maintains the charge on the batteries through the battery charger.

At critical high-voltage substations, utilities may install two separate batteries: a primary and a backup. A separate source charges each battery.

Utilities periodically check substation batteries for low voltage or dead cells. They correct any problems immediately since circuit breakers need DC power to trip.

**Figure 5.18: Substation Battery Bank**



## Energy Management System/Supervisory Control and Data Acquisition (EMS/SCADA) System Remote Terminal Units

Remote terminal units (RTUs) provide an interface between the substation equipment and the EMS/SCADA system at the control center. RTUs receive signals of important substation quantities (voltages, currents, equipment statuses, and alarms) and transmit them to a master station at the control center.

Conversely, system operators send control signals to substation equipment via the RTUs. We discuss EMS software functions in more detail in **Module 9: Principles of Power System Operation**.

### ***Programmable Logic Controller/Human-Machine Interface***

With the advent of affordable microprocessor-based relays and Programmable Logic Controllers, new equipment is beginning to populate substations.

#### **Definition: Programmable Logic Controller**

***Programmable Logic Controllers (PLC)*** perform all bank and line reclosing operations in place of a conventional electro-mechanical recloser. In addition to standard reclosing operations, the PLC can be programmed to perform conditional reclosing such as only reclosing a line circuit breaker upon detection of an energized line and then only after a predetermined period of time.

#### **Definition: Human-Machine Interface**

***Human-Machine Interfaces (HMI)*** contain the database of information collected from the PLC as well as any electronic protection relays connected to the HMI and acts as the intermediary between the PLC and RTU. Most of the remote and manual switching operations are performed through the HMI.

#### **Definition: Fault Recorder**

### **Fault and Sequence-of-Event Recorders**

Critical substations typically include subsystems that gather and store information needed to analyze abnormal events. Two of these subsystems are fault recorders and sequence-of-events recorders. ***Fault recorders*** log, on paper or in computer memory, critical current and voltage waveforms at the time of any fault. System engineers analyze the results.

**Definition: Sequence-of- Events Recorder**

**Sequence-of-Events (SOE) recorders** track the order in which events occur, such as the events in a relay operation or a circuit breaker opening. If we observe these events, they would appear to happen at the same instant. However, SOE recorders identify the correct order of events down to one-millisecond resolution. This information is often useful in determining whether protection systems operated as expected.

Now, let's examine some of the substation bus configurations.

<b>Section 5-4: Substation Bus Configurations</b>
---

There are five basic methods for connecting buses, circuit breakers, and circuits. Utilities may vary their method to meet their individual requirements based upon the following factors: cost, application, and required degree of service continuity and reliability.

The five basic arrangements are:

- Single Bus
- Main and Transfer Bus
- Ring Bus
- Breaker-and-a-Half Arrangement
- Double Bus-Double Breaker Arrangement

We examine each of these arrangements in the next few pages.

## Single Bus

Figure 5.19: Single Bus

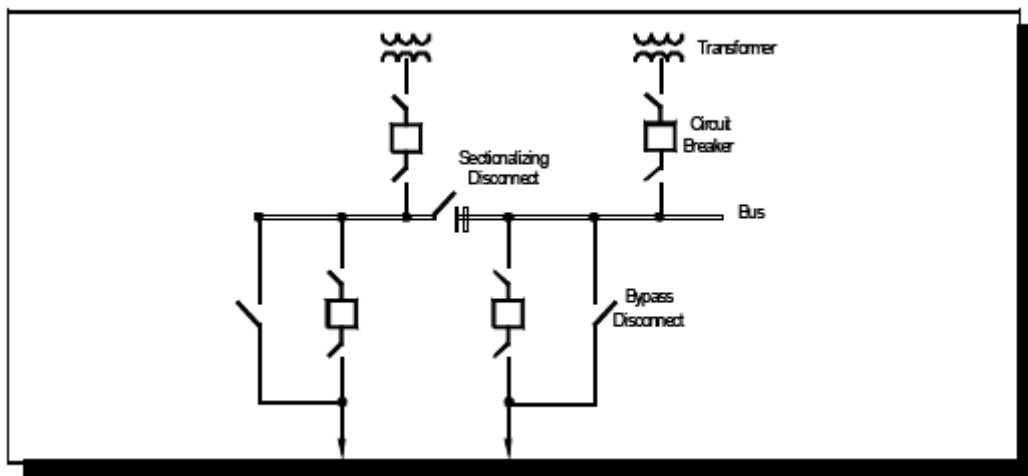

Figure 5.19 shows the following conditions in a single bus configuration:

- There is only one circuit breaker used per circuit.
- No transfer breakers and few disconnect switches are required.
- Maintenance work is difficult since most work requires the substation to be completely or partially out-of-service.
- Reliability is low since a bus fault or breaker failure can shut down the entire substation.

This is the simplest and most inexpensive arrangement of the five we are discussing, but the trade-offs are lower reliability and increased outage time for maintenance.

Let's examine another arrangement called the main and transfer bus.

## Main and Transfer Bus

Figure 5.20: Main and Transfer Bus

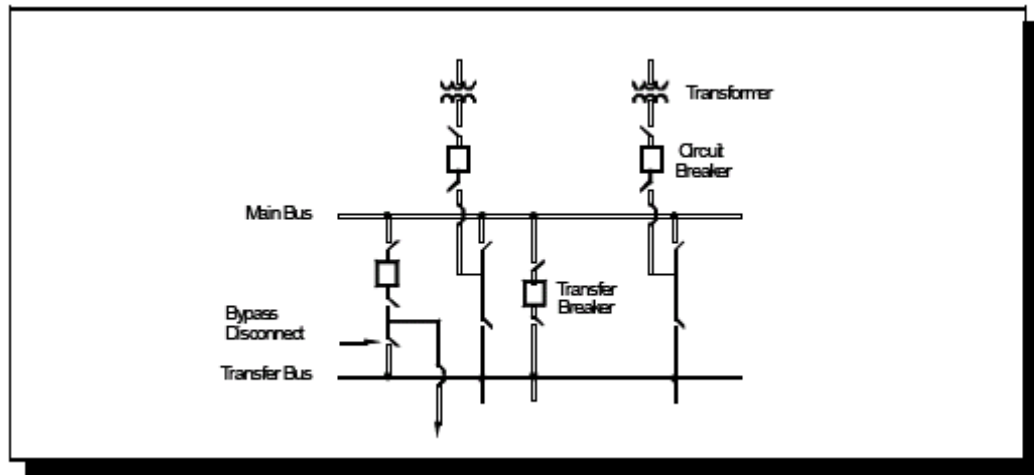

Utilities prefer this arrangement to the single bus arrangement since it allows them to perform maintenance without an interruption to service.

This arrangement provides a method of restoring service if there is a bus fault by transferring load from the main bus to the transfer bus. For substations that require the maximum practical reliability, utilities use the ring bus, breaker-and-a-half, or double bus-double breaker arrangements.

Let's examine each of these arrangements.

## Ring Bus

Figure 5.21: Ring Bus

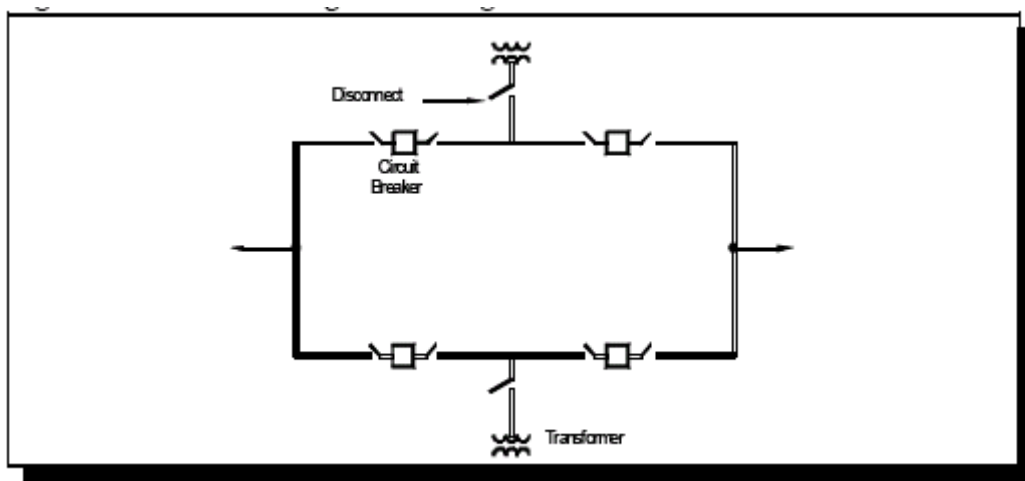

Figure 5.21 illustrates that the ring bus arrangement provides a double feed to all circuits. Power can flow around the bus between circuits in either direction.

This configuration uses the same number of breakers, fewer switches, and more steel than the single bus arrangement and offers several advantages, including:

- Isolation of the faulted section and interruption of only one circuit if a bus fault occurs. This is possible because the bus is separated into several parts. By opening two circuit breakers, we isolate part of the bus.
- The ability to take individual circuit breakers out of service for maintenance without interrupting any other circuits.

There is a disadvantage to this arrangement. When a breaker is out of service, the load current through the remaining breakers increases. Therefore, if an automatic operation of an in-service breaker occurs during maintenance of another breaker, a circuit may trip unnecessarily. If the number of circuits supplied by the bus greatly exceeds the number of circuits feeding the bus, another circuit may trip unnecessarily, if one breaker is already out for maintenance. This may cause interruption to more than one circuit. Therefore, utilities may choose not to use the ring bus if the ratio of outgoing to incoming circuits exceeds two or three.

Another configuration is a breaker-and-a-half scheme.

## Breaker-and-a-Half Arrangement

Figure 5.22: Breaker-and-a-Half Arrangement

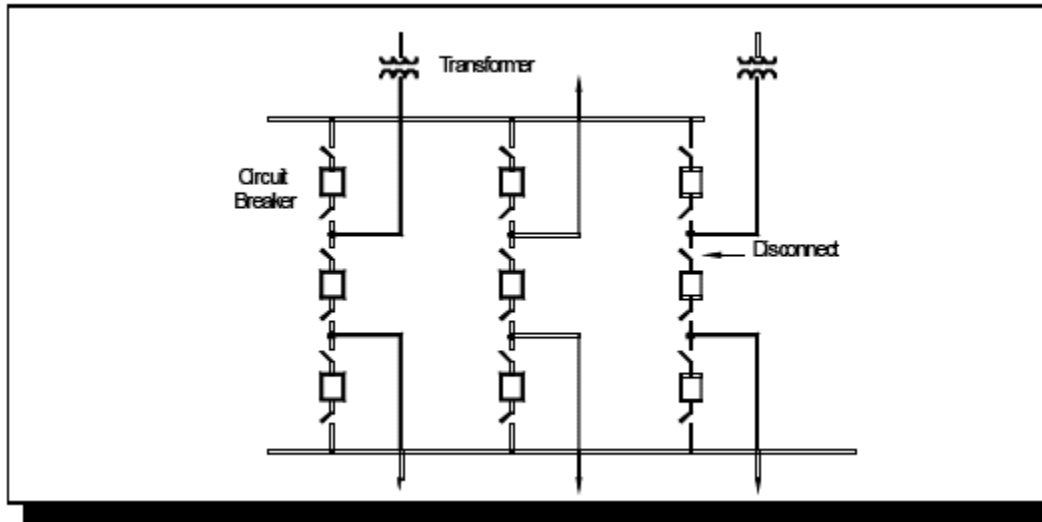

Figure 5.22 shows that each circuit has breaker protection, even when one breaker is out of service. A bus or breaker fault may have little effect on the reliability of the station, since we can isolate the fault.

This scheme is called breaker-and-a-half because there are three breakers for every two lines. That is an average of one and a half breakers per line.

This configuration has the same general advantages as the ring bus. To choose between the two configurations, utilities use the following guidelines:

- If the substation supplies only a few circuits, utilities use the ring bus. This is because the ring bus configuration requires fewer circuit breakers than the breaker-and-a-half scheme.
  - For example — to supply two lines in and out of the substation:
    - A ring bus configuration requires four breakers.
    - A breaker-and-a-half configuration requires six breakers.
- At stations with more lines, utilities use the breaker-and-a-half arrangement. While this scheme always requires more circuit breakers than the ring bus arrangement, fewer lines are interrupted if a fault occurs during breaker maintenance.

The last bus arrangement we discuss is the double bus-double breaker.

## Double Bus-Double Breaker Arrangement

Figure 5.23: Double Bus - Double Breaker Arrangement

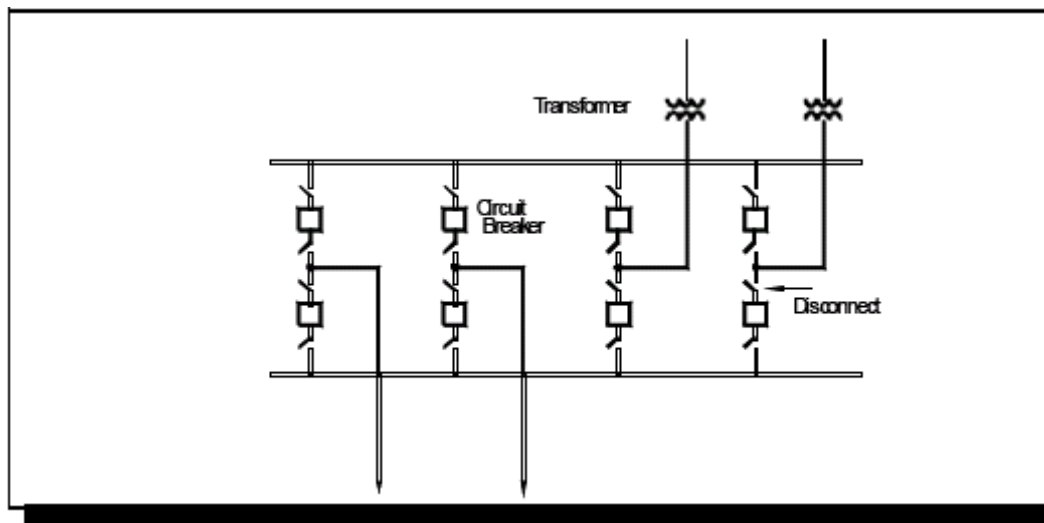

Figure 5.23 illustrates the following features of a double bus-double breaker arrangement:

It provides full protection for each circuit if any breaker is out of service.

- No breaker operation affects more than one circuit.
- The arrangement uses two buses, so one bus is available for maintenance without interrupting service.

This arrangement is very expensive to install. Utilities use this arrangement for substations that require the highest service reliability, continuity, and ease of switching.

**Conclusion:** This concludes the module on substation equipment. The purpose of this module is to discuss the purpose of the substation, the various pieces of equipment found in a substation, and some of the typical substation configurations. You should use this knowledge to review the equipment found in your utility's substations.

**Module 5 Substation Overview  
Question Set**

This page intentionally left blank.

**Module 5**  
**Substation Overview**  
**Question Set**

**5.1** Identify the purpose of a substation.

**5.2** Identify two functions performed by switchgear equipment.

**5.3** Identify three types of switchgear equipment.

**5.4** Provide the following information about circuit breakers:

**(a)** Define restriking.

**(b)** Describe the two most common methods of extinguishing an arc.

**(c)** List three types of circuit breakers.

**5.5** Match the term in Column 1 with its definition in Column 2.

Column 1	Column 2
___ Maximum continuous current capability	<b>A.</b> The maximum fault current a piece of equipment is capable of interrupting.
___ Maximum interrupting current	<b>B.</b> Time period from the instant current begins to flow through the trip coil until the circuit breaker interrupts the fault.
___ Interrupting time	<b>C.</b> The highest load current that a piece of equipment is designed to carry for extended time periods.
___ Closing time	<b>D.</b> Time it takes to close a circuit breaker from the time the close coil is energized until current begins to flow through the breaker.

**5.6** True or False: A load break switch can be used to interrupt fault current.

**5.7** True or False: A disconnect switch is always used to interrupt normal load currents.

**5.8** List three uses of capacitors on the power system.

**5.9** True or False: Reactors and capacitors both absorb Vars.

**5.10** Describe the function of a synchronous condenser.

**5.11** Describe the function of a lightning arrester.

**5.12** List two functions of a wave trap.

**5.13** Describe the function of a fault recorder.

**5.14** What is the purpose of a sequence-of-events recorder?

5.15 Match the bus configuration listed in Column 1 with the illustration in Column 2:

- A. Single bus
- B. Main and transfer bus
- C. Ring bus
- D. Breaker-and-a-half
- E. Double bus-double breaker

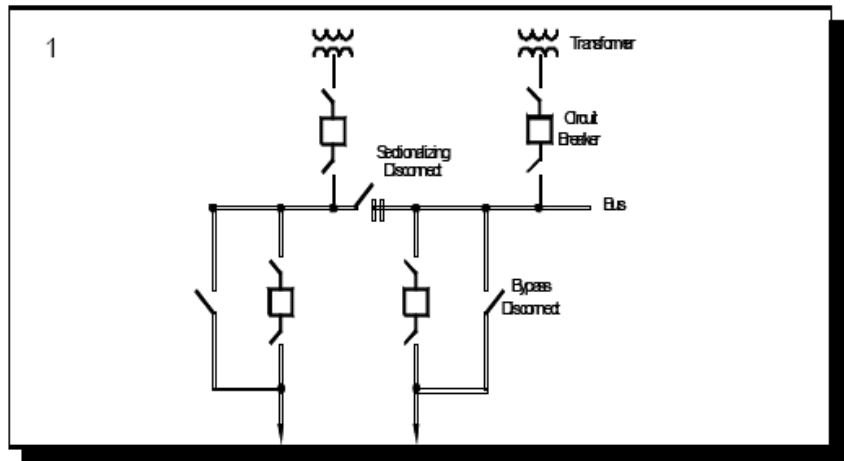

- A. \_\_\_\_\_
- B. \_\_\_\_\_
- C. \_\_\_\_\_
- D. \_\_\_\_\_
- E. \_\_\_\_\_

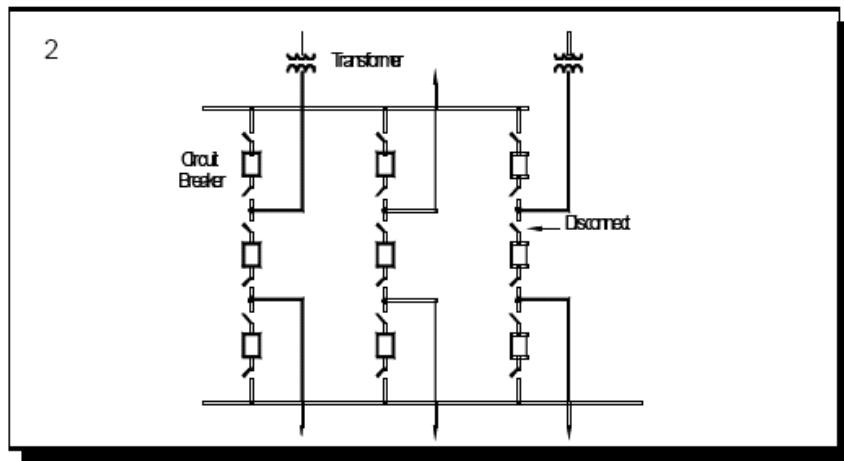

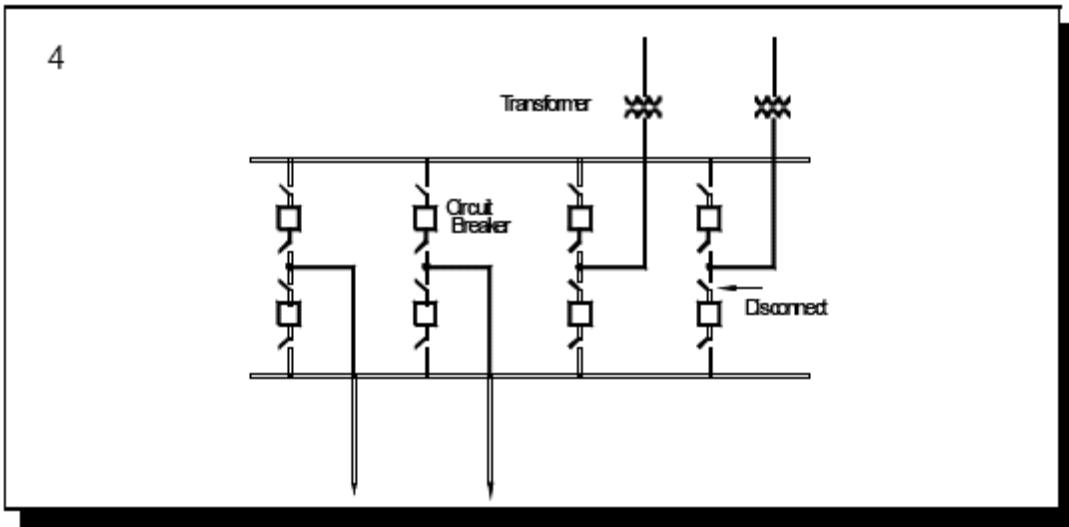
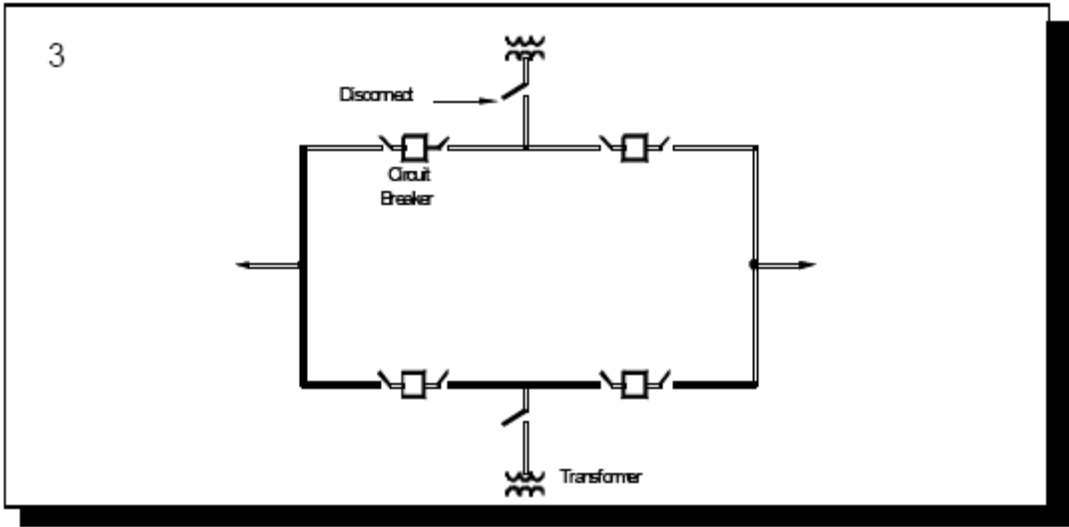

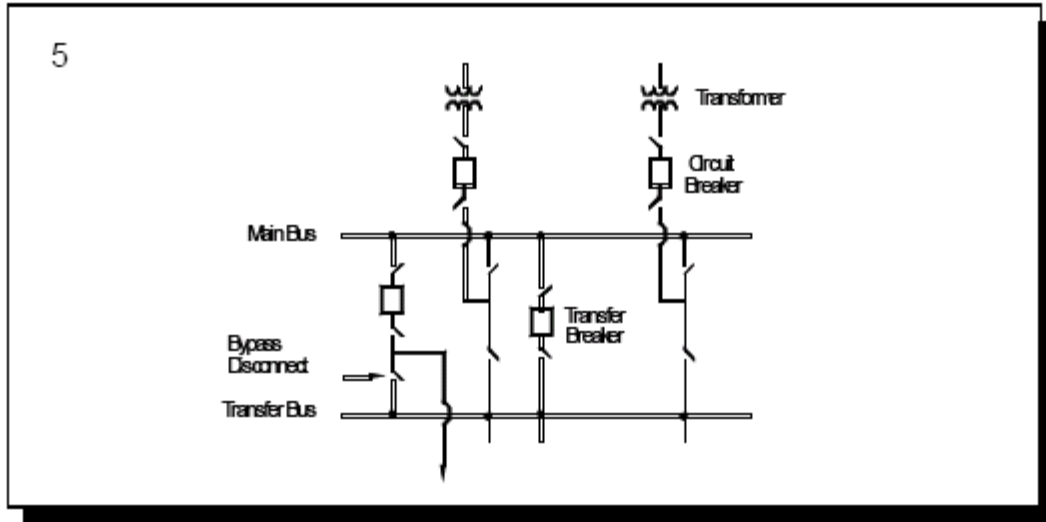

**5.16** What is the simplest and most inexpensive bus arrangement?

This page intentionally left blank.



## **Module 6: Transformers**

## Module 6: Transformers

### Table of Contents

<b>Transformers .....</b>	<b>6-3</b>
<b>Section 6.1: Principle of Operation.....</b>	<b>6-3</b>
Transformer Efficiency.....	6-10
Voltage Control.....	6-11
Three-Phase Transformer .....	6-12
<b>Section 6.2: Types of Transformers .....</b>	<b>6-14</b>
Power Transformers .....	6-14
Autotransformers .....	6-15
Phase Shifting Transformers .....	6-16
Instrument Transformers .....	6-17
Distribution Transformers .....	6-18
<b>Section 6.3: Operating Consideration and Limitations.....</b>	<b>6-18</b>
Transformer Cooling Systems .....	6-18
Transformer Ratings.....	6-18
<b>Module 6: Transformers Question Set .....</b>	<b>6-21</b>

### Table of Figures

Figure 6.1: Two-Winding Transformer.....	6-3
Figure 6.2: Transformer Parameters .....	6-6
Figure 6.3: Three-Phase Transformer .....	6-12
Figure 6.4: Transformer Connections.....	6-13
Figure 6.5 Autotransformer .....	6-15
Figure 6.6: Phase Shifting Transformer.....	6-16
Figure 6.7: Phase Voltage Advancement.....	6-17

# Transformers

## Module Overview

The **Transformers** module presents the following topics:

- Principle of Operation
- Types of Transformers
- Operating Considerations and Limitations

## Section 6.1: Principle of Operation

The purpose of a transformer is to change an electric system quantity (e.g., voltage or current) from one level to another.

### Definition: Windings

A transformer is made up of two or more conductors wound around a single magnetic core, usually iron. The wound conductors, usually copper, are called **windings**.

**Figure 6.1: Two-Winding Transformer**

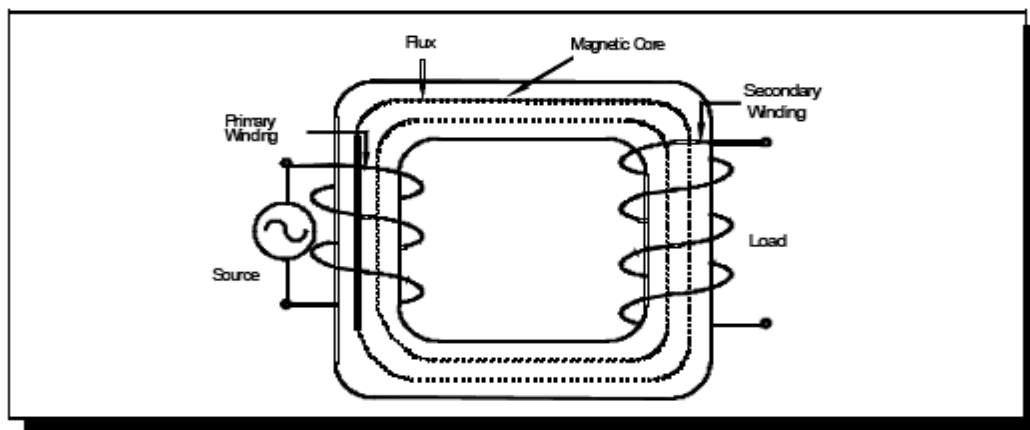

Figure 6.1 illustrates the following:

**Definition: Primary Winding**

The **primary winding** is electrically connected to the power source.

**Definition: Secondary Winding**

- The **secondary winding** is electrically connected to the energy output or load side.
- There is no electrical connection between the primary and secondary windings.

**Definition: Tertiary Winding**

Sometimes a third winding, the **tertiary winding**, is present. A tertiary winding provides power to an auxiliary circuit or a reactor.

The core and the windings are mounted in a steel tank filled with mineral oil or some other liquid suitable for insulating and cooling. Insulated bushings, usually mounted at the top of the tank, connect the windings to other power system equipment.

How does a transformer work?

You may recall from reading **Module 2: Fundamentals of Electricity**, that transformers operate using the principle of electromagnetic induction.

We summarize the principle of electromagnetic induction below:

- Passing an alternating current through a coil causes an alternating magnetic flux in the magnetic core.
- The magnetic flux circulates in the magnetic core, passing through another coil (the secondary winding), inducing an alternating voltage in this coil.
- The amount of induced voltage depends upon four factors:
  - 1) core composition and shape
  - 2) number of turns in primary coil or winding
  - 3) number of turns in the secondary coil or winding
  - 4) primary voltage

In a transformer there are two or more coils linked together by a common core - conducting the magnetic flux. Flux from one coil (the primary winding) passes through the other coil (the secondary winding), inducing a voltage in the secondary winding. Mutual induction links the two windings.

The primary winding converts the electrical energy from an AC source into magnetic energy (flux). This establishes an alternating magnetic flux in the transformer's core.

The secondary winding converts the magnetic energy back into electrical energy to be used by the load.

**Definition: Turns Ratio**

At the beginning of this section, we state that the transformer's purpose is to change an electric system quantity from one level to another. The amount a quantity changes is determined by the **turns ratio**, which is the ratio of the number of turns in the two windings.

The magnetic flux links the turns of the primary and secondary windings. This induces a voltage in each winding. Since the same flux cuts both windings, the same voltage is induced in each turn of both windings. Therefore, the total voltage in each winding is proportional to the number of turns in that winding:

$$\frac{V_1}{V_2} = \frac{N_1}{N_2}$$

Where:

$V_1$  and  $V_2$  are the voltages in the primary and secondary windings, respectively.

$N_1$  and  $N_2$  are the number of turns in the primary and secondary windings, respectively.

We know from **Module 2: Fundamentals of Electricity**, that inductance is the electrical circuit property that opposes the change of current. The following statements describe the relationship between flux and inductance:

- Increasing the current flow increases the magnitude of the flux.
- Increasing the turns in the conductor increases the concentration of flux.
- Increasing the flux concentration increases induction.
- Inductance causes the current to lag the voltage. The current may lag the voltage in a transformer by a maximum of  $90^\circ$ .

Figure 6.2: Transformer Parameters

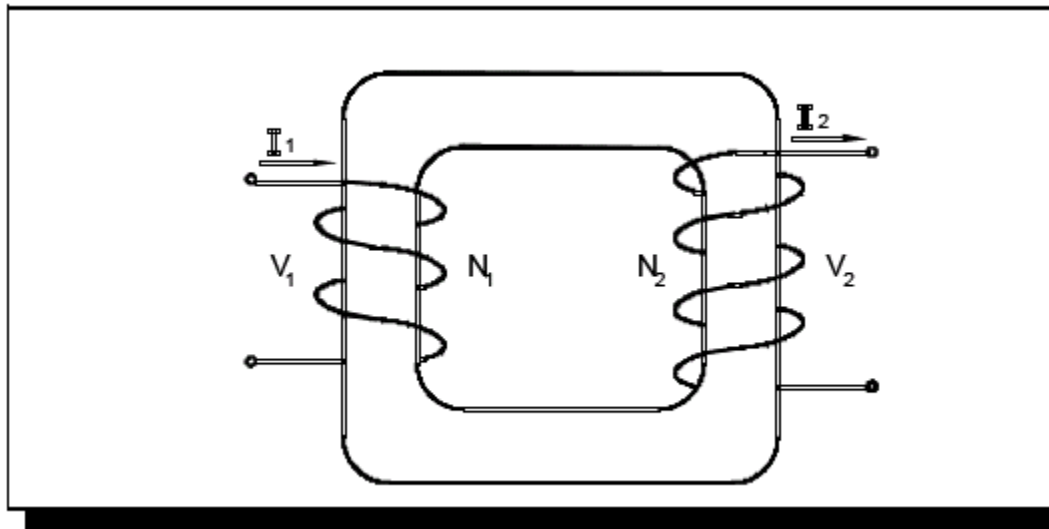

Referring to Figure 6.2, the following relationships exist:

$$\frac{V_1}{V_2} = \frac{N_1}{N_2} \quad \frac{I_1}{I_2} = \frac{N_2}{N_1} \quad P_1 = V_1 I_1 \cos\theta \quad P_2 = V_2 I_2 \cos\theta$$

where:

$V_1$  = Voltage on primary side .....  $I_1$  = Current flow on primary side

$V_2$  = Voltage on secondary side .....  $I_2$  = Current flow on secondary side

$N_1$  = Turns on primary side .....  $P_1$  = Power into primary side

$N_2$  = Turns on secondary side .....  $P_2$  = Power out of secondary side

$\theta$  = Electrical angle between voltage and current

There is one additional relationship we must consider – the relationship between  $P_1$  and  $P_2$ . In an ideal transformer, the power into the transformer is equal to the power out of the transformer. In other words, there are no losses. Therefore, the following relationship exists:

$$P_1 = P_2$$

Using the relationships, we can determine the changes across a transformer.

Let's apply these relationships to an example:

A transformer has 300 turns on its primary winding and 600 turns on its secondary winding. The input voltage is 120 volts. What is the output voltage?

The given quantities are:

- $V_1 = 120$  volts
- $N_1 = 300$  turns
- $N_2 = 600$  turns

### ***Determining Output Voltage***

To determine the output voltage or the voltage on the secondary side ( $V_2$ ) we use this equation:

$$\frac{V_1}{V_2} = \frac{N_1}{N_2}$$

Substituting into this equation the values we are given, we have the following relationship:

$$\frac{120}{V_2} = \frac{300}{600}$$

Now, we cross-multiply to determine the one unknown value,  $V_2$ :

$$300 \times V_2 = 120 \times 600$$

Solving for  $V_2$ , we have:

$$300 V_2 = 72,000$$

$$V_2 = \frac{72,000}{300}$$

$$V_2 = \mathbf{240\ V}$$

### ***Determining Current Output***

If we are given  $I_1$ , we can determine the secondary current,  $I_2$ , by using the following equation:

$$\frac{I_1}{I_2} = \frac{N_2}{N_1}$$

If  $I_1 = 800$  amps, by substituting the given values into the equation we have:

$$\frac{800}{I_2} = \frac{600}{300}$$

To determine  $I_2$ , we cross-multiply and solve for  $I_2$ :

$$600 I_2 = 800 \times 300$$

$$600 I_2 = 240,000$$

$$I_2 = \frac{240,000}{600}$$

$$I_2 = \mathbf{400 \text{ A}}$$

### ***Determining Power***

Remember, the power remains the same across the transformer. So, let's check to make sure the power into the transformer is the same as the power coming out of the transformer. (For purposes of this example, assume a resistive load; therefore,  $\cos \theta = 1$ .)

$$P_1 = V_1 \times I_1 \times \cos \theta$$

$$P_1 = 120 \text{ V} \times 800 \text{ A} \times 1$$

$$P_1 = 96,000 \text{ Watts}$$

$$P_1 = \mathbf{96 \text{ kW}}$$

$P_2$  should be the same. Let's see.

$$P_2 = V_2 \times I_2 \times \cos \theta$$

$$P_2 = 240 \text{ V} \times 400 \text{ A} \times 1$$

$$P_2 = 96,000 \text{ Watts}$$

$$P_2 = \mathbf{96 \text{ kW}}$$

These calculations show that the power on the primary side of the transformer equals the power on the secondary side of the transformer.

### **Definitions: Step-Up Transformer and Step-Down Transformer**

In the example above, the transformer changed the primary-side voltage from 120 V to a secondary voltage of 240 V to decrease the current on the secondary side. This is an example of a **step-up transformer**; the voltage was stepped up from 120 V to 240 V. Conversely, a transformer in which the energy transfer is from a high-voltage circuit to a low-voltage circuit is a **step-down transformer**.

We can see from the example that whatever happens to the voltage through the transformer, the opposite happens to the current.

- If the voltage is stepped down, current is stepped up by the same ratio.
- Likewise, when voltage is stepped up, current is stepped down by the same ratio.

Some important concepts to remember about transformers include:

Transformers do not produce electricity. They only transform it from one level to another; i.e., step the voltage or current up or down.

Although transformers take certain levels of voltage and current and change them to other levels, the total amount of power does not change from one side of the transformer to the other, if losses are ignored.

- The power on the primary side equals the power on the secondary side, if the transformer is without losses. In reality, transformers experience some losses. We discuss losses later in this module.
- For a given value of power, the higher the voltage, the lower the current for use by the transmission system. Using lower current decreases losses. This is why transmission systems use high voltage. In **Module 3: Power System Overview**, we discuss the step-up transformers at generating stations. These transformers raise the generator output voltage.

While the transformer is operating, some electrical energy is converted into heat. But we know the purpose of the transformer is not to provide heat. The purpose is to transfer electrical energy from the primary to the secondary winding. Therefore, any heat the transformer produces is an energy loss and represents inefficiency.

What determines a transformer's efficiency?

Let's find out.

## Transformer Efficiency

The efficiency of a transformer is the ratio of the output power to the input power.

$$\text{Efficiency} = \frac{\text{Output Power}}{\text{Input Power}} \times 100$$

But we stated earlier that the power into a transformer is equal to the power out of the transformer, therefore the efficiency equals 100%. This is the ideal case. In reality, the transformer consumes some of the power. Most transformers have an efficiency of between 97% and 99%.

### Definition: Power Loss

The power consumed is called *power loss*. It is caused by the following:

- hysteresis losses
- eddy current losses
- copper ( $I^2R$ ) losses

Hysteresis and eddy current losses occur in the transformer's core.

Copper losses occur in the windings.

All three loss types involve the conversion of electrical energy into heat energy.

### Definition: Residual Magnetism

Hysteresis loss is due to ***residual magnetism***, which is the magnetism that remains in a material after the magnetizing force is removed. The transformer core reverses magnetic polarity each time the primary current reverses direction. Every time the magnetic polarity reverses, the residual magnetism of the previous polarity has to be overcome. This produces heat. Hysteresis loss is the energy required to reduce the residual magnetism to zero and occurs every half cycle just before the core is re-magnetized in the opposite direction.

**Definition: Eddy Current**

**Eddy current** is the current that flows in the transformer's core and results from the voltage that is induced in the core by the primary winding. We know that the primary coil creates a flux that induces a voltage in the secondary coil. The flux also cuts the core, and we know that when a varying flux passes through a conductor it induces voltage. The core is itself a conductor. So a voltage is induced in the core as well as in the secondary winding. In the core, the energy is converted to heat. Eddy current can be reduced by laminating the transformer's core with a higher resistance material.

**Definition: Copper Loss ( $I^2R$  losses)**

**Copper loss** is the power dissipated in the transformer windings. Using larger conductors for the transformer windings reduces the copper loss, but the conductor size is limited by the openings in the core into which the winding must fit. However, larger conductors may be required to sustain higher currents.

## Voltage Control

**Voltage Control Definition: Tap**

Most high-voltage transformers contain taps on the windings for changing the transformer's turns ratio. A **tap** is a connection at some point on a primary or secondary winding which permits changing the turns ratio. Changing the turns ratio alters the secondary voltage and current.

If the need for voltage adjustments is infrequent (e.g., adjustments are made for load growth or seasonal variations), utilities use no load de-energized tap changers. As the name implies, the transformer is de-energized prior to changing taps.

**Definition: LTC Transformer**

Where frequent voltage adjustments are necessary, or in cases of a transformer that cannot be de-energized without jeopardizing customer service, utilities use load-tap-changing (LTC) transformers. LTC transformers, sometimes called **tap-changing under load (TCUL)** transformers, change transformer taps automatically, remote manually via Supervisory Control and Data Acquisition (SCADA), or manually by local control, while the transformer is energized.

- The tap changer is operated by a motor that responds to relay settings to hold the voltage at a pre-determined level.
- Special circuits allow the tap to be changed without interrupting current.

The load-tap changing equipment is usually housed in a separate compartment on the side of the transformer. Load-tap changing equipment is used on power transformers, autotransformers, and distribution transformers.

## Three-Phase Transformer

Up to this point we have been discussing single-phase transformers.

Three-phase transformers operate using the same principles: passing an alternating current through a primary winding causes an alternating magnetic flux in the core, which induces an alternating voltage in the secondary winding.

In three-phase transformers there are three primary windings and three secondary windings.

- Some three-phase transformers include windings for all three phases in one tank.
- Other three-phase transformers have three single-phase transformers connected together.

**Figure 6.3: Three-Phase Transformer**

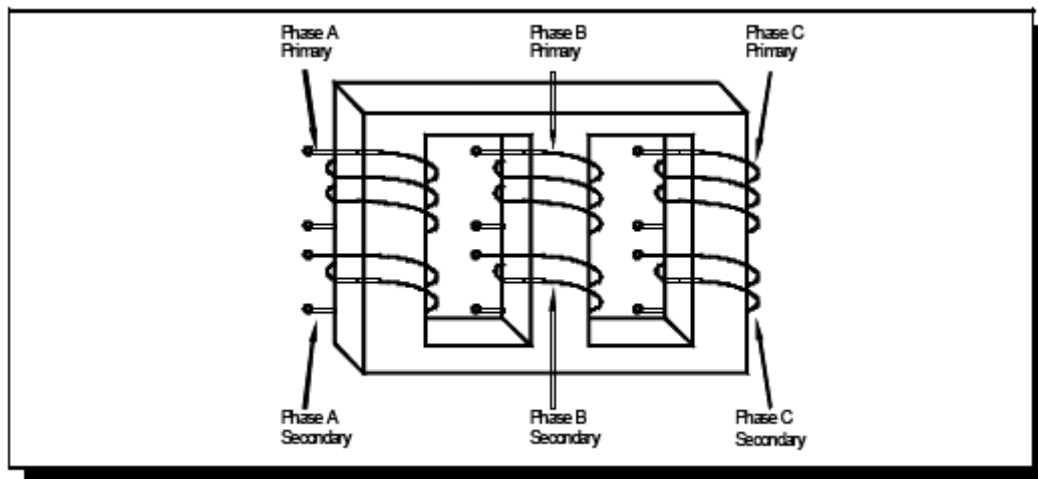

At higher voltages, utilities use three single-phase transformers connected together. In that case:

- The primary windings for each phase are connected.
- The secondary windings for each phase are connected.
- However, the primary windings are not connected to the secondary windings.

### Definition: Transformer Bank

The connection of two or more single-phase transformers as a unit is called a **transformer bank**. The most common methods for connecting the windings are:

- Wye or Y (sometimes called star) connection
- Delta connection

We discuss the Wye and Delta connections in **Module 2: Fundamentals of Electricity**. Some methods of connecting the windings result in a voltage phase difference between the primary and the secondary windings. This is called a phase shift. The primary and secondary windings need not have the same configuration.

**Figure 6.4: Transformer Connections**

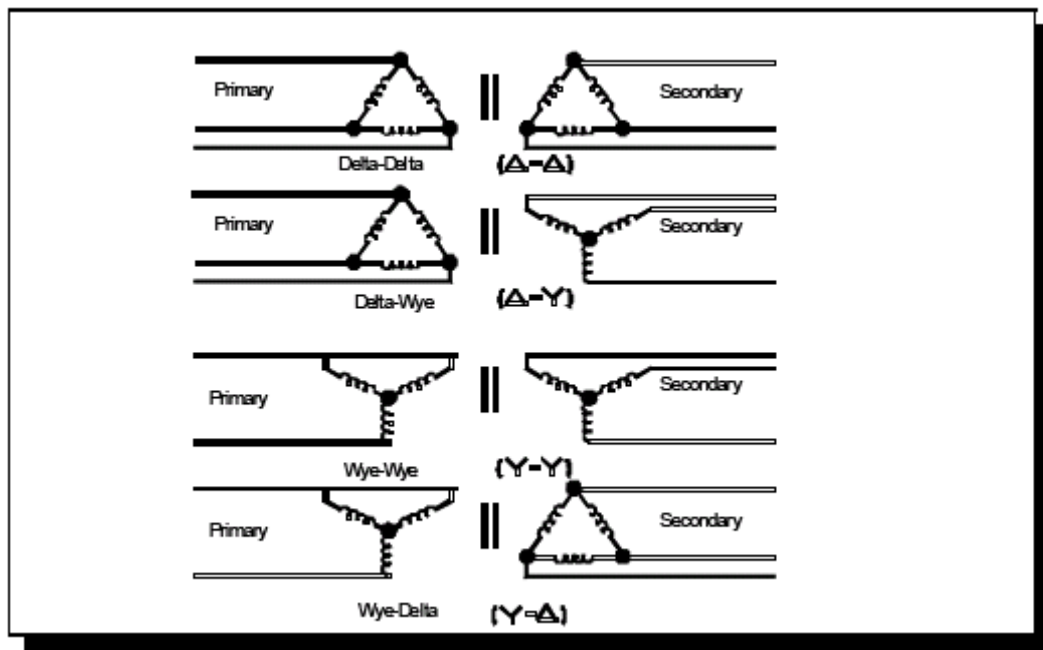

The four possible transformer winding connections are:

1. Delta-Delta Connection - The primary windings and secondary windings are Delta-connected. This connection does not introduce a phase shift between the primary and secondary voltages.
2. Delta-Wye Connection - The primary windings are Delta connected and the secondary windings are Wye connected. This connection introduces a  $30^\circ$  phase shift. For example, Phase A voltage on the primary side is  $30^\circ$  out of phase with Phase A's voltage on the secondary side.

3. Wye-Wye Connection - The primary and secondary windings are Wye connected. This connection does not introduce a phase shift between the primary and secondary voltages.
4. Wye-Delta Connection - The primary windings are Wye connected and the secondary windings are Delta connected. This connection also introduces a 30° phase shift.

**Note:** *In some transformers, the neutral point in the Y connection is grounded.*

We must consider these phase shifts before tying together circuits fed through different types of transformers. For example, connecting a circuit fed by a Wye-Delta bank to a circuit fed by a Wye-Wye bank results in excessive current flow because of the 30° phase difference.

Now, let's discuss some types of transformers.

## Section 6.2: Types of Transformers

In this section, we discuss the following types of transformers:

- Power Transformers
- Autotransformers
- Phase Shifting Transformers
- Instrument Transformers
- Distribution Transformers

### Power Transformers

#### **Definition: Power Transformer**

**Power transformer** is a term given to a transformer used to transfer power for voltages higher than 69 kV. Most power transformers are three-phase. Power transformers can step-up or step-down the voltage. Other capabilities can be added to a step-up or step-down transformer, such as tap changing equipment.

## Autotransformers

### Definition: Autotransformer

An **autotransformer** is a single-winding transformer with a terminal that divides the winding into two sections. Autotransformers are useful because they are simply constructed and cost relatively little compared with multi-winding transformers.

Autotransformers are variously designed to raise or lower the voltage at  $\pm 5\%$ ,  $\pm 7.5\%$ , or  $\pm 10\%$  ranges.

Figure 6.5 Autotransformer

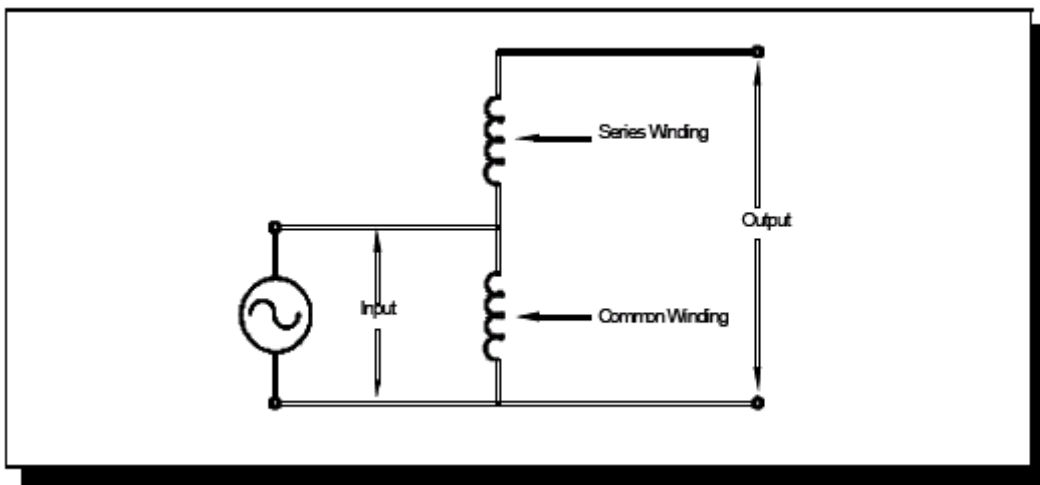

Figure 6.5 illustrates the following concepts about an autotransformer:

### Definition: Common Winding

Part of the winding is common to both the primary and secondary circuits. The common portion is called the **common winding**.

### Definition: Series Winding

The remaining portion of the winding is called the **series winding**.

- For the illustrated transformer, the secondary winding consists of the common winding and the series winding. This is a step-up autotransformer.
- In a step-down autotransformer the secondary winding consists of the common winding only.

Autotransformers typically have lower losses than a power transformer and are smaller in size and weight. As a result, autotransformers are usually more

economical than power transformers and are used to transfer energy between two circuits of nearly the same voltage.

Another type of transformer is the phase shifting transformer.

## Phase Shifting Transformers

### Definition: Phase Shifting Transformers

**Phase shifting transformers**, sometimes called phase angle regulators (PARS), control power flow over parallel lines by adjusting the voltage phase angle at one end of the line.

Phase shifting transformers increase or decrease the phase angle differences between buses. Inserting a phase shifting transformer on a transmission line changes the power flow over the line by changing the phase angle between locations thus redistributing the power flow.

The operation of phase shifting transformers is similar to the operation of power transformers. The interconnection of the windings within the transformer creates the phase shift.

Figure 6.6: Phase Shifting Transformer

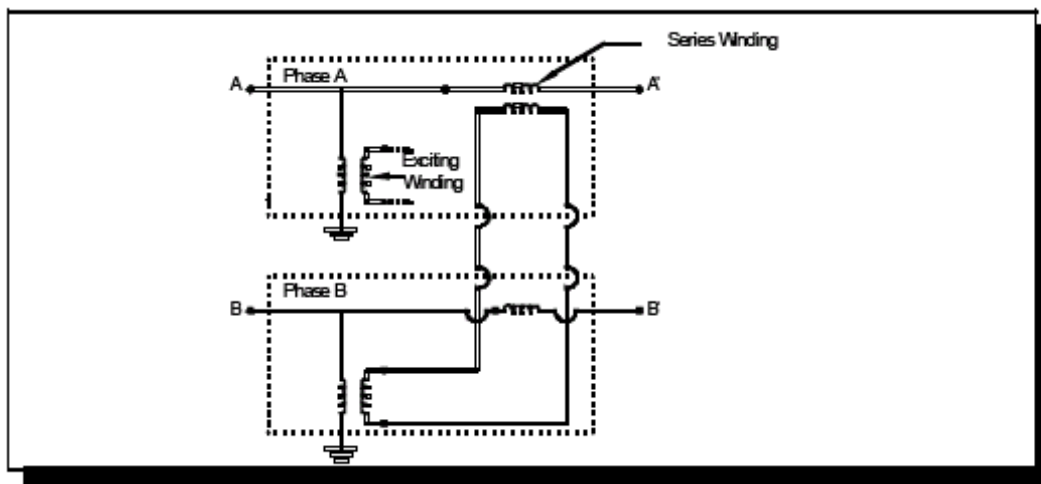

**Figure 6.7: Phase Voltage Advancement**

Figure 6.6 shows how the phase voltages can be added to adjust the phase angle. For simplicity, Figure 6.6 shows Phase A connections only.

- The Phase A series winding's secondary is connected to Phase B's exciting winding.
- Phase B's voltage lags Phase A's voltage by  $120^\circ$  (or  $60^\circ$  leading if the polarity is reversed).
- The Phase B exciting winding induces a voltage in the Phase A series secondary winding. This small out-of-phase voltage advances the supply voltage as shown in Figure 6.7.

Interconnecting the phases provides phase angle control. In essence, a voltage is derived from one phase and inserted into another phase.

The next kind of transformer we discuss is the instrument transformer.

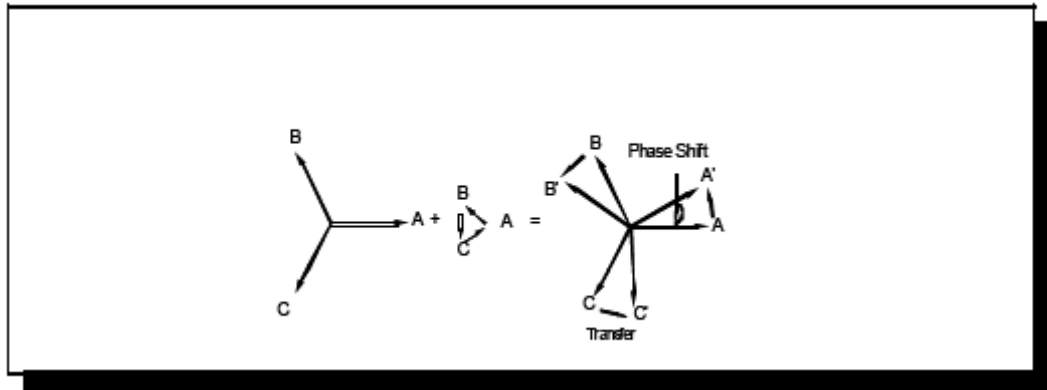
## Instrument Transformers

### Definition: Instrument Transformers

In high-voltage systems, direct measurement of voltage or current is not practical. We must scale down the values for use by meters and relays. **Instrument transformers** perform this function.

Instrument transformers include current transformers (CTs) and potential transformers (PTs) (sometimes called voltage transformers [VTs]). Both of these transformers reduce system current and voltage to lower values for use by the relays and control circuitry. We discuss CTs and PTs in more detail in **Module 8: System Protection**.

The last kind of transformer we examine is the distribution transformer.

## Distribution Transformers

### Definition: Distribution Transformers

A ***distribution transformer*** reduces voltage to a level that is usable by customers. Distribution transformers are mounted on poles, on concrete pads, or in underground vaults. Their operation is similar to a power transformer.

Now, let's examine some limitations and operating considerations for transformers.

### Section 6.3: Operating Consideration and Limitations

In this section we examine the following topics:

- Transformer Cooling Systems
- Transformer Ratings

### Transformer Cooling Systems

Excessive heating in the transformer causes the insulation to deteriorate; therefore, it is important to prevent overheating. The technology for this is based on the idea that oil cools the core and windings. Transformer manufacturers equip transformers with cooling systems that prevent the permissible temperature rise of the insulating oil from exceeding specifications. Cooling systems for large power transformers typically include:

- radiators in which outside air cools the transformer oil that circulates by convection through the radiators
- pumps to increase the circulation rate when additional cooling is needed
- fans that blow air on the radiators for added cooling

### Transformer Ratings

Heat generated within the transformer tank causes the transformer insulation to deteriorate gradually. While some heating is unavoidable, excessive heating can cause rapid deterioration and breakdown of the transformer insulating materials.

**Definition: Transformer Rating**

The ***transformer rating*** is the maximum power that the transformer can safely carry without exceeding a temperature limit and is expressed in MVA. Transformers typically have more than one rating depending on the portion of the transformer cooling system that is operating.

**Definition: FOA Rating**

The ***forced-oil and air (FOA) rating*** is the maximum rating that applies when oil pumps and cooling fans are operating.

**Definition: FA Rating**

The ***forced air (FA) rating*** applies when the fans are running but the oil pumps are not running (oil is flowing by natural circulation). This is approximately 80% of the maximum rating.

**Definition: OA Rating**

The ***oil to air (OA) rating*** applies when neither the fans nor the oil pumps are running. This is approximately 60% of maximum rating.

It is important to detect faults in the transformer windings before damage occurs. Major problems that cause extensive damage in transformers usually start out as small short-circuits between turns. These short circuits usually develop into an arc, which produces large volumes of gas by chemically decomposing the insulating oil.

Relays that detect rising internal gas pressure in the tank are able to detect such faults while they are still relatively minor. However, these relays cannot be too sensitive, or they operate needlessly for pressure surges caused by sudden changes in current flow, such as those caused by external faults.

It is important to be able to determine:

- whether a transformer relay operated incorrectly, in which case the operator should restore the transformer to service.
- whether there is a minor internal fault that should be repaired prior to re-energizing the transformer to prevent more extensive damage.

Following a transformer relay operation, substation personnel typically perform inspections to determine whether an internal short circuit is present.

They may:

- Perform a resistance check to determine whether normally energized parts have come in contact with normally non-energized parts.
- Draw gas and oil samples from the tank and have the samples analyzed to determine whether excessive decomposition due to arcing has occurred.
- Measure the turns ratio to determine whether a short circuit has occurred between turns.

If test results indicate that no internal fault exists, the transformer can be re-energized.

As a preventive measure, utilities periodically inspect transformers to identify possible problems. Most transformers include gauges for reading transformer loading, oil levels and temperatures, and gas pressures and temperatures to assist in performing these inspections.

**Conclusion:** This concludes the module on transformers. We have discussed the operating principles and some types of transformers. You should review the operating considerations for the transformers in use at your utility.

**Module 6: Transformers  
Question Set**

## Module 6 Transformers Question Set

- 6.1** State the purpose of a transformer.
- 6.2** Complete the following statements about transformer windings:
- (a)** The transformer winding that is electrically connected to the energy output or the load side is the **primary winding/secondary winding/tertiary winding** (circle one).
  - (b)** The transformer winding that is electrically connected to the power source is the **primary winding/secondary winding/tertiary winding** (circle one).
  - (c)** True/False: There is no electrical connection between the primary and secondary windings.
- 6.3** Transformers operate using the principle of:
- (a)** Electron theory
  - (b)** Electromagnetic induction
  - (c)** Primary/secondary transfer theory
  - (d)** Turn ratio theory

- 6.4** What is the amount of induced voltage in the secondary winding dependent on?
- 6.5** If the primary (input) voltage is 69 kV and the transformer has 300 turns on its primary winding and 100 turns on its secondary winding, what is the secondary voltage? Is this a step-up or a step-down transformer?
- 6.6** True/False: Transformers produce electricity.
- 6.7** List three causes of power loss in a transformer.

**6.8** Provide the following information on transformer winding connections:

- (a) List the two most common methods for connecting the windings.
  
- (b) True/False: A Delta-Delta connection results in a voltage phase shift between the primary and secondary voltages.
  
- (c) True/False: A Delta-Wye connection results in a voltage phase shift between the primary and secondary voltages.

**6.9** What is the major difference between a phase shifting transformer and a power transformer?

**6.10** Match the type of transformer in Column 1 with its definition in Column 2:

<b>Column 1</b>	<b>Column 2</b>
____ Power transformer	A. Transformer used to transfer power for voltages higher than 69 kV.
____ Autotransformer	B. Transformer that controls power flow over parallel lines by adjusting the voltage phase angle at one end of the line.
____ Phase shifting transformer	C. Transformer used to reduce the voltage to a level that is usable by a system.
____ Instrument transformer	D. Transformer that scales down voltage or current values for use by meters and relays.
____ Distribution transformer	E. Single-winding transformer with a terminal that divides the winding into two sections.



**Module 7:  
Power Transmission**

This page intentionally left blank.

## Module 7: Power Transmission

### Table of Contents

<b>Power Transmission.....</b>	<b>7-5</b>
<b>Section 7.1: Components and Interconnections.....</b>	<b>7-5</b>
Conductors.....	7-6
Towers.....	7-7
Insulators.....	7-8
Shield Wires.....	7-9
Rights-of-Way.....	7-10
Interconnection of Transmission Lines.....	7-10
<b>Section 7.2: Electrical Model.....</b>	<b>7-12</b>
Resistance.....	7-13
Reactance.....	7-13
Voltage and Power Flow.....	7-14
<b>Section 7.3: Operating Considerations.....</b>	<b>7-15</b>
Controlling Real Power Flow.....	7-15
Phase Shifting Transformers.....	7-17
Series Capacitors.....	7-17
Controlling Voltage and Reactive Power Flow.....	7-18
Shunt Reactors.....	7-18
Shunt Capacitors.....	7-19
Generators.....	7-19
Transposing Conductors.....	7-19
<b>Section 7.4: Circuit Restoration.....</b>	<b>7-20</b>
<b>Section 7.5: High Voltage Direct Current.....</b>	<b>7-21</b>
Principle of Operation.....	7-21
Components of HVDC Lines.....	7-22
Converter Stations.....	7-22
DC Conductors.....	7-23
DC Reactors and Filters.....	7-23
Converter Transformers.....	7-23
AC Filters.....	7-24
Advantages and Disadvantages of HVDC Lines.....	7-24
<b>Module 7: Power Transmission Question Set.....</b>	<b>7-25</b>

## **Module 7: Power Transmission**

### **Table of Figures**

Figure 7.1: Transmission Line Components.....	7-6
Figure 7.2: Bundled Conductors.....	7-7
Figure 7.3 Insulator Disks.....	7-9
Figure 7.4: Loop Arrangement .....	7-11
Figure 7.5: Grid Arrangement.....	7-11
Figure 7.6: Transmission Line Model .....	7-12
Figure 7.7 Charging Requirements .....	7-15
Figure 7.8: Phase Angle Difference .....	7-17
Figure 7.9: Transposition Cycle.....	7-20
Figure 7.10: DC Transmission Line.....	7-21

## Power Transmission

### Module Overview

The **Power Transmission** module presents the following topics:

- Components and Interconnections
- Electrical Model
- Operating Considerations
- Circuit Restoration
- High Voltage Direct Current Transmission

You may recall reading in **Module 3: Power System Overview** that the transmission system is made up of high-voltage power transmission lines that transfer electricity from remote generating stations to customers. Some utilities use the term **transmission** to mean the power system backbone that ties together generation stations and primary substations. Regardless, transmission is designated to mean the higher voltage levels on a given power system.

We begin our discussion on power transmission with the components and interconnections of a transmission line.

### Section 7.1: Components and Interconnections

Utilities normally use overhead transmission lines for long distances and high voltages. Underground cables at high voltages are sometimes used for short distances but are substantially more expensive. A transmission line consists of:

- Conductors
- Towers
- Insulators
- Shield wires
- Rights-of-way

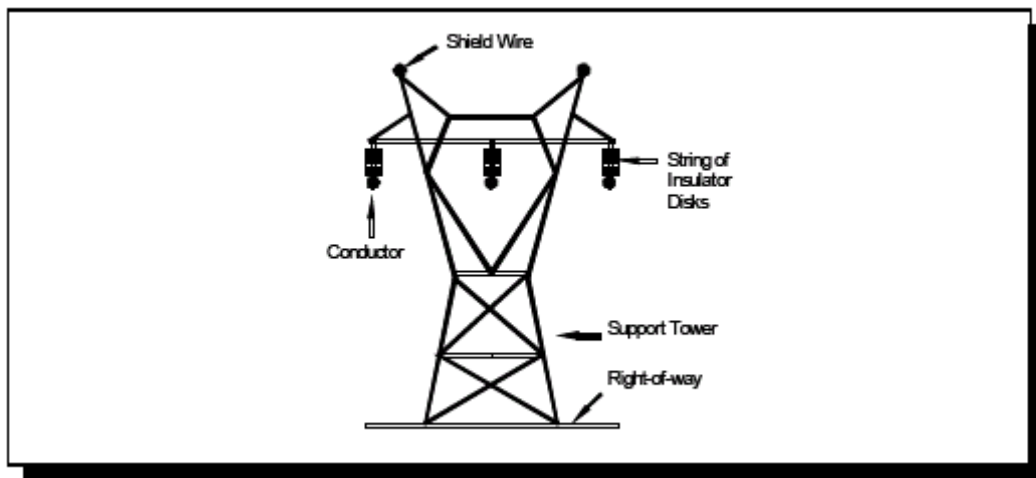
**Figure 7.1: Transmission Line Components**

We discuss each component individually, beginning with conductors.

## Conductors

Conductors carry the electricity. Transmission line conductors are made of copper, aluminum, or a combination of aluminum (or copper) and steel. The most common conductor material is an aluminum conductor, steel reinforced (ACSR). This is due to its light weight and low cost. ACSR conductors use a core of stranded steel wire surrounded by aluminum strands.

- The outer strands of aluminum carry most of the current.
- The inner strands of steel provide physical strength for the conductor.

Conductors can be solid or stranded. Most utilities use stranded conductors because they are more flexible.

All conductors are not capable of carrying the same amount of current. The ability to carry current depends on the ability to dissipate heat. A conductor's material and the size of the conductor determine the amount of current the conductor can carry. Although a copper conductor is capable of carrying more current than a similarly-sized aluminum conductor, aluminum is less expensive.

Utilities install underground high-voltage transmission cables much less frequently than overhead transmission lines. Unlike overhead lines that are insulated by air surrounding the conductors, buried cable must be insulated with other materials, such as oil, gas, or rubber. This increases the cost of cable. Insulation also limits the cable's current-carrying capability by limiting the size of the conductor.

**Definition: Corona**

**Corona** is a condition that occurs on conductors when the conductor's surface potential gets so high that the dielectric strength of the surrounding air is exceeded and ionization occurs. This condition is characterized by hissing sounds in the vicinity of the conductor and the appearance of glow points on the conductor. Power loss also increases and radio and television interference occurs in the vicinity of the line.

To keep electric field density low and thereby keep corona at low acceptable levels, utilities use conductors with a diameter as large as practical. One method of increasing the diameter is to use bundled conductors that have two or more conductors per phase.

**Figure 7.2: Bundled Conductors**

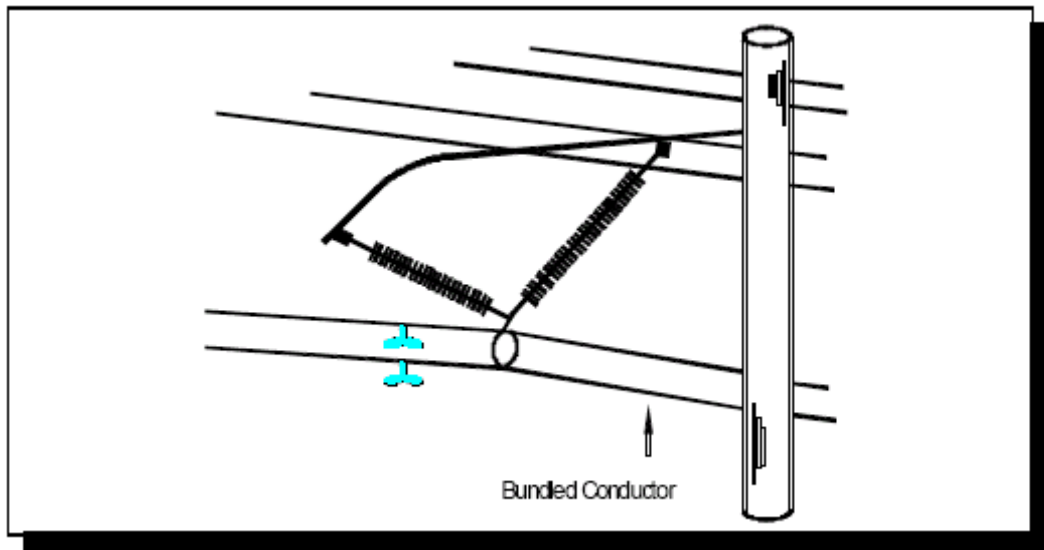

Bundled conductors also improve the power transfer capability of the line.

**Towers**

Transmission towers support high voltage transmission line conductors.

Tower design must ensure there is adequate clearance between:

- conductor phases
- conductor phases and the tower itself
- conductor phases and the ground and/or underlying objects such as vegetation or structures

The required clearances increase as transmission voltages increase. Therefore, towers for higher voltage lines are much larger and taller than towers for lines operated at lower voltages, such as distribution lines.

Tower structures are made of galvanized steel, aluminum, wood, or concrete and are set in concrete foundations.

### **Definitions: Span and Sag**

The distance between two towers, called a **span**, depends on the allowable sag. **Sag** is the amount the line droops at the span's midpoint.

## **Insulators**

### **Definition: Insulator**

**Insulators** are non-conducting devices that attach the energized conductors to the support tower. Insulators electrically isolate conductors from each other, as well as from the ground and support towers. The insulator must have sufficient mechanical strength to support the greatest loads reasonably expected due to ice and wind.

Insulators must withstand mechanical abuse (such as gunfire and thrown objects), lightning strikes, and power arcs without dropping the conductor.

Insulators prevent flashover under conditions of humidity, rain, ice, or snow; and with dirt, salt, smoke, and other contaminants accumulating on the surface.

Insulators are made of glass, polymer, or ceramic material. Most utilities use porcelain for insulators because it has excellent insulation properties and mechanical strength. Some utilities coat the porcelain with a glaze to provide a smooth surface from which contaminants can easily be washed by rainfall or wash sprays.

### **Definition: Leakage Distance**

Transmission line insulators consist of a string of insulator disks that are connected together and suspended from the support tower. Individual bell-shaped insulator disks increase the distance that an electrical arc has to travel to get from the energized conductor to the support tower. This distance is called **leakage distance**.

Each insulator disk has metal connectors on the top and bottom to allow individual disks to be connected into strings. Porcelain separates these connectors from each other to prevent short-circuiting the insulator.

The higher the voltage, the greater the number of individual disks required in each insulator string to maintain clearance.

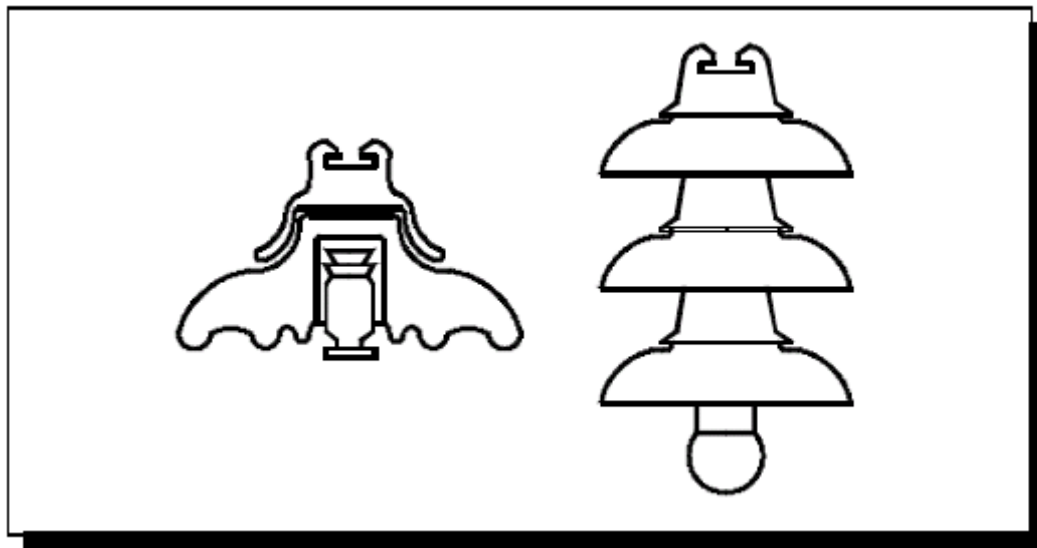
**Figure 7.3 Insulator Disks**

## Shield Wires

Shield wires, mounted at the top of the support tower, protect the energized conductors from lightning strikes. With conservative tower design, almost all lightning strikes to the transmission line hit a shield wire, instead of a line conductor.

Transmission lines require a conductive path from the shield wire to the ground to drain off electrical energy from the lightning strike to the ground.

- With a steel tower, the tower connects directly to the shield wire.
- With wood poles, ground wires run from the shield wire to the ground.

Sometimes the shield wires are also used for communications.

Refer to Figure 7.1 to see the placement of the shield wires.

## Rights-of-Way

### Definition: Rights-of-Way

**Rights-of-way** are the land over which one or more transmission lines pass.

Rights-of-way provide:

- Access to the line during construction and during subsequent line inspections, tests, and maintenance.
- Access to the vegetation (trees, brush, etc.) growing under the line to prevent it from growing up into the line and causing short circuits.

Rights-of-way must be wide enough to have adequate clearance between the transmission line and trees and buildings that are outside the right-of-way.

To have such access rights, utilities purchase or lease the land for rights-of-way.

Land that is available for rights-of-way that also provides a reasonably direct route to transmission substations may be difficult to acquire. As a result, rights-of-way are commonly shared by more than one line.

Now that we know the components of a transmission line, let's examine the different methods of arranging the transmission lines.

## Interconnection of Transmission Lines

The high voltage transmission system must be designed so that if one transmission line opens (that is, the line circuit breakers open):

- Major generating plants do not become separated from the rest of the power system and system instability, cascading outages, or voltage collapse do not occur.
- Customer service is not interrupted. A major transmission system outage would impact many customers.

To illustrate the problem, consider the looped power system shown in Figure 7.4.

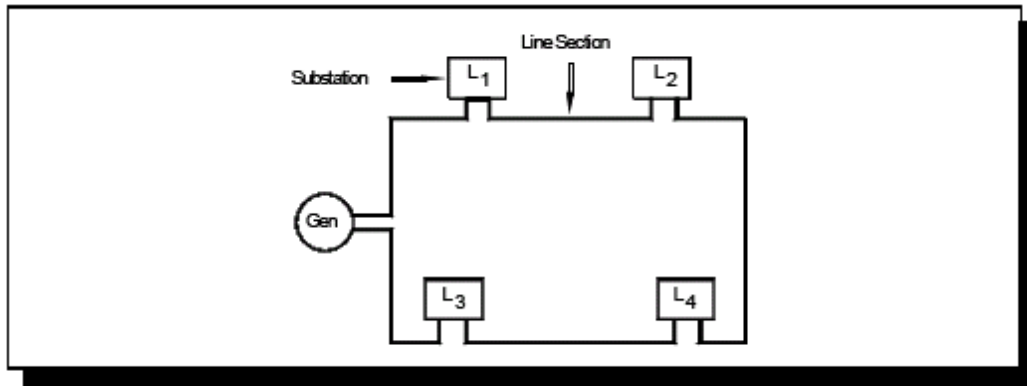
**Figure 7.4: Loop Arrangement**

In a loop arrangement, if any line section opens, all substations continue being fed.

The principle objective of transmission system design is to provide multiple transmission line paths between each generator and each load, so that no generation or load is lost if a transmission line trips.

One problem with the loop arrangement is that if a line section close to the generator opens, such as between the generator and L<sub>3</sub>, all power system load is fed through one path, which might overload a line section.

To avoid this problem, utilities use a transmission grid or network.

**Figure 7.5: Grid Arrangement**

Figure 7.5 shows two or more lines connecting each load. More interconnections between substations (loads) exist with the grid than in the loop design.

## Section 7.2: Electrical Model

In **Module 2: Fundamentals of Electricity**, we discussed the electrical parameters resistance, inductance, and capacitance. We are now ready to consider these parameters relative to a transmission line.

General equations relating voltage and current on a transmission line recognize that the parameters are evenly distributed along the line. Although we do not need to derive the equations, it is important to understand the impact of the parameters on the operation of the transmission system. To determine the design of a transmission line and perform other analysis functions, engineers model a transmission line in the following way:

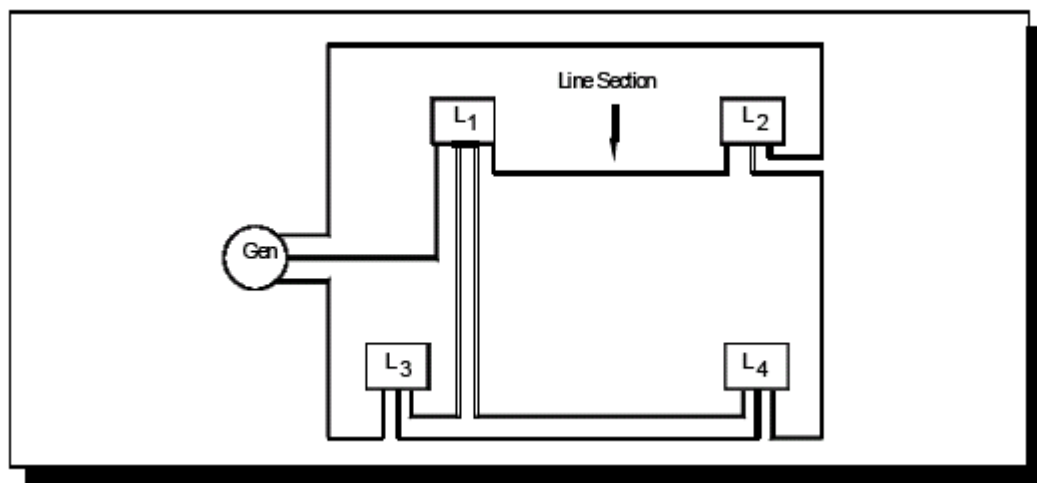
- A resistance ( $R$ ) and inductive reactance ( $X_L$ ) in series.
- A capacitive reactance ( $X_C$ ) in shunt.

**Figure 7.6: Transmission Line Model**

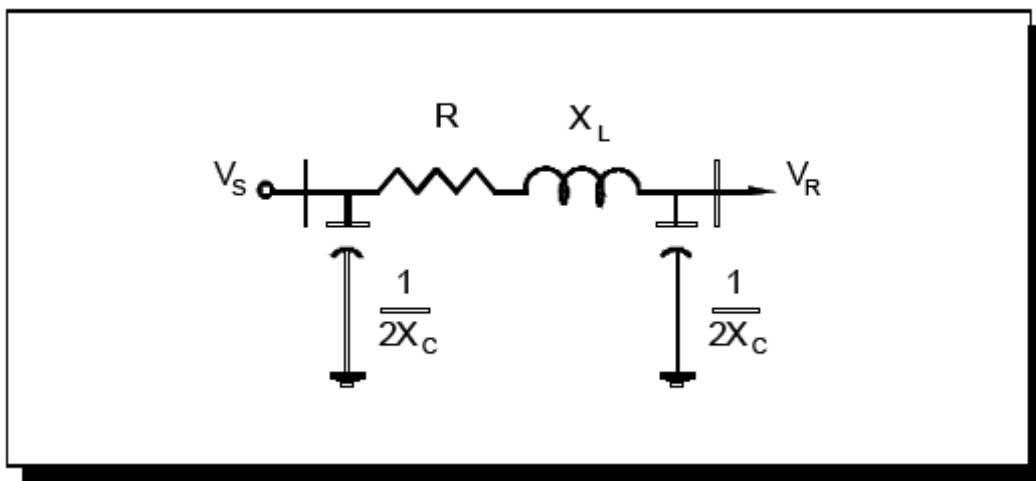

This model characterizes the transmission line. Different lines have different values for  $R$ ,  $X_L$ , and  $X_C$ , depending on the length, conductor cross sectional area, and spacing between the conductors. These parameters affect the current and power flow on the transmission line. We discuss the transmission line voltages,  $V_S$  and  $V_R$ , later in this module. But, before we can discuss these effects we need to look at each of the parameters beginning with resistance.

## Resistance

You may recall from **Module 2: Fundamentals of Electricity**, that resistance is the property of a material that opposes current by converting electric energy to heat and that real power (watt) losses occur due to  $I^2R$  heating. A transmission line's resistance is an important cause of power loss and is a function of the following:

- Conductor material: Copper has a lower resistance than aluminum.
- Conductor cross-sectional area: *Increasing* the conductor cross-sectional area decreases the resistance.
- Conductor length: *Increasing* the conductor length increases the resistance.

## Reactance

You may also recall from **Module 2: Fundamentals of Electricity**, that reactance is the name given to the opposition to current caused by capacitors and inductors and that there are also reactive power losses ( $I^2X$ ) when current flows.

- Inductors produce inductive reactance. The effect of inductive reactance is that the current lags the voltage.
- Capacitors produce capacitive reactance. The effect of capacitive reactance is that the current leads the voltage.

A transmission line's inductance and capacitance depend not only on the conductor's cross-sectional area and length, but also on the distance between phase conductors.

- The inductive reactance and capacitive reactance *decrease* as the conductor cross-sectional area *increases*.
- The inductive reactance and the capacitive reactance *increase* as the spacing between conductor's *increases*.

Because the space between high voltage conductors is large (to maintain safe clearance), the inductive and capacitive reactance is higher on high voltage lines than on distribution lines.

Capacitance exists between the conductors. It is the result of the potential difference between the conductors. The difference in potential causes the conductors to be charged in the same way the plates of a capacitor are charged. The capacitance between parallel conductors is constant depending on the conductor's size and spacing. Capacitance is far greater for underground cables, where the conductors and ground are very close. The capacitance produces reactive power.

For transmission lines less than 50 miles long, the effect of capacitance is very small and is usually neglected. However, for longer lines, the capacitance becomes increasingly important.

### **Definition: Charging Current**

Placing an alternating voltage on a transmission line causes the charge on the conductors to increase and decrease as the voltage increases and decreases. **Charging current** is the current that flows due to the alternate charge and discharge of the line due to the alternating voltage. Even when a transmission line is open-circuited at one end, charging current flows.

These parameters (resistance, inductance, and capacitance) combine to make up total impedance ( $Z$ ) and are fairly constant for a given transmission line.

So, what affect do they have on the power system?

## **Voltage and Power Flow**

A line's impedance, voltage level, and the voltage phase angle difference between the two ends of the transmission line determine the real power that can flow through a transmission line. So, to change the power flow, one or more of these elements needs to be changed.

As we now know, capacitance exists between the conductors of a line and between the conductors and ground. We also know that charging current flows on the line due to the alternate charging and discharging of the line due to the alternating voltage. When fully loaded, transmission lines absorb volt-amperes reactive (Var). At light loads, the capacitances of longer lines may become predominant and the lines become Var generators.

- If a line is lightly loaded, the capacitive charging current may exceed the load current. This results in the line operating with a leading power factor. Under this condition, the receiving-end voltage ( $V_R$ ) rises and may exceed the voltage at the sending-end ( $V_S$ ) of the line.

This voltage rise may over-stress insulation. The voltage regulating equipment at the receiving-end station may go out of range. This results in the customers receiving high voltage.

- If a line is heavily loaded, the receiving-end voltage ( $V_R$ ) drops below the sending-end voltage ( $V_S$ ).

The voltage drop may result in the voltage regulating equipment at the receiving-end station going out of range. This results in reduced customer voltage.

- When transmission lines have bundled conductors, the capacitance is greater than with single conductors. The increase in capacitance results in increased charging current. This capacitance acts as a Var generator. As voltage increases, the capacitive charging Vars of the line increase. The power system must absorb these Vars.

For example: a 200-mile 500-kV bundled transmission line requires approximately 320 Mvar of charging current.

**Figure 7.7 Charging Requirements**

<u>Voltage</u>	<u>Overhead 3Ø Charging (MVAR/mile)</u>	<u>Underground 3Ø Charging (MVAR/mile)</u>
500 kV	~ 1.6-2.0	~ 30.3
345 kV	~ .85	~ 17.0
230 kV	~ .30	~ 8.8
138 kV	~ .11	~ 4.9
115 kV	~ .07	~ 3.4
69 kV	~ .03	~ 1.9

This section discusses some of the undesirable effects of line impedance. Let's see what can be done to minimize these adverse conditions.

## Section 7.3: Operating Considerations

We will examine the methods of controlling real power flow, then look at the methods for controlling voltage and reactive power flow.

### Controlling Real Power Flow

We discussed in the previous section that the real power flow is determined by:

- the angle difference of the voltages at the terminals
- the voltage level of the line
- the impedance of the line

The real power flow between two buses is obtained from the following equation:

$$P = \frac{V_s V_r}{X} \sin \phi$$

Where:

P = Real power in MW

$V_s$  = Sending-end voltage

$V_r$  = Receiving-end voltage

X = Reactance of the line between sending and receiving ends (the impedance is mostly made up of reactance)

$\Theta$  = Angle between  $V_s$  and  $V_r$  (bus voltages)

Any method of increasing real power flow must address the variables in the equation. This is accomplished by using one of the following methods:

- changing the phase angle with phase shifting transformers
- changing generation patterns relative to the line terminals
- changing the impedance of the line with series capacitors

Conversely, decreasing real power flow can be accomplished by decreasing the phase angle with phase shifting transformers, or increasing line impedance by switching out series capacitors.

Let's briefly examine each of these methods of controlling real power.

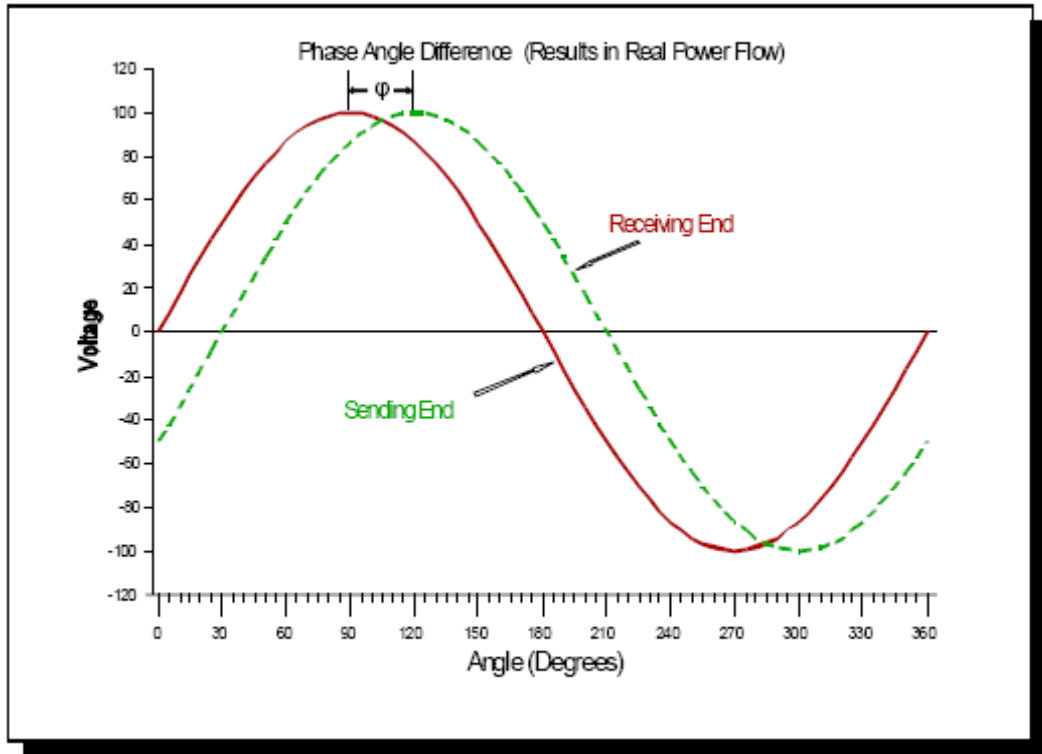
**Figure 7.8: Phase Angle Difference**

### ***Phase Shifting Transformers***

You may recall from reading ***Module 6: Transformers***, that phase shifting transformers redistribute real power flow between parallel lines by changing the voltage phase angle across the line being controlled.

### ***Series Capacitors***

Series capacitors cancel some of the inductive reactance of the line, therefore decreasing impedance. This enables more real power to flow.

Utilities use series capacitors primarily to improve system stability. We discuss stability in more detail in ***Module 9: Principles of Power System Operation***.

Now let's examine the methods for controlling voltage and reactive power flow.

## Controlling Voltage and Reactive Power Flow

Reactive compensation methods alleviate some of the undesirable effects of line charging. Reactive compensation methods include installing shunt reactors and capacitors on the lines, transposing conductors, and running synchronous generators and condensers. In essence, reactive power compensation methods cancel a portion of the line charging.

In general, the following elements are sources of reactive power (Vars):

- overexcited generators and synchronous condensers
- shunt capacitors
- line capacitance

In general, the following elements absorb or use reactive power:

- underexcited generators and synchronous condensers
- shunt reactors
- line transformers
- motor loads

## Shunt Reactors

As we discussed earlier, during light loads the capacitive charging current may cause excessive voltage at the receiving end of a transmission line.

Switching shunt reactors in-service compensates for this effect by adding Var load to the system.

A shunt reactor is an inductor that is connected line-to-ground. Since an inductor is a conductor formed in a coil, the coil produces a magnetic field that requires Vars. The shunt reactor absorbs excess Vars supplied by transmission lines. Shunt reactors are also connected to the tertiary windings of a transformer bank.

Utilities switch shunt reactors in service to absorb excess Vars during lightly loaded periods.

## Shunt Capacitors

As you know, if a line is heavily loaded, the inductive Var losses may cause insufficient voltage at the receiving end of a transmission line. Shunt capacitors compensate for this effect.

Utilities switch shunt capacitors in and out of service to meet peak load demands.

- In the morning when customer load is increasing, capacitors are switched in-service (sometimes automatically) to supply Vars to the system.
- In the evening when customer load is dropping off (and the Var demand is reduced), the capacitors are switched out of service.

Switching shunt capacitors on will supply Vars to the system; therefore increasing the voltage. Shunt capacitors are normally installed as close to the load as practical.

Another device that has the ability to control voltage is a static Var compensator (SVC). An SVC is a system of capacitors and reactors controlled with solid-state electronic devices to provide a rapidly controllable source of reactive power. SVCs are located at transmission substations to provide support and increase stability to the power system.

## Generators

During light load periods, generators may have to run underexcited; the generator absorbs Vars from the power system. As you may recall from reading **Module 4: Principles of Power Generation**, this can lead to instability.

During heavy load periods, generators may be run overexcited; supplying Vars to the system. Generators can normally supply more reactive power than they can absorb.

## Transposing Conductors

The amount of symmetry in the positioning of the conductors also affects line reactance.

- If phase conductors are symmetrically arranged, the series and shunt reactance of each phase are the same for each conductor.
- In most cases, conductors are not symmetrically spaced.

For example: The three phase conductors are frequently arranged in a horizontal line. Impedances are somewhat different for each phase. As a

result, current flow on each phase is not balanced. That is, more current flows on the conductor with the lowest impedance.

- To minimize this effect, utilities use a method called transposing the conductors.

**Figure 7.9: Transposition Cycle**

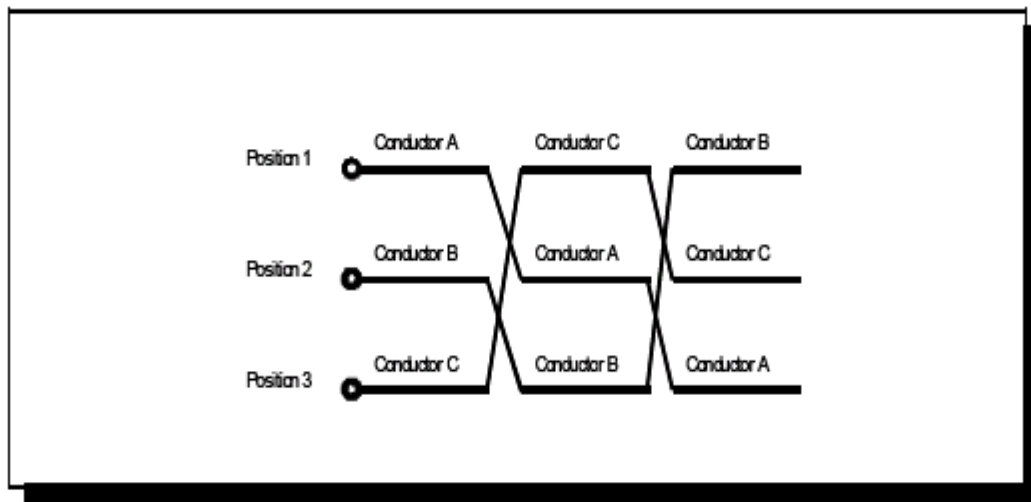

Figure 7.9 shows the exchanging of conductor positions at regular intervals so that each conductor occupies each possible position for an equal distance. This helps to balance the series and shunt reactance.

## Section 7.4: Circuit Restoration

Most transmission line faults are temporary. That is, whatever causes the fault usually burns off. Therefore, in most cases the line can be safely re-energized.

### **Definition: Reclosing**

**Reclosing** is the process of automatically re-energizing a line that opens due to a fault. Most transmission line circuit breakers automatically reclose after opening to clear a fault.

To restore a line to service, most utilities first reclose the circuit breakers at one end of the line to energize the dead line up to the open breaker at the opposite end.

### Definition: Synchronism Checks

Before reclosing the circuit breakers at the opposite end of the line, utility personnel or special relay equipment perform **synchronism checks**, commonly called sync checks. Sync checking determines whether the voltage phase angle or voltage magnitude across the breaker differs by more than a pre-specified amount.

It is possible that the voltages on either side of these open breakers are different in magnitude and somewhat out of synchronism. This is because the two sides of the breaker may be fed from widely separated voltage sources. The two sides of the breaker may also be operating at different power system frequencies. Tying two portions of the power system that are not synchronized could result in serious power swings that could threaten power system stability.

To prevent such problems, personnel adjust voltages and generation levels on either side of the open point so that frequencies exactly match and voltage phase angle and magnitude differences are within acceptable tolerances.

## Section 7.5: High Voltage Direct Current

You may recall from reading **Module 3: Power System Overview**, that some utilities use high-voltage direct current (HVDC) transmission lines, operating in the 500-kV to 1000-kV range. The voltages used here are line-to-line voltages and 1000 kV refers to  $\pm 500$  kV as shown in the diagram below.

Let's examine how HVDC transmission lines operate.

### Principle of Operation

Figure 7.10: DC Transmission Line

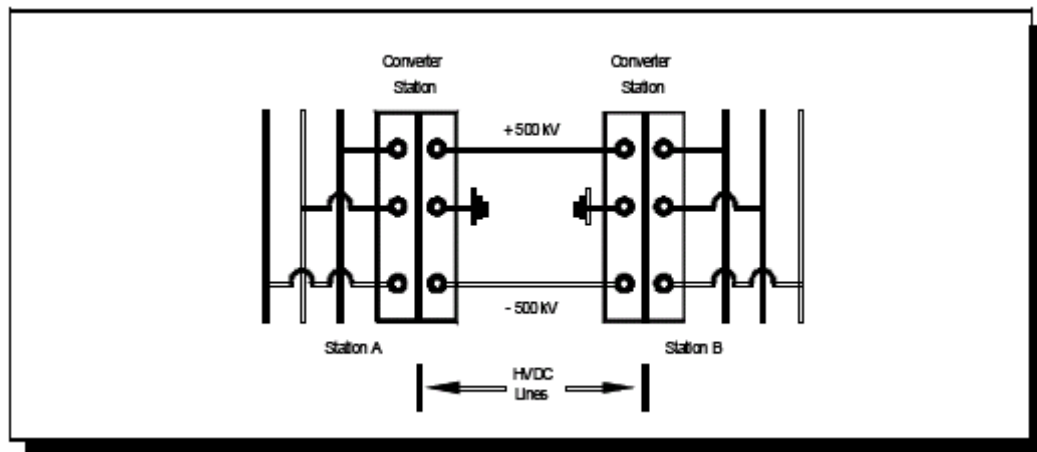

Figure 7.10 illustrates the following:

- For power flow from Station A to Station B, the converter station at Station A rectifies alternating current to produce direct current.
- Direct current flows over an HVDC line to Station B.
- The converter station equipment at Station B inverts to change the direct current back to alternating current.
- AC power leaves Station B.

An HVDC line can transfer power only in the direction for which it is configured at a given time. Before power can flow from Station B to Station A, the operation of the rectifier-inverter equipment at both stations must be reversed.

The HVDC line can only transfer power between two energized AC power systems. It is not possible to send power over the HVDC line to a dead AC power system.

Now, let's discuss some of the components of the HVDC system.

## Components of HVDC Lines

The principle components of HVDC lines are:

- Converter Stations
- DC Conductors
- DC Reactors and Filters
- Converter Transformers

We discuss each of these components in the next few pages.

### ***Converter Stations***

#### **Definition: Converter Bridge**

HVDC lines require a converter station, also called a ***converter bridge***, at each end of the line.

- The station at the line's sending end is the rectifier.
- The station at the line's receiving end is the inverter.

**Definition: Valves**

The converter stations contain devices called **valves**. The valves perform the rectification or inversion. The name comes from the mercury-arc valves used in older HVDC lines. Modern lines use electronic devices, called thyristors.

Like an electronic diode, valves conduct electricity in one direction only. However, unlike a diode, valves conduct electricity only when they receive a control signal.

By adjusting the timing of the control signals, the converter station at either end can be a rectifier or an inverter. The timing of the control pulses can also adjust the line voltage and shut down the line.

**DC Conductors**

HVDC lines have two conductors: one positive pole and one negative pole.

- One conductor operates at a positive voltage (with respect to ground) equal to one-half the line-to-line voltage.
- The other conductor operates at a negative voltage (with respect to ground) equal to one-half the line-to-line voltage.

Under normal conditions, very little current flows through the ground. During abnormal conditions, the HVDC line can operate at reduced capacity.

- Only the positive or negative conductor is in service. The ground (either metallic or earth) serves to complete the circuit.
- Operation using earth return must be limited since electrolysis in buried metallic objects, such as pipelines, can occur.

**DC Reactors and Filters**

The converter station produces a DC waveform that is fairly choppy (has ripples). Reactors connected to the DC conductors at each end of the line smooth out this waveform. Installation of series reactors can limit fault current flow on the line.

**Converter Transformers**

At each end of the DC line, a load-tap changing transformer connects the converter stations to the AC system.

## **AC Filters**

The converter station produces harmonic currents. Harmonic currents alternate at frequencies higher than 60 Hz (usually multiples of 60 Hz). Current harmonics can cause unnecessary heating on circuit elements since the equipment is not designed to operate at frequencies other than 60 Hz. Capacitors combined with reactors form filters to eliminate the harmonics.

## **Advantages and Disadvantages of HVDC Lines**

Electric power transmission using direct current has some advantages over AC power transmission, including:

- AC losses associated with series inductance and lines charging due to capacitance are eliminated. It is therefore possible to use overhead lines and underground cables for HVDC power transmission over long distances.
- HVDC lines require only two power conductors rather than the three required for AC lines.
- HVDC lines can tie together two power systems having dissimilar characteristics.

For example: HVDC lines can tie a power system operating at a frequency of 50 Hz to a system operating at 60 Hz.

### **Definition: Modulation**

Rapid adjustments, called **modulations**, to power flow on DC lines can be made. During AC power system swings, the HVDC line loading can be modulated to dampen the swing and help maintain AC system stability.

The primary disadvantage of HVDC transmission lines is the high cost of the terminal equipment at each end of the line and the high cost for associated maintenance.

HVDC lines generally become more economical than AC lines if:

- The line length of overhead portions exceeds 400 miles.
- The line length of underground cable portions exceeds 25 miles.
- A special circumstance, such as a tie between two dissimilar power systems, exists. Utilities use back-to-back DC installations for this function. With this type of DC installation, the rectifier and the inverter are installed in the same location. Several back-to-back installations currently exist between WECC and other regions.

**Conclusion:** This concludes the power transmission module. The purpose of the module is to discuss a transmission line's supporting structures and electrical design characteristics. We also discuss the operation of HVDC systems. You should review the methods for controlling voltage and power flow available at your utility.

**Module 7: Power Transmission  
Question Set**



- 7.2** An electrical model of a transmission line consists of three circuit elements:
- (a)** resistance, inductive reactance, and capacitive susceptance in series
  - (b)** A resistance and **inductive** reactance in series; A capacitive reactance in shunt
  - (c)** An inductive reactance and capacitive susceptance in series; A resistance in shunt
  - (d)** A capacitive **reactance** in series; A resistance and inductive reactance in shunt
- 7.3** True/False: Copper has a higher resistance than aluminum.
- 7.4** True/False: Increasing the conductors' cross-sectional area decreases the resistance.
- 7.5** True/False: Increasing the conductor length decreases the resistance.
- 7.6** What is charging current?
- 7.7** During light load periods, the receiving-end voltage may **exceed/drop below** (circle one) the sending-end voltage.

**7.8** List the three variables that determine the real power that can flow through a transmission line.

**7.9** Describe the effect of inserting series capacitors on a transmission line.

**7.10** List three sources of reactive power (Vars).

**7.11** List four power system elements that absorb or use reactive power (Vars).

**7.12** What is the purpose of transposing conductors?

**7.13** Define reclosing.

**7.14** What is a sync check?

**7.15** List two advantages of using direct current instead of alternating current for power transmission.

**7.16** What is the purpose of a back-to-back DC installation?

This page intentionally left blank.



**Module 8:  
System Protection**

This page intentionally left blank.

## Module 8: System Protection

### Table of Contents

<b>System Protection .....</b>	<b>8-5</b>
<b>Section 8.1: Purpose of Protection Systems.....</b>	<b>8-5</b>
Causes of Faults .....	8-5
<b>Section 8.2: Characteristics of Protection Systems .....</b>	<b>8-7</b>
Components of Protection System: .....	8-7
(1) Measuring Devices .....	8-7
(2) Protective Relays.....	8-10
(3) Control Circuitry.....	8-11
Protection Zones .....	8-12
Back-Up Protection .....	8-13
<b>Section 8.3: Types of Relay Devices and Applications .....</b>	<b>8-14</b>
Line Protection Systems.....	8-14
Distribution Feeder Protection Systems.....	8-14
Transmission Line Protection Systems.....	8-17
Types of Transmission Line Protection .....	8-18
(1) Directional Overcurrent Relaying .....	8-18
(2) Distance Relaying .....	8-19
(3) Pilot Schemes.....	8-22
Transfer Tripping.....	8-23
Directional Comparison .....	8-24
Phase Comparison.....	8-25
Pilot Wire .....	8-26
(4) Out-of-Step Relaying .....	8-27
(5) Single Pole Relaying.....	8-28
Substation Equipment Protection Systems .....	8-29
Shunt Equipment Protection .....	8-29
Bus Protection .....	8-30
Transformer Protection .....	8-30
Circuit Breaker Failure Protection .....	8-31
Underfrequency Load Shedding .....	8-32
Generator Protection Systems .....	8-32
Winding Differential Protection.....	8-32
Ground Fault Protection System.....	8-33

Detection of Unbalanced Faults .....	8-33
Overload Protection .....	8-33
Loss-of-Excitation Protection.....	8-33
Generator Motoring Protection .....	8-34
Generator Protection at Reduced Frequencies .....	8-34
Remedial Action Schemes.....	8-35
<b>Module 8: System Protection Question Set .....</b>	<b>8-37</b>

### Table of Figures

Figure 8.1: Current Transformer.....	8-8
Figure 8.2: Coupling Capacitance Voltage Transformer.....	8-9
Figure 8.3: Electromechanical Time Overcurrent Relay .....	8-10
Figure 8.4: Protection Zones .....	8-13
Figure 8.5: Fuse and Overcurrent Relay Characteristic Curves .....	8-15
Figure 8.6: Relay Coordination with Fuses.....	8-17
Figure 8.7: Coordinating Overcurrent Relays .....	8-18
Figure 8.8: Electrical Distance.....	8-20
Figure 8.9: Zones of Distance Relays .....	8-21
Figure 8.10: Pilot Schemes .....	8-22
Figure 8.11: Permissive Overreaching Transfer Trip.....	8-24
Figure 8.12: Directional Comparison .....	8-25
Figure 8.13: Bus Protection.....	8-30
Figure 8.14: Generator Frequency Trip Settings .....	8-35

# System Protection

## Module Overview

The **System Protection** module presents the following topics:

- Purpose of Protection Systems
- Characteristics of Protection Systems
- Types of Relay Devices and Applications

## Section 8.1: Purpose of Protection Systems

First, we discuss what a protection system is and what it is designed to do. Then we examine how a protection system operates. The primary purpose of the protection system is to detect faults and, as rapidly as possible, "clear" faults.

### Definition: Fault

**Faults** are physical conditions that cause a device, component, or element to fail to perform in the required manner; for example, a short circuit or a broken wire. Short circuits occur between energized power system components and either of the following:

- Objects that are not normally energized (such as trees, cars, transformer and circuit breaker cases).
- Power system components that are energized at a different voltage, such as primary distribution conductors contacting secondary distribution conductors or phases contacting other phases of the same line (called a phase-to-phase short circuit).

## Causes of Faults

Some of the common causes of faults are:

- A tree limb comes in contact with an energized overhead wire.
- An overhead wire breaks due to snow or ice loading, or because a car strikes the utility pole causing the wire to come in contact with the ground.

- Power system components such as circuit breakers or transformers malfunction; or the insulation fails due to wear, age, or repeated operations.
- Lightning strikes an overhead wire, either causing physical damage or creating charged air molecules that serve as a path on which fault current can flow.

As you can see, electric systems are subjected to a variety of abnormal conditions that can create faults. To minimize service interruption and damage to the equipment, the fault must be detected and the faulted equipment disconnected from the power system as soon as possible.

This is the function of the protection system.

The protection system clears faults by initiating control actions (i.e., opening appropriate circuit breakers and disconnect switches) to electrically isolate the faulted equipment from the rest of the electric system.

Rapid operation of the protection system accomplishes the following:

### **Maintains Safety**

Maintains Personnel and Public Safety. A downed wire that has not been electrically isolated is still energized. This presents a safety hazard to people who may attempt to move it or who inadvertently contact it.

### **Prevents Damage**

Prevents More Extensive Damage. Short circuit currents during faults are many times the normal load currents. If the flow of the current is not interrupted quickly, components of the electric system may be damaged. In addition, some faults can cause over-voltages that exceed the rating of the insulation of some components, resulting in further damage to the equipment. The overvoltages are usually transient and are produced from simple circuit changes, such as a circuit breaker opening or the grounding of a conductor.

### **Prevents Stability Problems**

Prevents Power System Stability Problems. Faults that remain on high-voltage transmission equipment or on generators can cause system stability problems. Power system stability is discussed in more detail in ***Module 9: Principles of Power System Operation***.

Now we know why we need protection systems for electric system equipment and can begin our discussion of the characteristics of protection systems.

## Section 8.2: Characteristics of Protection Systems

The circuit breakers or fuses found in every household are simple examples of protection systems. Electric faults in the house are fairly common occurrences. These occur from frayed lamp cords or when you replace a light switch without turning the power off. On these unpleasant occasions, the household protection system detects an abnormally high current flow and a circuit breaker opens or a fuse blows.

Protection systems on power systems are much more complex than in the household example, but their purpose is the same.

In this section, we present information about the components of protection systems and some basic concepts about protection systems.

Protection systems have three major components:

- 1) Measuring Devices
- 2) Protective Relays
- 3) Control Circuitry

We discuss each of the three components of a protection system in the next few pages, beginning with measuring devices.

### **Components of Protection System: (1) *Measuring Devices***

Most protection systems analyze power system current flow and/or voltage to determine whether a fault exists. Sudden changes in these quantities could indicate that a fault exists.

For example: either a sudden increase in current flow to many times the normal load current, or a significant increase or decrease in line voltage could indicate that a fault exists somewhere.

The protection system cannot directly use the voltage and current measurements from the high-voltage equipment as inputs. Therefore, these values must be scaled down.

The following devices perform this function:

- current transformers (CTs)
- voltage transformers (PTs)
- coupling capacitance voltage transformers (CCVTs)

**Definition: Current Transformer (CT)**

Power system current is measured by **current transformers**; commonly called CTs. CTs reduce or scale down the actual current to proportional values of a few amperes for use by the protection system.

Most CTs are donut-shaped and are installed over the bushings of power transformers, circuit breakers, or generators. Figure 8.1 is a diagram of a CT inside a bushing.

**Figure 8.1: Current Transformer**

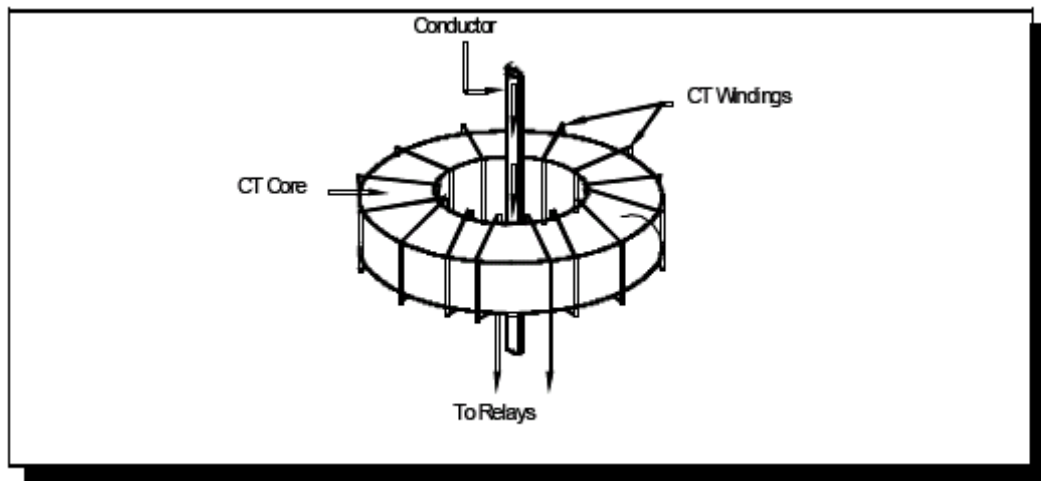

You may recall from reading **Module 2: Fundamentals of Electricity**, that when current flows in a conductor it produces a magnetic field (flux) around the conductor. Similarly, the primary current flowing to the breaker or transformer through its bushing causes a changing magnetic flux in the CT core. The flux induces a secondary current of a few amperes in the CT windings. This current then flows over the CT leads to the relays. **Module 6: Transformers**, describes how a transformer operates. The CT winding supplies the low current to the relays.

The secondary circuit of an energized CT must never be opened. Instead, CT secondary circuits should be shorted, and then devices on the load side of that transformer may be opened. The circuit continuity is maintained back to the secondary.

In voltage terms, the CT is a "step-up" transformer. That is, the turns ratio (perhaps 2500:1) is such that current is reduced and voltage is increased. However, the CT must still obey Ohm's Law ( $V = IR$ ). With normal low-impedance loads (relays or meters), the "IR" term is very small so the voltage is low. Shorting the secondary leads before removing the load keeps "IR" very low. Conversely, open secondary leads result in very high impedance across the open points. The primary (load) current continues to flow—exciting the secondary winding.

Extremely high voltages are induced and can cause electrical shock and injury to personnel and destroy the control circuitry.

### Definitions: Voltage Transformers and Coupling Capacitance Voltage Transformers (CCVTs)

Power system voltage is measured either by **voltage transformers** or **coupling capacitance voltage transformers (CCVTs)**, depending on the voltage level being measured. Both devices reduce electric system voltage down to proportional values of 120 volts or less.

Voltage transformers are simple magnetic core, wire-wound transformers. They are usually referred to as PTs, short for potential transformers. PTs operate in the same way as step-down power or distribution transformers (see **Module 6, Transformers**).

### Definition: Coupling Capacitance Voltage Transformers (CCVT)

At voltage levels of 100 kV or higher, the cost of PTs becomes very high. At these voltage levels, therefore, CCVTs are typically used. A CCVT is a stack of capacitors connected between the points of voltage measurement. The desired 120 voltage level is obtained by voltage division, as shown in Figure 8.2.

**Figure 8.2: Coupling Capacitance Voltage Transformer**

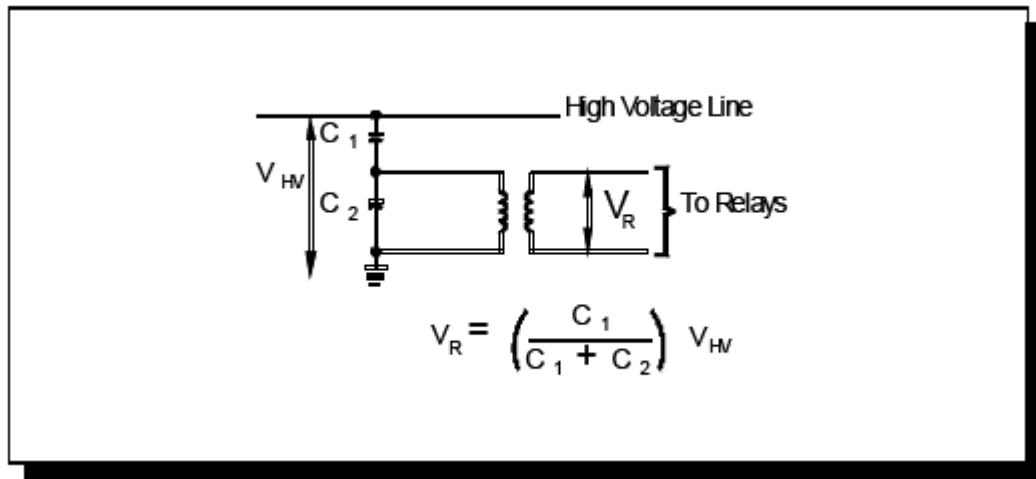

The accuracy of CCVTs is less than that of PTs. CCVTs may not be acceptable, where high accuracy is required, such as for billing or metering functions.

## **Components of Protection System: (2) Protective Relays**

### **Definition: Protective Relays**

**Protective relays** are protection system devices which compare power system voltages and currents to normally-expected values to determine whether the protected device has a fault.

The earliest types of protective relays, many of which are still in use today, were built using electromechanical components, such as gears, springs, mechanical timers, and induction disks.

**Figure 8.3: Electromechanical Time Overcurrent Relay**

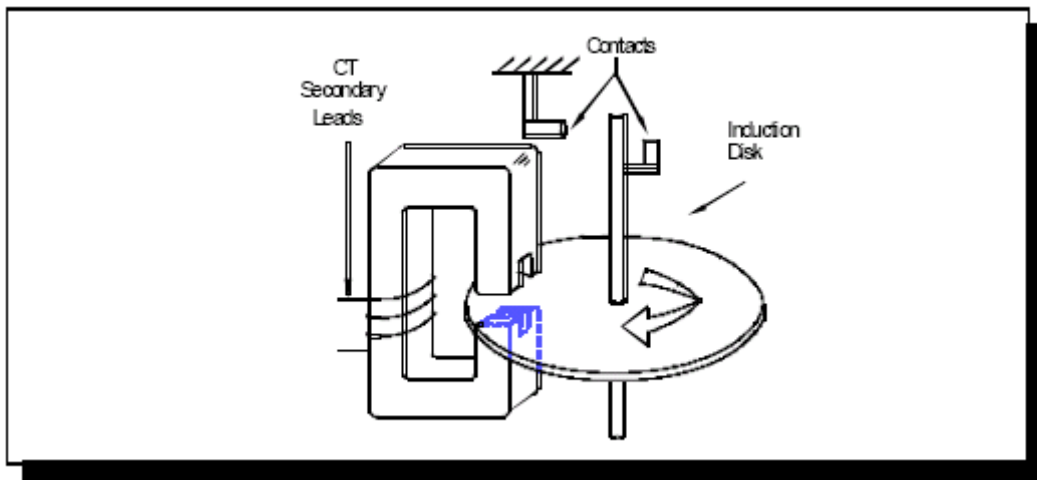

A time overcurrent relay operates if an abnormally high current exists for a predetermined period of time. This relay looks and operates like your household watt-hour meter.

### **Definition: Pick-Up**

- Currents above a specified minimum operating level, called the ***pickup***, cause the induction disk to rotate. Unlike the disk of a watt-hour meter, the relay's induction disk turns only far enough to close the relay contacts.
- The disk keeps turning as long as the pickup current exists. The greater the current, the faster the disk turns.

**Definition: Target**

- If the fault stays on long enough, the turning causes the contacts mounted on the disk to touch the contacts mounted on the frame of the relay, completing a trip circuit. An indicator, called a **target**, is displayed when the relay operates. The target remains displayed until it is manually reset.
- If the fault current is removed (cleared) before the trip circuit is completed, the disk stops turning and a spring returns the disk to its starting position.

Though many utilities continue to use electromechanical relays, manufacturers have introduced new designs. Over the past 20 years or so, utilities have been using "static" relays that are built using transistors and other electronic components.

More recently, relays which use microprocessors have been introduced. Microprocessor relays are computer-based and have several advantages over the electromechanical and static counterparts, including:

- **Perform Self-Diagnosis:** Microprocessor relays can generate an alarm to warn maintenance personnel that a possible problem exists, so repairs can be performed before the relay is called upon to operate. With electromechanical and static relays, problems are discovered during periodic inspections or when the relays fail to operate when faults occur.
- **Occupy Less Space on Control Panels:** Microprocessor relays typically perform the functions of several traditional relays, and therefore take up less overall space on the control panel.
- **Perform Advanced Functions:** Microprocessor relays can provide information on fault location and can store fault data for analysis.

We present other types of relays and their applications later in this module.

***Components of Protection System: (3) Control Circuitry***

The third component of the protection system is the control circuitry. The control circuitry includes control wiring, switches, batteries, and other equipment needed to operate substation breakers to isolate the fault.

The control circuitry is activated after the relays determine that a fault has occurred. The control circuitry sends a signal to the trip coil that opens the appropriate circuit breakers to isolate the faulted equipment from the rest of the power system.

In addition to the three parts of a protection system we have discussed, utilities use two protection systems concepts:

- Protection Zones
- Back-Up Protection

## Protection Zones

One protection system cannot protect an entire electric system. Rather, each protection system is designed to handle one protection zone.

### Definition: Protection Zone

A **protection zone** is a portion of the power system that can be isolated electrically from the rest of the system by opening circuit breakers or switches if a fault occurs in that zone.

Typical protection zones may be a substation bus, a transformer, a distribution feeder, a transmission line, or a generator. Each zone includes the associated circuit breakers.

The primary purpose of each protection system is to detect and isolate faults in a single protection zone.

### Definitions: Internal Faults and External Faults

- Faults within the protection zone are called **internal faults**.
- Faults outside the protection zone are called **external faults**.

Figure 8.4 shows the system connections for protected zones on a generator, bus, and two lines (dotted lines represent protection zone boundaries).

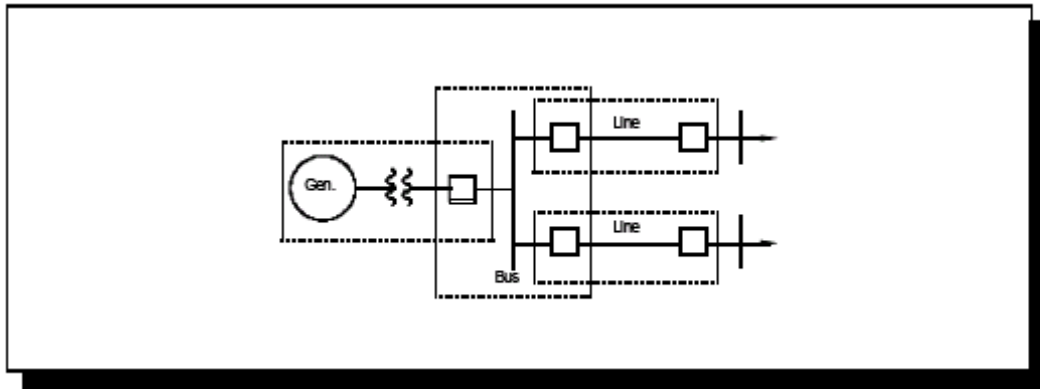
**Figure 8.4: Protection Zones**

You can see from Figure 8.4 that each zone overlaps adjacent zones. This avoids the possibility of unprotected areas. However, a protection zone should include as few power system elements as practical.

## Back-Up Protection

Like any other system, protection systems do occasionally fail to perform. Failure to properly clear a fault is extremely dangerous. (Reasons for avoiding protection system failure are listed in the Purpose section of this module.)

The protection system's failure to perform may be caused by a malfunction of any of the following:

- measuring devices
- relays
- control circuitry
- breaker electrical or mechanical components

Arrangements must be made to clear the fault, even if the primary protection system fails. Back-up protection accomplishes this.

One form of back-up protection is inherent in the protection system itself. Most protection systems are able to "detect" faults in an adjacent protection zone and trip their associated breakers if the fault is not cleared within a specified time period.

However, the time delay associated with this form of back-up protection cannot be tolerated on critical high-voltage lines and generators. These facilities frequently are equipped with two or more independent protection systems, so that if one protection system fails the second system is still available to detect and isolate faults without unnecessary delay.

Protection system malfunction due to the breaker's electrical or mechanical components is a special case that is covered by breaker failure protection schemes (we discuss these later in this module).

Now that we know the purpose and characteristics of protection systems, we can examine types of relay devices and their applications.

## **Section 8.3: Types of Relay Devices and Applications**

In this section we describe some commonly-used protection system schemes. The protection systems are grouped according to the equipment protected, as follows:

- Line Protection Systems
- Substation Equipment Protection Systems
- Generator Protection Systems

In addition to the protection systems for the various types of equipment, we also examine one special relay application, remedial action schemes.

### **Line Protection Systems**

Protection systems requirements for transmission lines are different from those required for distribution feeders. Therefore, line protection is presented in two parts:

- Distribution Feeder Protection Systems
- Transmission Line Protection Systems

#### ***Distribution Feeder Protection Systems***

Distribution feeders are subjected to a variety of faults, including those due to wind, lightning, tree limbs, and equipment failures. These faults may be transient or may be permanent. If the fault is transient, fast clearing minimizes the damage and may prevent the fault from becoming permanent.

Fuses generally isolate faulted portions of distribution feeders. Current passes through a metallic strip in the fuse. If the current exceeds a set value for a predetermined time period, the metallic strip in the fuse melts ("blows") and, consequently, opens up the circuit. The time that must pass for the fuse to blow depends upon the amount of current flow.

The fuse blows:

- quickly for high currents
- slowly for low currents

### Definition: Characteristic Curve

Figure 8.5 shows what is called a **characteristic curve**, a plot of the time-to-blow versus current flow for a typical fuse and overcurrent relay. Similar characteristic graphs are available for all protection relays. For now, we will focus on the fuse's curve. A wide variety of fuses, having differently-shaped characteristic curves, are available to fit many situations.

**Figure 8.5: Fuse and Overcurrent Relay Characteristic Curves**

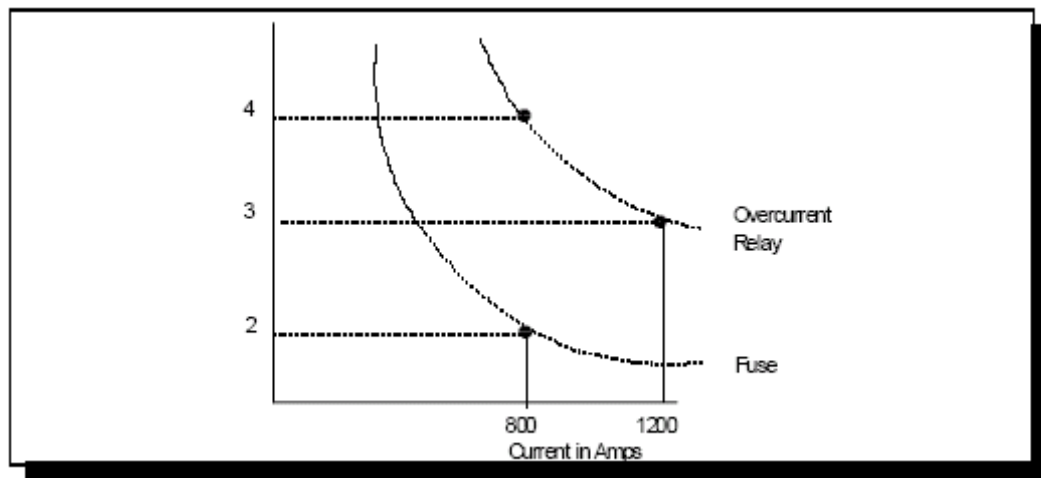

Figure 8.5 shows the following:

If a fault current of 800 amperes is flowing, the fuse blows in 2 seconds. For higher fault currents, the fuse blows sooner. The time-to-operate increases significantly as the current decreases.

Typically, a set of fuses is installed where a feeder branches off the main feeder, to go down a street, for example. If a fault occurs along the street, the branch fuse blows, interrupting power only for the customers on that street. Normal operation continues for other customers on the feeder.

At the substation, each distribution feeder has a circuit breaker that opens to remove power from the entire feeder. The circuit breaker has a protection system for the feeder, which trips the breaker if a feeder fault is detected.

Most distribution feeders are protected by overcurrent protection systems, based on time overcurrent protective relays. The relay operating time varies depending on the fault current magnitude. For high currents, the relay operates with little or no delay. The time delay before operating increases as fault current decreases (refer to Figure 8.5).

In some situations, it may be desirable to allow the feeder breaker to reclose quickly once or twice so if the fault is temporary, a longer outage can be avoided.

**Definition: Pickup**

The minimum current at which the relay operates is called the ***pickup***. For currents that are just above the pick-up, the time-to-operate is very long. If current is below the pickup, the relay does not operate.

**Definition: Instantaneous Setting**

An ***instantaneous setting*** is a predetermined value of fault current above which some overcurrent relays operate "instantaneously" (with no time delay).

The overcurrent protection system must be coordinated with branch line fuses. For the times when faults occur on the feeder branch, the feeder overcurrent relays must delay enough to allow the feeder branch fuse to blow before the feeder relay operates and trips the entire feeder.

The example shown in Figure 8.6 illustrates the process of coordinating distribution overcurrent relays with feeder branch fuses. Refer to Figure 8.5 for the fuse and breaker characteristic curves related to this example.

In areas that experience many temporary faults, some utilities prefer to trip the feeder breaker before the fuse has time to blow. If the fault has cleared by the time the breaker closes, an extended outage has been avoided. If not, the tripping of the breaker is delayed to allow the fuse to blow.

**Figure 8.6: Relay Coordination with Fuses**

Figure 8.6 shows the following:

- For a fault located at Point A, 1200 amperes of fault current flow through the feeder overcurrent relay. By looking at the characteristic curve for the relay (shown in Figure 8.5), we see that the feeder overcurrent relay operates in 3 seconds to clear the fault. This kills the entire feeder. Since the fault is before the fuse, no fault current flows through the branch so the fuse does not blow.
- For a fault at Point B, 800 amperes of fault current flow through both the overcurrent relay and the fuse. Again referring to Figure 8.5, we see that if the branch fuse were not there, the relay would operate in 4 seconds and kill the entire feeder. However, in this case, the fuse blows in 2 seconds to clear the fault and the overcurrent relay does not operate. As a result, only customers on the branch line will experience a power outage.

### ***Transmission Line Protection Systems***

Protection systems for transmission lines are usually more complex than distribution line protection systems because of the following features:

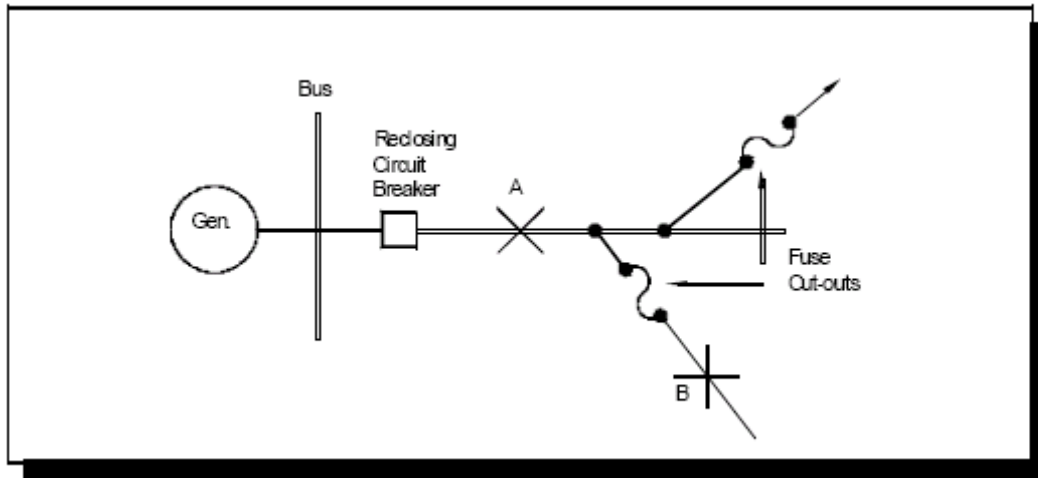
- As part of a power grid, transmission lines connect many generators. Therefore, current can flow in either direction on the line. Faults on adjacent circuits can result in fault current flow in unfaulted lines in either direction. Relaying is required to detect fault location and trip only the faulted line. (The overcurrent relays used for distribution line protection are unable to determine current direction.)
- The amount of current flow to a transmission line fault depends heavily on the overall condition of the power system (that is, what generators are on-line, what transmission lines are out of service, and so forth). Because the amount

of current flow is somewhat unpredictable, overcurrent relay settings would have to be very conservative. This could lead to unnecessary tripping.

- Fault current levels are usually high on transmission lines. If faults are not cleared rapidly, they can cause system instability, as well as extensive damage to equipment and possible personal hazards. **Module 9: Principles of Power System Operation**, discusses power system stability.

### ***Types of Transmission Line Protection***

Now we present information about five types of relay schemes typically used on transmission lines:

- (1) Directional Overcurrent Relaying
- (2) Distance Relaying
- (3) Pilot Schemes
- (4) Out-of-Step Relaying
- (5) Single Pole Relaying

#### **(1) Directional Overcurrent Relaying**

When there are sources at more than one line terminal, fault and load current can flow in either direction. Relays protecting the line are therefore subject to fault current flowing in both directions. If "nondirectional" overcurrent relays (that is, relays that do not determine the direction of current flow) are used, they have to be coordinated not only with relays at the remote end of the line, but also with the relays behind them.

**Figure 8.7: Coordinating Overcurrent Relays**

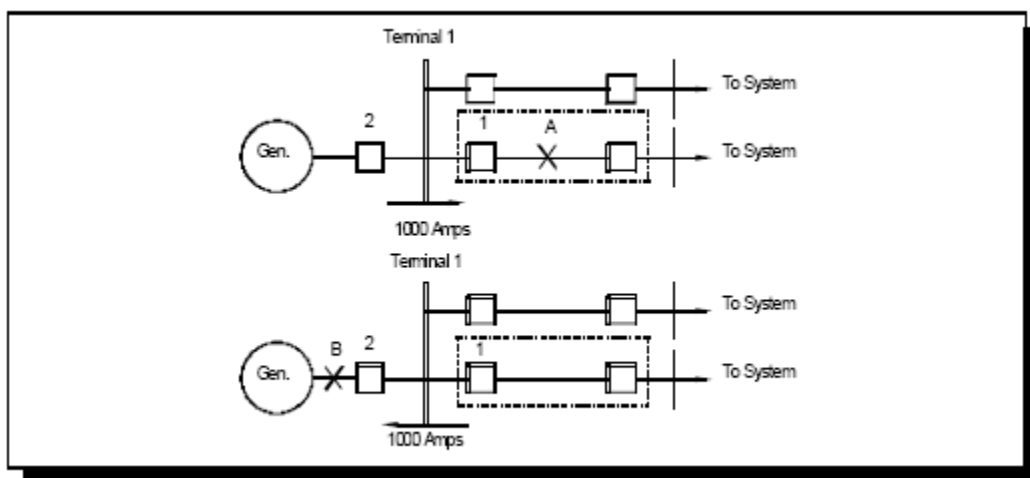

Figure 8.7 illustrates the following:

- If a fault occurs at Point A resulting in a fault current flow of 1,000 amperes through Terminal 1, relays at Terminal 1 are expected to operate rapidly to trip Circuit Breaker 1.
- A fault at Point B might also result in a current flow of 1,000 amperes through the relays at Terminal 1. However, in this case, the relays must be coordinated with the overcurrent relays on Circuit Breaker 2 since a fault at Point B does not require Circuit Breaker 1 to trip.

To avoid this complex coordination and the possibility of having to increase time delays before clearing the fault, utilities use directional overcurrent relays that operate only when fault current flows in the specified tripping direction.

Directional overcurrent relays require line voltage, as well as current, as inputs. Current direction is determined by comparing the phase angles of the current and voltage inputs. This type of relay will not function without an AC potential source.

- Current in one direction is relatively in phase with the voltage signal from the AC potential source.
- Current in opposite directions would be approximately 180° out of phase with the voltage signal.

## **(2) Distance Relaying**

Another type of relay scheme used for transmission line protection uses distance relays. This type of relay measures the distance from the relay to the location of the fault.

The "distance" in a distance relay refers to electrical distance or impedance. A distance relay monitors the voltage and current, compares the two, and computes  $Z$ . If this value is within the pre-set value of  $Z$  for the relay, the relay operates.

Recall from **Module 2: Fundamentals of Electricity** that impedance ( $Z$ ) is:

$$Z = \frac{V}{I}$$

We also know that the line's resistance and reactance values depend on the line length. So, an unfaulted line's  $Z$  is not the same as a faulted line's  $Z$ , since the fault essentially "cuts" the line at the place of the fault.

**Figure 8.8: Electrical Distance**

Figure 8.8 illustrates the following:

The impedance of the line from Station 1 to Station 2 is 15 ohms. If a fault occurs at Point A, the relay will measure impedance ( $Z$ ) of less than 15 ohms, indicating a fault. Then, the relay trips the line circuit breakers.

Distance relays may be

- directional – they detect faults in one direction only
- non-directional – they detect faults in both directions.

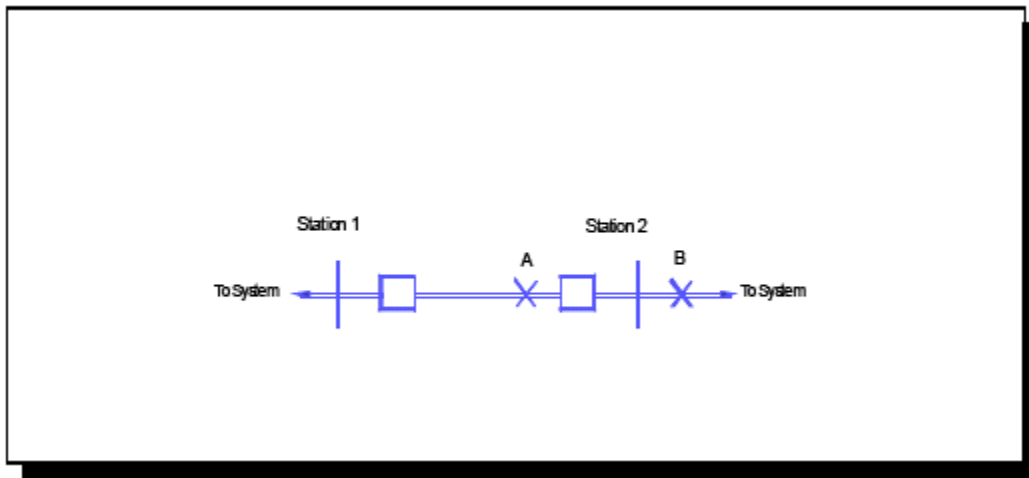
It would be ideal if a distance relay could be set to detect faults all the way to the end of the protected line by setting the trip impedance equal to the line impedance at the far end terminal. With this ideal situation, we could obtain high-speed tripping for all internal faults, regardless of their location on the protected line.

In practice, however, we cannot achieve this ideal situation. The impedance for faults just slightly beyond the end of the line is essentially the same as the impedance of the full line length. In addition, errors can be introduced by the relay and by the instrument transformers.

For example: If a fault occurs at Point B on Figure 8.8, the relay detects the same impedance as it detected for a fault at Point A.

Therefore, impedance settings that cover the entire line length would result in tripping for faults beyond the end of the protected line.

As a solution, the common practice is to provide multiple "zones" of distance relays for the protected line, as shown in Figure 8.9.

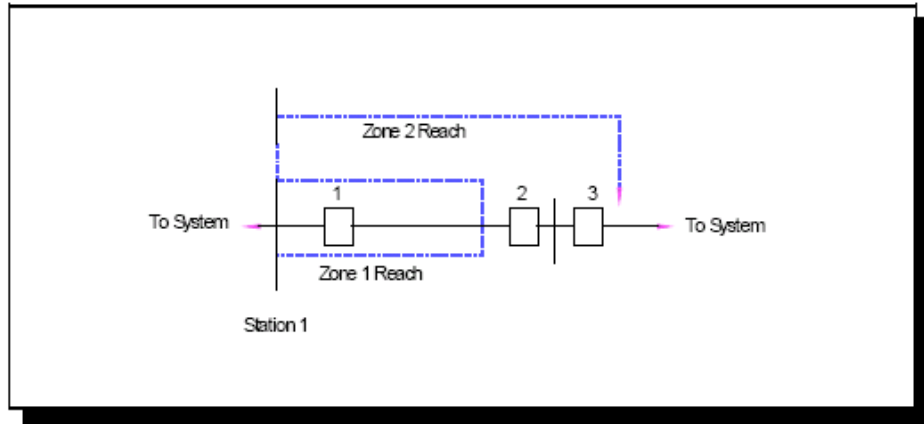
**Figure 8.9: Zones of Distance Relays****Definition: Reach**

The **reach** of a relay is the extent of protection it provides in terms of the impedance of the line. Reach is measured from the relay's location.

Figure 8.9 shows only the zones for circuit Breaker 1 for simplicity. Remember, Breaker 2 also has zones 1 and 2 "looking" toward Breaker 1.

Figure 8.9 shows the following:

- The Zone 1 distance relay is usually set to 80-90% of the line's impedance. High-speed tripping is provided for this portion of the line. The majority of faults occur within this zone.
- The Zone 2 distance relay is set to reach beyond the opposite end of the line (beyond Circuit Breaker 3). The Zone 2 relay includes a time delay before tripping. This allows the Zone 1 relay in the next line segment a chance to operate if the fault is beyond Circuit Breaker 3. Therefore, tripping is time delayed for faults in the last 10-20% of the line.

The major disadvantage of the distance relay is that the line faults in the last 10-20% of the line are always cleared from the far end after a time delay. This time delay and subsequent system shock may not be acceptable. The use of distance relays in a pilot scheme avoids this problem and provides high-speed tripping at all terminals for all faults.

### **(3) Pilot Schemes**

To provide high-speed tripping for end-zone faults (beyond Zone 1's reach) on a transmission line section, we must provide some form of communication channel between the line section terminals. A communication or "pilot" channel provides this capability. It allows the relays to compare fault conditions at the line terminals to determine whether the fault is internal or external to the protected zone.

**Figure 8.10: Pilot Schemes**

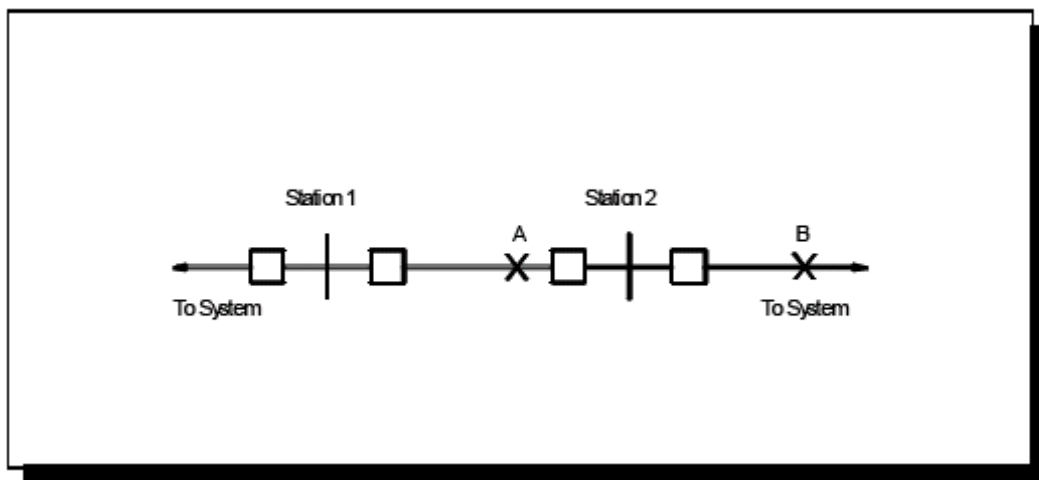

Figure 8.10 illustrates the following:

- If a fault occurs at Point A, relays at Station 1 and Station 2 advise each other that fault current is flowing into the line from both ends. This indicates a fault and requires tripping.
- If a fault occurs at Point B, external to the line, current flows toward the fault from Station 1 into the line. Relays at Station 1 are unable to determine if the fault is internal or external. They need help from the relays at Station 2. At Station 2, the current flows from the line to the fault. Therefore, Station 2 relays know the fault is external. Station 2 sends a signal to Station 1, via the pilot channel, indicating that the fault is external and tripping is not required.

There are many variations of pilot schemes, but all fall into one of the following four basic categories:

- Transfer Tripping
- Directional Comparison
- Phase Comparison
- Pilot-Wire

Most pilot protection schemes that we discuss require a communication channel that transmits an "on" or "off" signal to the opposite end of the line. This is almost always accomplished via some sort of "frequency shift keying" (FSK) communications subsystem, in which the transmitters are switched between two different frequencies to indicate the on and off conditions of the channel.

The most common media for the communication subsystem are:

- wire or optical-fiber lines, either leased from the telephone company or privately-owned, on which audio-frequency tones are applied
- microwave radio, which uses beamed radio signals, usually in the range of 2 to 12 GHz, over line-of-sight paths between terminals
- power line carrier, which uses low power radio-frequency energy transmitted via the power line itself.

Let's discuss each of the four categories of the pilot scheme, beginning with transfer tripping.

### **Pilot Scheme: *Transfer Tripping***

In a transfer tripping protection system, when relays at one end of the line detect a fault, the communication or "pilot" channel is turned on to signal the other end of the line that a fault has occurred. Many variations of this scheme exist. Two of the major ones are direct transfer tripping and permissive overreaching transfer tripping.

#### **Direct Transfer Tripping**

- Referring to Figure 8.9, we note that Zone 1 relays are set to detect faults over 80-90% of the line. In a direct transfer tripping scheme, when Zone 1 relays operate they trip the local circuit breaker and then turn on the pilot channel to send a "transfer trip" signal to the other end of the line.
- When the transfer trip signal is received at the far end of the line, the breaker at that end trips immediately. Since the portions of the line protected by relays at each end overlap, at least one of the relays detects any fault, including faults in the end-zones of the line.

#### **Permissive Overreaching Transfer Tripping**

This scheme uses Zone 2 directional distance relays that "overreach" the far end of the transmission line. These relays detect faults over the entire line section, as well as some faults that are external to the protected line.

**Figure 8.11: Permissive Overreaching Transfer Trip**

Figure 8.11 illustrates the following:

- For a fault at Point A, relays at Station 1 detect the fault and send a transfer tripping signal to Station 2 via the communication channel. Relays at Station 2 also detect the fault and send a transfer tripping signal to Station 1. Since the relays associated with both breakers detect the fault and receive a transfer tripping signal from the other station both breakers trip.
- For a fault at Point B (an external fault), relays at Station 1 detect the fault and send a transfer tripping signal to Station 2. However, relays at Station 2 do not detect this fault and therefore do not send a signal to Station 1 or permit the local breakers to trip. Although the Station 1 relays detect the fault, they do not receive a command to trip from Station 2, so neither breaker trips.

### **Pilot Scheme: *Directional Comparison***

Another variation of the pilot scheme is the directional comparison scheme. In this scenario, fault-detecting directional distance relays at each line terminal determine the direction of the fault current and compare their individual results over the pilot or communication channel.

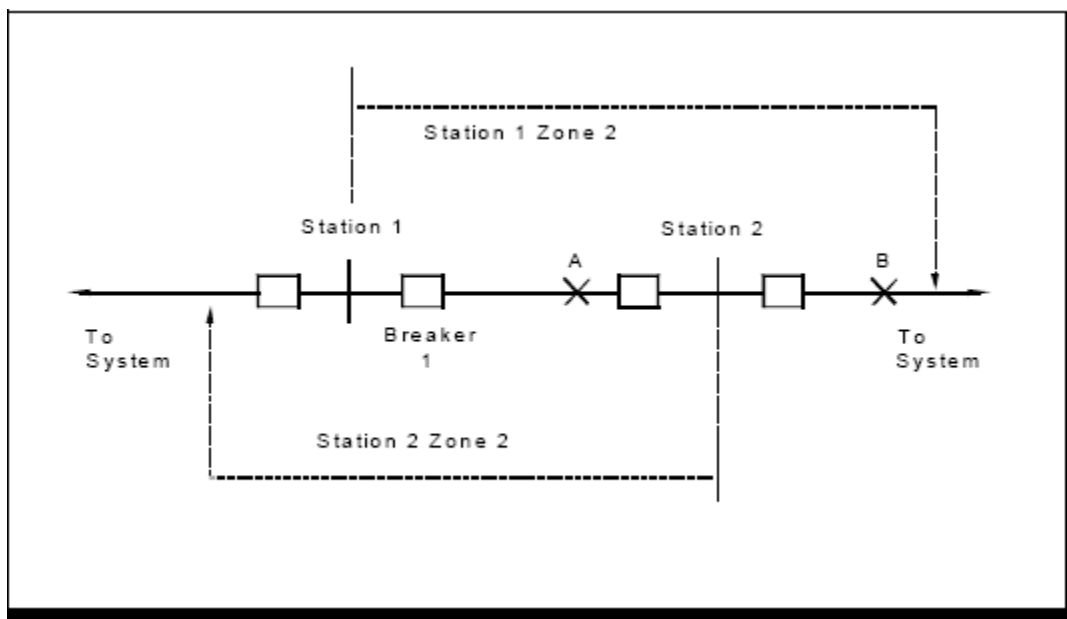
This protection scheme uses the pilot channel as a "blocking" system, rather than as a transfer tripping system. In a blocking system, a signal prevents one or more terminals from tripping on external faults. A communication signal is not required for internal faults; that is, tripping occurs in the absence of a blocking signal.

In a directional comparison protection system, each line terminal is equipped with directional distance relays, called trip relays. Trip relays look into the line and are set

to overreach the remote terminal; that is, they are set to operate for all internal faults. The trip relays trip their associated circuit breakers unless a blocking signal is received from the remote end of the line via the communication channel.

Each line terminal is also equipped with directional distance relays, called "blocking" or channel "start" relays. These look away from the protected line. The blocking channel start relays are set to see farther than the overreaching trip relays. If these blocking relays detect a fault, the pilot channel turns on and sends a signal to block tripping at the remote end of the line.

Let's look at an example.

**Figure 8.12: Directional Comparison**

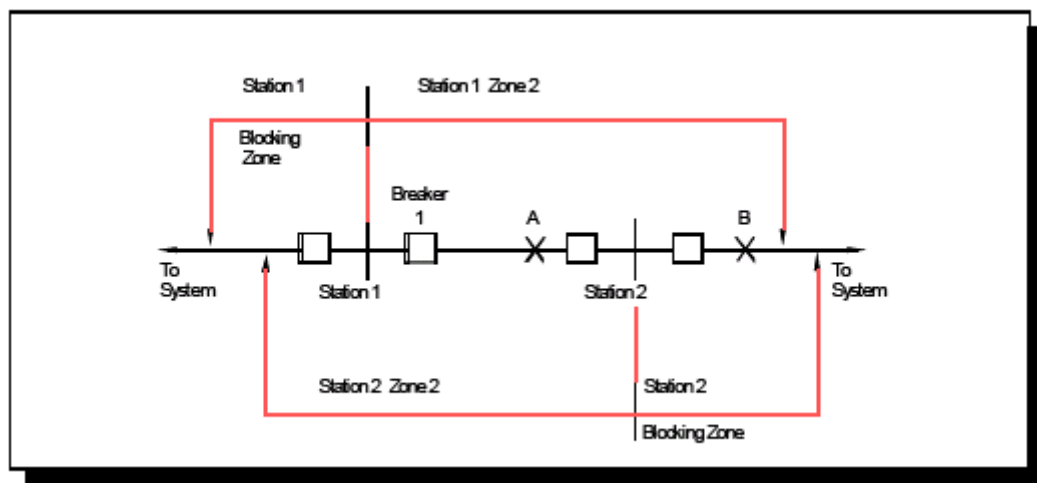

Figure 8.12 illustrates the following scenario:

- For a fault at Point B, the Station 2 blocking relays detect the fault and send a blocking signal to Station 1 so Breaker 1 does not trip even though Station 1 relays detect the fault.
- For a fault at Point A, Station 1 sends a trip signal to Station 2 and waits a few milliseconds for a blocking signal from Station 2. When it does not receive the blocking signal, relays at Station 1 trip Breaker 1.

A modification of the blocking system is the unblocking system. With this type of system, a signal must be transmitted continuously. For an internal fault, the signal is stopped.

### **Pilot Scheme: *Phase Comparison***

Phase comparison systems, another variation of the pilot scheme, use overcurrent fault detecting relays to compare the relative phase angles of the currents at the two terminals via the communication channel.

The phase comparison relays at each terminal produce a voltage signal that is representative of the current waveform at that terminal.

- In-phase currents at the terminals indicate an internal fault and the line trips. (The currents are in-phase since the currents at both terminals are flowing away from the bus and into the line.)
- 180° out-of-phase currents indicate an external fault or through-load current. The line does not trip. (The currents are out-of-phase since the current at one terminal is flowing into the line and away from the bus and the current at the other terminal is flowing into the bus and away from the line.)

**Pilot Scheme: *Pilot Wire***

Another commonly-used type of pilot protection system is the pilot wire relay system. This system compares the magnitude and phase angle of the current flowing at each end of the line to determine whether an internal fault exists.

The pilot wire relays at each terminal generate an analog voltage signal that is representative of both the magnitude and the phase angle of the current flowing at each end of the line. This signal is transmitted directly to the remote line terminal as an analog (60 Hz) signal for comparison purposes. That is, the signals are not converted to high frequency signals for communication purposes.

- Currents at the two ends that are approximately equal in magnitude and 180° out-of-phase indicate an external fault or through-load current.
- Currents at the two ends with magnitudes significantly different or relatively in phase indicate an internal fault and cause tripping.

Modern versions of the pilot wire relay systems are able to use fiber optic communication media and are functionally equivalent to the older style relay systems. However, the fiber optic systems require a sophisticated communication subsystem to transmit analog line information between terminals. We do not explore this subsystem further in this manual.

#### **(4) Out-of-Step Relaying**

Another type of transmission line protection system is the out-of-step protection system.

##### **Definition: Swings**

Protection systems must function properly during power system "swings". **Swings** are oscillations of generators with respect to other generators due to sudden changes of load, switching, or faults.

If swinging is severe enough to cause system instability, the role of the out-of-step protection system is to open pre-selected circuit breakers in order to split the power system into separate islands, so that generation and load in each island are reasonably well-balanced.

Swinging does not necessarily indicate system instability, because there are some swings for which the electric system is able to recover automatically. Therefore, the protection system must be able to recognize stable power swings from which the system can recover, and prevent circuit breakers from opening, which would increase the amount of swinging and possibly create an unrecoverable situation.

To function properly, out-of-step (OOS) protection systems must be able to:

- trip for non-recoverable stability conditions and true faults
- block tripping for recoverable swings

OOS protection systems accomplish these objectives by observing changes in the impedance of the line detected by the relay:

- If the impedance decreases suddenly to the relay's trip setting, a true fault has likely occurred. Therefore, tripping is required.
- If the impedance decreases gradually to the relay's trip setting, this most likely is due to swinging generators rather than a fault in the relay's protected zone. Therefore, the relay holds off tripping until it determines whether the system can recover from the swing.
- If the impedance returns to normal within a pre-determined time period, the relay assumes that the system has recovered and no tripping occurs.
- If the impedance stays low for a specified time period and then gradually moves above the trip setting, the system is probably unstable, so tripping occurs.

### **(5) Single Pole Relaying**

The last transmission protection system we discuss is single pole relaying.

#### **Definition: Single Pole Tripping**

Most transmission line faults are temporary single-phase-to-ground faults. They can be cleared by opening and reclosing only the faulted phase. This method is known as ***single pole tripping***. It leaves the other two phases intact and minimizes the shock to the power system.

To use this type of protection system, circuit breakers must have independent operating mechanisms for each phase. Most breakers do not have this capability.

The single pole protection system must accurately determine the faulted phase. While it sounds simple enough, you can't just pick the phase with the highest current flow. This is because current magnitude alone often is not a reliable indicator of which phase is faulted. More complicated methods, such as comparing the relative phase angles of the current on each phase, are required.

We must consider the following items when designing the single pole protection system:

- Opening one phase causes unbalanced current to flow in unfaulted portions of the power system. Ground relays must be set so as not to operate under this condition.
- Recall from ***Module 2: Fundamentals of Electricity***, that voltages can be induced in a conductor by a nearby energized line. Phases which remain energized may induce enough voltage to maintain arcing at the fault and impede the fault deionization process. Because of this secondary arc, the pole may re-trip when reclosing occurs.

The secondary arc must be extinguished before successful reclosing can occur. Several methods, of varying complexity and cost, are used, including:

- Delay reclosing from 50 to 60 cycles to allow time for the arc to extinguish.
- Take the arc to ground through a high-speed ground switch or through a line reactor.
- After tripping the faulted phase, delay for a short time and trip all three phases, then reclose all three phases quickly.

Many modern solid-state or microprocessor-based relays are equipped to provide single pole tripping.

Most transmission line faults are phase-to-ground. Therefore, ground protective relaying is of major significance. Most ground relays are overcurrent or distance. Under no-fault conditions there is negligible current flow in the CT neutral leg of the ground relay. The secondary current flow is confined to the phase relays. If there is an unbalance, such as a phase-to-ground fault, there is more secondary current on the faulted phase than can return to the other two phase relays.

Since the faulted phase current is higher than the current in the other two phases, the current returns to the CT by the path of least impedance. The return path of least impedance during a single phase-to-ground fault is through the ground relay.

The phase relays must be set high enough so that tripping does not occur on maximum line loading. When an "A" phase-to-ground fault occurs, secondary current rises in the phase "A" relay and ground relay.

Since the ground relay has a lower minimum trip value than any phase relay, it trips first.

Ground relays are set at much lower minimum trip settings than are phase relays. This is so they can trip on phase-to-ground faults sooner than phase relays.

This completes the line protection section. In addition to protecting transmission and distribution lines, we must protect the equipment within the substation. We discuss these protection systems in the next section.

## **Substation Equipment Protection Systems**

We can choose among a number of protection schemes within the substation to protect substation equipment. The schemes include:

- Shunt Equipment Protection
- Bus Protection
- Transformer Protection
- Circuit Breaker Failure Protection
- Underfrequency Load Shedding

### ***Shunt Equipment Protection***

Shunt equipment, such as a capacitor bank, is usually protected using:

- Time overcurrent or differential relays which open circuit breakers to de-energize this equipment during a fault.

Or

- Fuses that blow to de-energize the device when high current flow occurs.

## ***Bus Protection***

Substation buses usually have one or more incoming lines that are sources of fault current, and multiple outgoing lines, that may or may not be sources of fault current.

**Figure 8.13: Bus Protection**

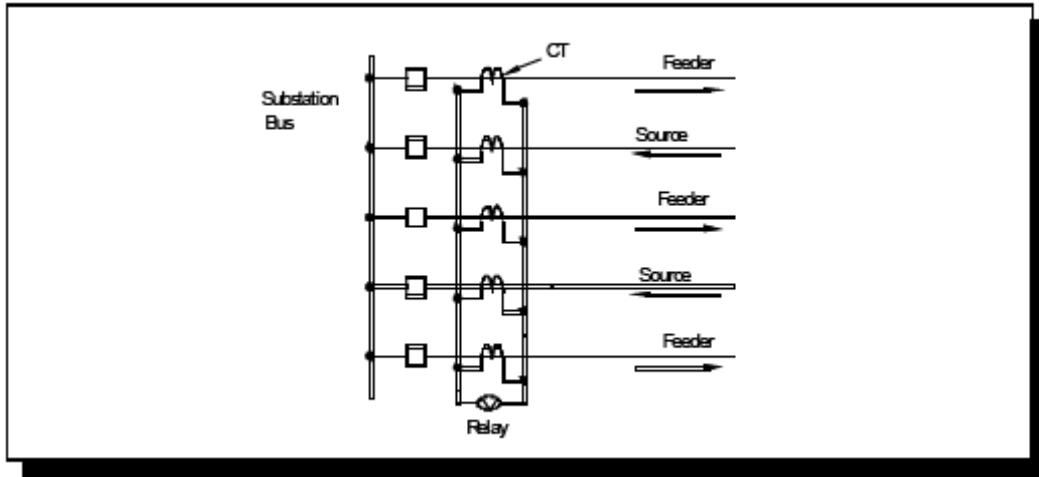

Differential protection is the most sensitive and reliable method for protecting substation buses, because:

- all currents entering and leaving the bus are added
- the difference between the incoming and outgoing currents is the input to a sensitive overcurrent relay.

Under normal circumstances, all current that enters the bus on an incoming line must leave the bus on an outgoing line. (Current cannot "pile up" on the bus.) Therefore, the difference current sent to the relay is approximately zero. In actual practice, a small difference current is always present due to slight dissimilarities in the current transformer characteristics and performance.

When a bus fault occurs, the incoming and outgoing line currents will no longer add up to zero because much of the incoming current flows to the fault. The resulting difference current causes the overcurrent unit of the differential relay to operate, tripping all bus circuit breakers for lines that are sources of fault current.

## ***Transformer Protection***

The most common forms of protection systems for substation transformers are overcurrent, differential and sudden pressure detection.

Transformer overcurrent and differential protection systems are similar in concept to the previously discussed applications, in that:

- Transformer overcurrent relays detect abnormally high current flow to the transformer.
- Transformer differential relays subtract the current leaving the transformer from the current entering the transformer, and then use the difference current to determine if an internal fault exists.

However, both of these schemes are complicated by magnetizing inrush current flow to the transformer. When a transformer is first energized, a transient magnetizing or exciting current may flow. Inrush current can reach peak values of up to 30 times the full-load value, which is more than enough to cause an overcurrent relay to operate. And, because inrush current flows into the transformer and not out the other side, differential relays may interpret this current as an internal fault.

### **Definition: Harmonics**

To prevent overcurrent and differential relays from operating on inrush current, we must use special relays with reduced sensitivity to inrush currents. Typically, such relays filter out the harmonic content of the current before deciding whether a fault exists. **Harmonics** are electric currents that alternate at a frequency other than 60 Hz. In some cases, the harmonic portion of the current restrains the operation of the relay until the inrush currents decay (die out) to an insignificantly small value.

Transformer sudden pressure relays operate if the gas pressure in the transformer abruptly rises to a certain level. Sudden pressure increases indicate a fault. Transformer gas usually results when "arcing" from internal faults breaks down the transformer's insulating oil.

### ***Circuit Breaker Failure Protection***

Problems can occur which prevent a circuit breaker from operating when called upon by a protection system. Wiring and other control components can be faulty, or mechanical problems in the breaker itself may prevent the breaker from opening to clear a fault.

Faults that are not cleared by the primary protection system and associated circuit breakers almost always will eventually be cleared by protection systems in adjacent protection zones. But the delay in clearing the fault can be intolerable on high-voltage facilities.

Circuit breakers at important high-voltage facilities are frequently equipped with circuit-breaker-failure detection circuitry. When the protection system sends a trip signal to the circuit breaker, it also starts a timer. The timer is normally set to a little

more than the normal breaker opening time. If the timer expires and the breaker has not yet opened, the protection system assumes that the circuit breaker has failed. Circuit breakers are then tripped for all adjacent protection zones that can supply current to the original fault.

### ***Under-frequency Load Shedding***

In a stable power system, the generator control systems usually maintain system frequency very close to 60 Hz. Sudden or large changes in generating capacity due to the loss of a large generator or tie-line can cause a severe generation/load imbalance, resulting in a frequency decline.

It is common practice to install a protection system that measures frequency. When under-frequency conditions occur, the protection system trips predetermined loads in blocks of various amounts to restore the generation/load balance.

This completes the section on substation equipment protection systems. Next, we examine protection systems for generators.

## **Generator Protection Systems**

Although the frequency of generator faults is low, the potential for severe damage and consequently long outages is high. Therefore, some of the most complex and sensitive protection systems are used for the generators. Some of the most common methods of detecting faults in generators are:

- Winding Differential Protection
- Ground Fault Protection
- Detection of Unbalanced Faults
- Overload Protection
- Loss-of-Excitation Protection
- Generator Motoring Protection
- Generator Protection at Reduced Frequencies

### ***Winding Differential Protection***

With the winding differential protection scheme, the currents in each phase on each side of the machine are compared in a differential circuit. Any significant difference in current is interpreted as some form of fault and the relay operates.

## ***Ground Fault Protection System***

It is difficult to detect small generator ground faults before they become big ones. Current-type relays are generally inadequate for detecting generator ground faults.

It is more common for the protection system to measure the voltage of the generator neutral with respect to ground. A sensitive over-voltage relay is connected across the resistor of the generator neutral. A ground fault anywhere in the generator's protection zone causes a voltage to appear across the neutral resistor, operating the relay to trip the generator.

## ***Detection of Unbalanced Faults***

We know from ***Module 2: Fundamentals of Electricity***, that electric power systems are three-phase and normally balanced on all phases.

Sometimes abnormal conditions exist on parts of the system causing unbalanced conditions. These include:

- single phase-to-ground faults
- line-to-line faults
- unbalanced voltages
- open circuits

To protect the generator from damage caused by unbalanced faults, a relay system called negative phase sequence (unbalance) relaying is used to sense the condition and trip the machine.

## ***Overload Protection***

Most large generators are equipped with resistance temperature detectors (RTDs) that detect overheating due to overload. Typically, the outputs from this RTD drive a warning light to inform the plant operator of the potential overload conditions. The RTD may also be used to provide a trip signal.

## ***Loss-of-Excitation Protection***

Recall from ***Module 4: Principles of Power Generation***, that the function of the generator excitation system is to provide direct current for the generator rotor windings (field windings). The generator excitation system:

- maintains generator voltage
- controls reactive power flow
- assists in maintaining power system stability

Excitation can be lost due to tripping of the field breaker, poor brush contact in the exciter, short circuits in the field windings, and other conditions. When this occurs, reactive power flows from the power system into the generator. The generator may operate as an "induction" generator, supplying the same power output at reduced frequency.

The machine output oscillates as the unit controls attempt to stay in synchronization with the rest of the power system. If not detected early, this may cause system instability and damage to the generating unit.

The loss-of-excitation protection system responds to excessive voltage decays and swings in impedance that usually accompany this condition.

The protection system may produce a loss-of-field warning alarm if conditions are not yet severe. Then the operator may take corrective action. If conditions deteriorate, the protection system trips the unit.

### ***Generator Motoring Protection***

If an undetected prime mover problem occurs (e.g., low steam or water flow), the input to the turbine may be too low to meet all the losses in the generator. The turbine compensates for this deficiency by absorbing real power from the power system. Now, the machine is performing in a manner similar to a synchronous motor. A protection system that detects reverse power flow (into the machine) identifies generator motoring.

Generator motoring protection is designed to protect the prime mover rather than the generator itself, since generator motoring does not harm the generator, provided it is running at synchronous speed.

However, steam turbines experience blade overheating when operating on low steam flow, hydroelectric units experience blade cavitation, and combustion turbines may suffer blade overheating. Protective relays monitor temperatures as well as water and fuel flows. They can sound alarms or trip the machine.

### ***Generator Protection at Reduced Frequencies***

During steam unit start-up, it is common to "pre-heat" the turbine by gradually bringing up turbine speed to its rated value.

During this period, the generator protection systems must be operational, because the generator is able to deliver fault current and create over-voltages. However, many of the commonly-used voltage and current relays designed for 60 Hz operation are less sensitive at low frequencies. Current transformer performance also may deteriorate badly.

Supplementary protective relays with reduced sensitivity to frequency changes provide reliable protection under these conditions. Utilities use overvoltage relays of this type, typically called "Volts per Hertz" relays, to avoid overexciting the unit or station service transformer.

**Figure 8.14: Generator Frequency Trip Settings**

<b><u>Under-frequency Limit (Hz)</u></b>	<b><u>Over-frequency Limit (Hz)</u></b>	<b><u>Time Delay before tripping</u></b>
<b>60.0-59.5</b>	<b>60.0-60.5</b>	<b>NA (normal)</b>
<b>59.4-58.5</b>	<b>60.6-61.5</b>	<b>3 minutes</b>
<b>58.4-57.9</b>	<b>61.6-61.7</b>	<b>30 seconds</b>
<b>57.8-57.4</b>		<b>7.5 seconds</b>
<b>57.3-56.9</b>		<b>45 cycles</b>
<b>56.8-56.5</b>		<b>7.2 cycles</b>
<b>&lt;56.4</b>	<b>&gt;61.7</b>	<b>Instant. trip</b>

This completes the section on generator protection systems. The last relay application to be discussed is a Remedial Action Scheme (RAS) also known as a Special Protection System (SPS).

## Remedial Action Schemes

Remedial action schemes, also called special protection systems, initiate actions to prevent power system instability and equipment overloads if critical network elements are lost.

Remedial action scheme requirements are unique for each power system. These protection schemes typically result from engineering studies that identify potential system "weak" spots if certain contingencies occur. A contingency is the loss of one or more power system elements, such as a transmission line, transformer, or generator.

The types of functions performed by remedial action schemes include:

- tripping selected generating units
- inserting capacitors or dynamic braking resistors
- shedding load
- tripping selected transmission lines

These functions are performed to prevent overloading lines and losing critical facilities.

Remedial action schemes expand the use of the transmission system when utilities cannot build or justify additional facilities. Utilities can obtain higher power transfers and more economical generation by using remedial action schemes to automatically readjust system operations following a contingency.

**Conclusion:** This concludes the module on system protection. The purpose of this module is to discuss system protection. We discuss the purpose of protection systems and provide some types of relay devices and their applications. Relay use varies from utility to utility. You should review in detail the types of relays your utility employs.

**Module 8: System Protection  
Question Set**

## **Module 8 System Protection**

### **Question Set**

**8.1** Identify the purpose of a protection system.

**8.2** Answer the following questions about faults:

**(a)** Define fault.

**(b)** What are some common causes of faults?

**(c)** Describe the difference between an internal fault and an external fault.

**8.3** Provide the following information about the components of a protection system:

**(a)** List the three components of a protection system.

**(b)** Describe each of the three components of a protection system.

**8.4** Define a protection zone.

**8.5** List three causes of protection system failure.

**8.6** Why must the overcurrent protection system be coordinated with the branch line fuses for a distribution feeder?

**8.7** List three relay schemes used on transmission line protection systems.

- 8.8** Match the relay type in Column 1 with the relay operating principle in Column 2.

Column 1	Column 2
____ Transfer Trip	A. Each line terminal is equipped with trip relays and blocking relays. The trip relays trip their associated circuit breaker unless a blocking signal is received from the remote end of the line via the communication channel.
____ Distance	B. When relays at one end of the line detect a fault, the communication or pilot channel is turned on to signal the other end of the line that fault has occurred.
____ Phase Comparison	C. Overcurrent fault detecting relays compare the relative phase angle of the current at the two terminals. In phase currents indicate an internal fault and the line is tripped.
____ Directional Comparison	D. Relays that measure the distance from the relay to the location of the fault. The relay monitors the voltage and current, compares the two, and computes the impedance.

- 8.9** List two media used for the communication subsystem for pilot schemes.

- 8.10** Describe single pole tripping.

**8.11** Provide the following information about differential protection:

**(a)** Describe differential protection.

**(b)** Identify two pieces of equipment protected by differential protection systems.

**8.12** Fill in the blanks:

1. \_\_\_\_\_ relays detect abnormally high current flow to the transformer.
2. \_\_\_\_\_ relays subtract the current, leaving the transformer from the current entering the transformer and then use the difference current to determine if an internal fault exists.
3. Both of these schemes are complicated by \_\_\_\_\_ current flow to the transformer. This current is a result of the transformer being energized and a transient magnetizing or exciting current flowing.

**8.13** Describe remedial action schemes and state one type of function performed by a remedial action scheme.



**Module 9:  
Principles of Power System Operation**

This page intentionally left blank.

## **Module 9: Principles of Power System Operation**

### **Table of Contents**

<b>Principles of Power System Operation .....</b>	<b>9-5</b>
<b>Section 9.1: Energy Balance .....</b>	<b>9-5</b>
<b>Section 9.2: Interconnected Operations .....</b>	<b>9-8</b>
<b>Section 9.3: Automatic Generation Control (AGC) .....</b>	<b>9-11</b>
<b>Section 9.4: Operating Limits .....</b>	<b>9-13</b>
Thermal Limits.....	9-14
Conductor Ratings .....	9-14
Summer and Winter Ratings.....	9-15
Normal, Peak, and Emergency Ratings .....	9-15
Transformer Ratings .....	9-15
Voltage Limits.....	9-16
<b>Section 9.5: Power System Stability .....</b>	<b>9-16</b>
Stability Problems .....	9-17
Stability Conditions.....	9-21
Subsynchronous Resonance .....	9-22
<b>Section 9.6: Computer System Functions .....</b>	<b>9-22</b>
Supervisory Control and Data Acquisition .....	9-23
Automatic Generation Control .....	9-23
Economic Dispatch.....	9-24
Unit Commitment .....	9-24
Interchange Transaction Scheduling .....	9-25
Hydroelectric Coordination .....	9-25
Hydrothermal Coordination .....	9-26
Power System Analysis.....	9-26
Information Storage and Retrieval.....	9-27
<b>Module 9: Principles of Power System Operation Question Set .....</b>	<b>9-29</b>

**Module 9:  
Principles of Power System Operation**

**Table of Figures**

Figure 9.1: Energy Balance .....9-6  
Figure 9.2: Interconnected System .....9-10  
Figure 9.3: Power Transfer.....9-19

## Principles of Power System Operation

### Module Overview

The **Principles of Power System Operation** module presents the following topics:

- Energy Balance
- Interconnected Operations
- Automatic Generation Control
- Operating Limits
- Power System Stability
- Computer System Functions

In previous modules we have discussed many power system elements; from generating stations to system protection. As a system operator, you are responsible for operating and controlling the power system so the power is generated and delivered to customers and other utilities as reliably and economically as possible. In this module, we apply some of the concepts developed in other modules to the operation of the power system.

Let's begin by discussing why it is necessary to match the power supply to the customer demand.

### Section 9.1: Energy Balance

We are now familiar with the various devices that produce and consume electric power. Generators supply the power and customers use the power.

Like other businesses, utilities supply a product to their customers. Utilities are different in that their product, power, cannot be produced in advance and stored. So at all times, utilities must supply enough power to meet the needs of their customers.

An electric power system can be thought of as an energy balance system. The generation must be equal to the customer load.

**Figure 9.1: Energy Balance**

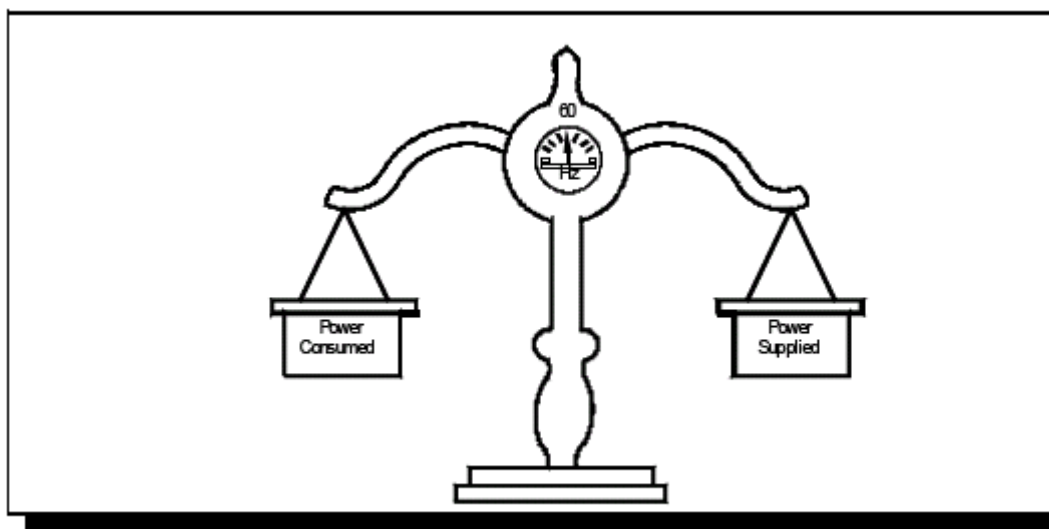

Figure 9.1 illustrates the following:

- Power Supplied = Power Generated + Power Imported - Power Exported
- Power Consumed = Customer Demand + System Losses
- If the system is in perfect balance, the frequency is equal to 60 Hz.
- If there is a power imbalance, frequency excursions occur:
  - When the system is over-generating (supply > demand), the frequency increases above 60 Hz.
  - When the system is under-generating (supply < demand), the frequency decreases below 60 Hz.
  - The amount of frequency deviation is determined by the amount of generation and load imbalance. The greater the imbalance, the greater the frequency deviation.

Severe frequency excursions (below 59.5 or above 60.5) can damage utility and customer equipment. Frequency excursions can also lead to time error accumulation.

- Electric clocks run faster when the frequency is high (over-generation).
- Electric clocks run slower when the frequency is low (under-generation).

So what can be done to maintain the power balance?

Control systems on the generators regulate the power output to meet the load. But the range of control is limited. You, the system operator, have the ultimate

responsibility to balance the power system. The remainder of this module provides some insight on how to accomplish this.

We know that for the electric power system to operate properly, the amount of electricity generated must exactly match the amount of power used by the customers, plus that consumed in losses.

- If load exceeds generation, the power system generators momentarily slow down, causing a reduction in the system frequency. In this case, the generating unit's control systems must increase the mechanical power input to the turbine (steam, gas, or water flow) to the point of stabilizing the system at a lower frequency. Automatic Generation Control (AGC) provides supplemental control to move the system back to 60 Hz. We discuss AGC in more detail later in this module.
- If generation exceeds load, generators momentarily speed up, increasing the system frequency. The mechanical power input must then be reduced to restore the desired frequency.

#### **Definition: Frequency Response Characteristic (FRC)**

Each generator has a ***frequency response characteristic***. A frequency response characteristic is the amount of generation response to a frequency change, usually expressed in MW/0.1 Hz.

Load changes fall into two basic categories, regulating units and spinning reserve.

#### **Definition: Regulating Units**

- Relatively small load changes – These increases and decreases occur continuously on the power system as customer demand routinely fluctuates. To maintain a balance between load and generation, the loading on fast-responding generators, called ***regulating units***, requires small adjustments. When available, hydroelectric units perform this task.
- Daily load cycles – These changes are generally larger and more predictable than regulating load swings. Utilities employ units that can be placed in service, loaded, and unloaded quickly to balance load changes associated with daily cycles. Peaking units, such as combustion gas turbines, generally handle this function.

The balance between load and generation may suddenly be disrupted if a key generating unit trips off-line. To prevent such an occurrence from dragging system frequency to an unacceptably low level, we require a rapid increase in the loading of on-line generating units to compensate for the lost generator.

**Definition: Spinning Reserve**

It is normal practice for power companies to load some generating units to something less than maximum load, so that the remaining spare or reserve capability may be used to respond to the loss of a generator. This spare capability is called spinning reserve. **Spinning reserve** is reserve capability that can be converted to energy within ten minutes. It is provided by equipment electrically synchronized to the system and responding automatically to frequency changes. Within various power pools, there are methods of sharing reserve capabilities.

<h2>Section 9.2: Interconnected Operations</h2>
---

**Definition: Interconnected System**

Utilities usually do not operate as electrical islands. Rather, they interconnect their power transmission systems to allow power to flow between Balancing Authorities. An **interconnected system** consists of two or more individual power systems normally operating with connecting tie lines.

There are many benefits to interconnected systems, including:

- **Reliability:** Interconnected utilities can rely on the transmission tie line capacity to assist in meeting the changing load demands. If one system suffers the sudden loss of a generating unit, generating units throughout the interconnection experience a frequency change and can help in stabilizing frequency.
- **Economy:** Interconnected systems allow utilities to buy and sell power with neighboring systems whose operating costs make such transactions profitable. Neighboring utilities commonly establish contracts with each other that allow each company to buy or sell specified amounts of power at certain times or under predetermined conditions. The contract may also specify the transmission path to be used for these transactions.

With the advent of deregulation, the Federal Energy Regulatory Commission (FERC) has set forth rules and regulations pertaining to the purchase and sales of available transmission capacity and energy sales. The Open Access Same Time Information System (OASIS) was developed to ensure that a fair and equitable method is used for the sales and purchase of transmission facilities to transmit energy between parties. There must be proof of transmission purchase, an OASIS reservation number, and electronic tag associated for all interchange transactions between Balancing Authorities.

**Definition: Interchange Schedule**

At the agreed-upon time, the seller increases generation and the buyer decreases generation to cause power to flow from the seller to the buyer. This agreement is called an *interchange schedule*.

**Definition: Loop Flow**

Power does not only flow over the desired path. Rather, it flows over all available paths in inverse proportion to the relative impedance of those paths. This leads to the phenomenon known as *loop flow, parallel path flow, or inadvertent flow*. An interchange schedule between two utilities can increase the transmission line loading of another utility not otherwise involved in the transaction, leading to the following adverse effects:

- Decreasing margins within stability limits
- Increasing transmission line losses
- Needing to adjust interchange schedules

Adjusting generation can control loop flow; however, this may not always be the most economical solution. Many utilities use phase shifting transformers to control loop flow. Controlling loop flows requires cooperation from all interconnected utilities.

You may recall from *Module 4: Principles of Power Generation*, that prior to closing the generator circuit breaker; the generator voltage must be synchronized to the power system voltage. A similar requirement must be observed prior to synchronizing power systems. When synchronizing two power systems, however, the inertias are significantly greater and more care must be taken to ensure proper conditions exist before closing the circuit breaker. If the frequency and phase angle are not carefully matched, extremely high currents can result that cause damage to equipment.

One problem that requires the system operator's attention is the closing of a parallel tie on a long transmission loop. If the system operator closes a loop that has a large phase angle across the open circuit breaker, the angle immediately reduces to zero and large amounts of power instantly begin to flow across the breaker. Nearby generators and transformers may be damaged.

One method of reducing the phase angle across the circuit breaker is to adjust generation levels of nearby generating units. These adjustments also affect loop flow. Another method of reducing the phase angle is to sectionalize the loop and make the final closure at a location where the angle across the open point is at a minimum.

Interconnecting power systems can create problems with determining how to allocate generation to meet load.

**Figure 9.2: Interconnected System**

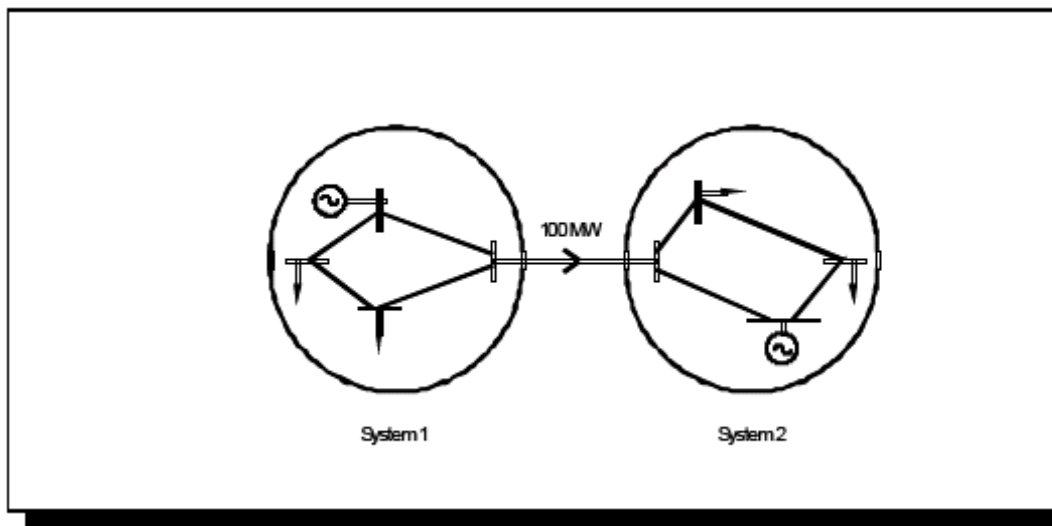

Refer to Figure 9.2 for the following example:

- Assume System 1 and System 2 have equal frequency response characteristics (each system provides the same response to load or generation changes). System 1 has a contract to supply 100 MW to System 2 and a schedule has been established for that amount.
- During the contract, System 2 experiences a sudden load increase of 60 MW. The frequency on both systems declines slightly.
- Since System 1 and System 2 have equal frequency response characteristics, both System 1 and System 2 respond with 30 MW generation increases. This means the tie line flow from System 1 to System 2 increases from 100 MW to 130 MW.
- System 1 contracted to provide 100 MW, not 130 MW.

A control scheme is needed that recognizes that the 60 MW load increase occurred in System 2 and that System 2 should increase its generation by an additional 30 MW to restore frequency. The scheme that provides the needed capability is called Automatic Generation Control (AGC).

## Section 9.3: Automatic Generation Control (AGC)

### Definition: Automatic Generation Control (AGC)

**Automatic Generation Control (AGC)** automatically adjusts generation from a central location, using some form of computer control, to maintain the desired load/generation balance. It does so in response to an error signal called **Area Control Error**. The computer implementation for AGC is discussed in Section 9.6: Computer System Functions.

### Definition: Area Control Error (ACE)

**Area Control Error (ACE)** is the instantaneous difference between actual and desired conditions of the control parameters being used. These parameters differ for the different **control modes** used.

### Definition: Tie Line Bias Control

**Tie line bias control** is the normal mode used. It uses both frequency and tie-line power flow to calculate ACE. A more descriptive term for this control mode is *constant net interchange with frequency bias*. It recognizes the following:

- If frequency decreases and the power leaving the system increases (or power entering the system decreases), then the need for power is outside the Balancing Authority.
- If frequency decreases and the power leaving the system decreases (or power entering the system increases), then the need for power is inside the Balancing Authority.

### Definition: Flat Frequency Control

**Flat frequency control** responds only to frequency changes, as described in the example of Figure 9.2. It does not respond to power flow changes on tie lines. This mode is used only on an isolated system, since it could lead to overloading tie lines while correcting frequency in an interconnected system.

### Definition: Flat Tie Line Control

**Flat tie line control** responds only to changes in power flow on tie lines. It does not respond to changes in frequency. To prevent large frequency deviations, it is used only for brief periods when a frequency measurement is not available.

### **Definition: Balancing Authority**

**Balancing Authority:** NERC Defines a Balancing Authority as *The responsible entity that integrates resource plans ahead of time, maintains load-interchange-generation balance within a Balancing Authority Area, and supports Interconnection frequency in real time.*

A Balancing Authority is also a part of an interconnected power system that regulates its generation to maintain its interchange schedule with other systems and to assist the interconnected system in controlling frequency.

The Balancing Authority boundaries are the metered tie points with other Balancing Authorities.

There may be one or more utilities within a Balancing Authority. All utilities must either operate a Balancing Authority or make arrangements to be included in the Balancing Authority of another utility. Utilities may exchange power with other utilities within their Balancing Authority or with neighboring Balancing Authorities.

Tie line bias control, as practiced in WECC, includes Automatic Time Error Correction. ACE is calculated as follows:

- ACE = (Net Interchange Actual - Net Interchange Scheduled) X -10 times a Frequency Bias Setting x (Frequency Actual – Frequency Scheduled) - Meter Error ( the WECC ATEC is included in the ACE equation)

$$ACE = (NI_A - NI_S) \times -10(\beta)(F_A - F_S) - I_{ME}$$

- The frequency bias setting is a constant unique to the Balancing Authority. It is based on the area's frequency response characteristic. The time error bias setting is a fraction of the frequency bias, currently 30 percent.
- A positive ACE indicates the need to lower generation to correct for over-generation.
- A negative ACE indicates the need to raise generation to correct for under-generation.

### **Definitions: Time Error and Accumulated Frequency Error**

Sustained frequency deviations lead to accumulating time error. A clock that ticks off one second for every 60 cycles of power runs slow if frequency is less than 60 Hz or fast if frequency is above 60 Hz. Another term for time error is *accumulated frequency error* (AFE). If the time error cannot be maintained at a small value By utilizing automatic time error correction, Balancing Authorities coordinate with one another to adjust the system frequency to correct the time error. The frequency is adjusted to 59.98 Hz to correct for fast time error or to 60.02 Hz to correct for slow time error. Utilities use manual time error correction only if the time error grows to  $\pm$

five (5) seconds. The manual time error correction will be lifted when the time error correction returns to less than  $\pm 0.5$  seconds.

### **Definitions: Net Scheduled Interchange and Net Actual Interchange**

Ideally, all power flowing between systems is scheduled. The ***net scheduled interchange*** is the sum of all the scheduled interchange transactions at any time. The ***net actual interchange*** is the sum of the actual power flow on the Balancing Authority's tie lines at any time. The mathematical sign convention is negative (-) for flows and schedules into the area and positive (+) for flows and schedules out of the area.

### **Definition: Inadvertent Interchange**

***Inadvertent interchange (inadvertent)*** is the difference between net actual interchange and net scheduled interchange. It is calculated each hour and accumulated in an inadvertent account for later payback to the interconnected systems. Inadvertent shows the imbalance between power commitments and power supplied by the Balancing Authority.

The primary causes of inadvertent are:

- AGC lag, which is the inability of generation to exactly match load changes as quickly as they occur
- The bias response to frequency and time deviations
- Metering errors
- Scheduling errors (giving the computer a wrong schedule)

## **Section 9.4: Operating Limits**

Electric current flowing from the generators to the loads follows all available paths. Most current flows over paths that offer the least impedance through conductors, transformers, and other power system components. On well-designed power systems, natural load flows are such that no lines are overloaded under normal circumstances. In some cases, phase-shifting transformers may be required to alter the natural current flows on the transmission system.

- If a transmission line is opened for any reason, such as a fault, current flows almost instantaneously redistribute over the remaining transmission system.
- Power systems are generally designed to handle contingencies, such as a line tripping, without overloading any facility. However, this is not always

possible, particularly when other lines are already out of service. Therefore, system operators may be required to implement emergency switching actions or arm special remedial action schemes during certain contingencies to prevent equipment loadings from exceeding emergency ratings.

To effectively control the power system, the voltage levels, frequency, transmission line flows, and equipment loading must be within limits. We discuss thermal limits and voltage limits in this section.

## Thermal Limits

We know from previous modules that any current-carrying device that has resistance experiences heating due to the current flow. Excessive heat buildup can result in insulation breakdown or other damage to the equipment.

To avoid excessive heating, utilities assign thermal limits or ratings to devices.

These limits should not be exceeded.

- The ratings are based on the amount of heat the device can carry and dissipate. Ratings are expressed in amps, MW, or MVA.
- Ratings vary with season and the amount of time the device is exposed to the high current.

Each energized device (a circuit breaker, the bus work, transformer, conductor, etc.) has an individual rating. When multiple devices in series (e.g., a transmission line and a series capacitor) have different thermal limits, the most restrictive rating applies to the combination of facilities.

Conductor and transformer ratings are typically the most restrictive factors.

Let's look at the thermal ratings of a conductor and a transformer.

### ***Conductor Ratings***

Transmission line conductors are rated to minimize the following:

#### **Definition: Annealing**

- the reduction of conductor strength due to annealing over the life of the conductor (***annealing*** is the process of heating and cooling the conductor)
- the increase in conductor sag due to thermal expansion at high temperatures (minimum conductor-to-ground clearances must be maintained at all times)

The conductor's temperature determines the annealing and sag. The principal factors that affect conductor temperature are:

- heat buildup due to conductor  $I^2R$  losses over time
- heat loss due to wind velocity and, to a lesser extent, ambient air temperature

There are usually several ratings, tailored to local loading and weather conditions that apply to a given line.

### ***Summer and Winter Ratings***

Winter ratings are typically higher because of the higher wind velocities and lower ambient temperatures.

### ***Normal, Peak, and Emergency Ratings***

#### **Definition: Normal Rating**

***Normal rating*** is the maximum current that can flow on a continuous basis.

#### **Definition: Peak Rating**

***Peak rating*** is the current that can be tolerated for a limited time period, usually four hours. In general, the peak rating is higher than the normal rating.

#### **Definition: Emergency Rating**

***Emergency rating*** is the highest rating of the line. This rating is the maximum current that is permissible for a short period of time, usually one hour or less. Utilities may operate at the emergency rating during abnormal power system conditions.

Now, let's examine transformer ratings.

### ***Transformer Ratings***

A transformer's rating is based on the amount of heating that the transformer's insulation can tolerate. High temperatures decrease the mechanical strength and increase the brittleness of the insulation, making transformer failure more likely.

You can imagine that the transformer's insulation has a fixed maximum lifetime. Whenever the transformer is heavily loaded, the insulation is heated, reducing the remaining life.

- The remaining lifetime can be calculated from the transformer load, using constants derived during tests performed at the time the transformer was manufactured.
- Utilities typically decide how long they expect the transformer to last, and then select ratings that will not cause the transformer to deteriorate faster than expected.

Transformer ratings are typically based on the anticipated daily load cycle. Since a transformer's load at off-peak hours of the day is well below its rating, the transformer load may exceed its rating for short periods without causing any appreciable reduction in transformer life.

Other limits that must be considered when operating the power system are the voltage limits.

## Voltage Limits

Voltage limits provide upper and lower voltage boundaries for operating the equipment and overall power system. The purpose of voltage limits is to maintain voltage levels on both transmission and customer connections.

- Exceeding the high-voltage limit may lead to overheating and over-excitation of the equipment.
- Operating the equipment below the low-voltage limit may cause motor loads to stall and may lead to voltage collapse.

Equipment manufacturers establish voltage limits for all equipment, including insulators, circuit breakers, generators, transformers, reactors, and capacitors.

Now let's examine how thermal and voltage limits affect power system stability.

## Section 9.5: Power System Stability

### Definition: Stability

**Stability** is a power system property that enables the synchronous machines of the system to respond to a disturbance so as to return to a steady-state condition. It is determined by the power system's ability to adjust its generators so that they remain synchronized following a power system load change or disturbance, such as the loss of a major transmission line, generator, or load.

### Definition: Synchronism

You may recall from previous modules that **synchronism** occurs when connected AC systems, machines, or a combination of the two operate at the same frequency and the voltage phase angle differences between systems or machines are stable at less than 90°.

In an unstable system, load changes or disturbances cause generators to speed up or slow down and consequently, to fall out of synchronism with the rest of the system. When a generator loses synchronism, it has to be tripped and re-synchronized, which places additional burden on the remaining generators.

### Definition: Instability

**Instability** results when two or more synchronous machines, systems, or parts of a system fail to remain in synchronism while electrically connected.

How do stability problems occur? Let's see.

## Stability Problems

Changes in the mechanical forces that drive generators occur much more slowly than power system electrical changes resulting from disturbances. When a disturbance occurs, the generating station's mechanical components have to play "catch up" to make the required adjustments.

From **Module 2: Fundamentals of Electricity**, we know that the power delivered to the system by a generator depends on the relative phase angle between the generator voltage and the system voltage.

A simplified equation for the power delivered to the system is:

$$\text{Power} = \frac{V_s V_r}{X} \sin \phi$$

Where:

- V<sub>s</sub> = sending-end voltage
- V<sub>r</sub> = receiving-end voltage
- Φ = phase angle between the V<sub>s</sub> and V<sub>r</sub>
- X = reactance of the line

- If the phase angle increases slightly, the power flow increases.
- Decreasing the phase angle causes the electrical power flow to decrease.

- However, under fault conditions, even though the phase angle may increase, power transfer may decrease on the line. This is due to an increase in reactance and a decrease in voltage.

When the relative phase angle reaches  $90^\circ$ , the electrical output of a generator starts to decrease as the angle increases. This is a key point in understanding the process of generator stability.

Under normal conditions, the mechanical power input (such as steam driving the turbine) is just enough to match the electrical load. Under this steady-state condition, the sending end voltage phase angle leads the receiving end voltage phase angle; the relative voltage phase angle is constant.

When the load increases, the following events occur:

- Generators momentarily slow down. This results in a small reduction in system frequency.
- To restore system frequency, the mechanical input to the turbine increases. The input must be greater than the steady-state load requirements, because the generators must be accelerated to a new and larger relative phase angle.
- Because the mechanical input is trying to catch up, it is momentarily greater than the electrical output.
- So when the desired phase angle is reached, the angle continues increasing until the mechanical input is slightly reduced.
- As the end result, the generators oscillate or "swing" around their steady-state point before eventually settling down.

A similar sequence of events occurs when the system load decreases. During power system disturbances, such as faults or the sudden loss of a generator, load, or major transmission line, significant generator oscillations can occur throughout the system.

- On a stable power system, generators are able to make the required adjustments to their mechanical input quickly enough that the oscillations gradually diminish and the generators return to steady-state.
- With an unstable system, oscillations for some generators increase with time, eventually resulting in over/underspeed conditions that cause these units to lose synchronism with the rest of the system. These units trip off-line. This further aggravates the disturbance and possibly causes other units to lose synchronism.
  - The end result can be as severe as the 1965 U.S. – Canadian Power System Outage, during which a major portion of the Northeastern U.S. and Canada was without electricity.

Similar to generators, the transfer of power between locations has the same characteristic as the electrical load on a generator.

Figure 9.3 illustrates the power-angle characteristic of a transmission line.

**Figure 9.3: Power Transfer**

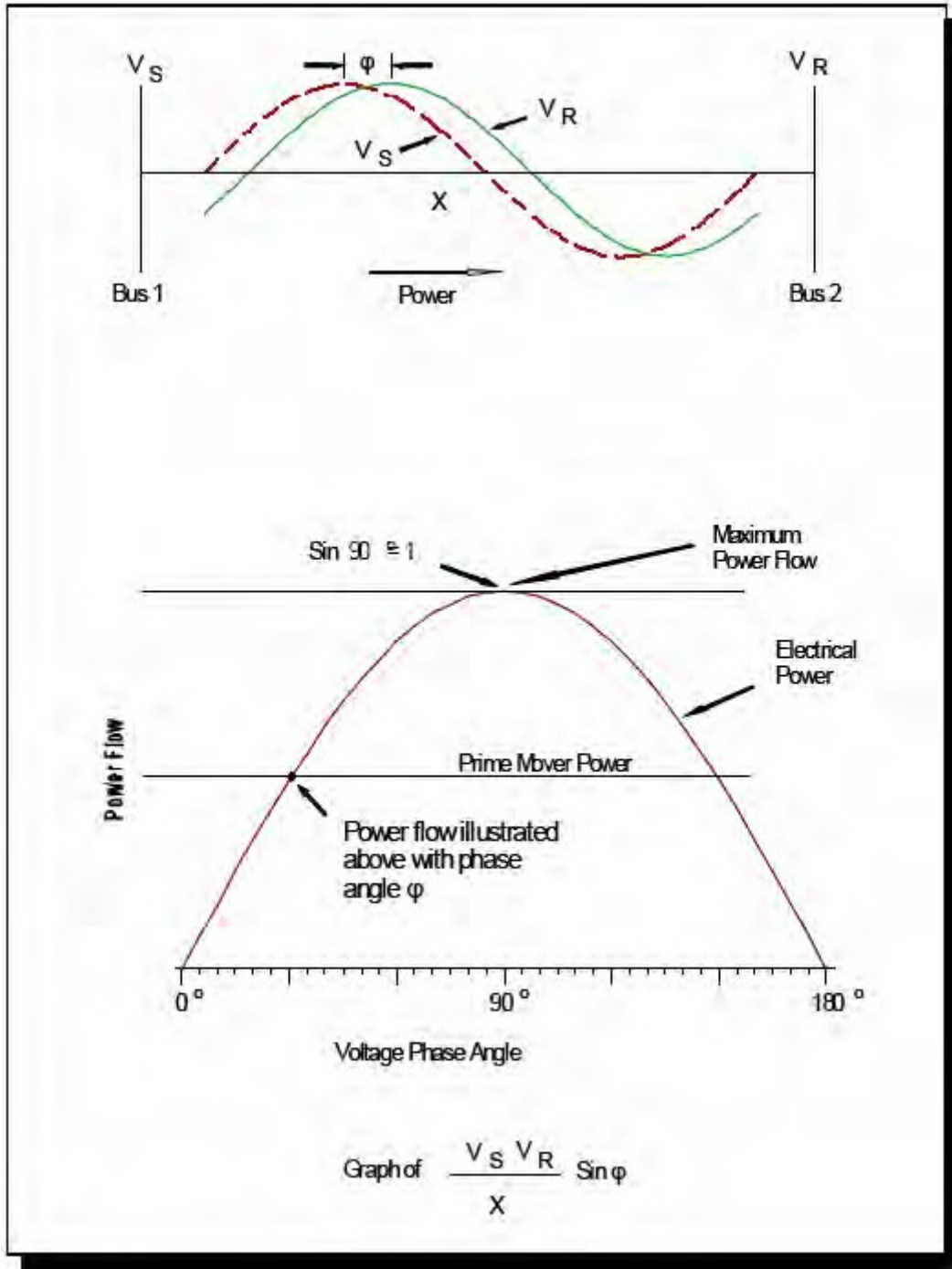

We know from our previous discussions in this module that in order to transfer power across a transmission line, there must be a difference in phase angle between the voltages at each end of the line. The more load that is transferred across the line, the greater the phase angle. Similar to a generator, there is a maximum power transfer. Theoretically, this occurs when the phase angle between the two buses is  $90^\circ$ . In practice the actual value is below this.

Any attempt to transfer power beyond the maximum value results in an actual decrease in power transferred. This causes the generators at either end of the system to electrically drift apart and lose synchronism.

The transferred power flows over several parallel circuits. The magnitude of power carried by any one circuit is determined by the reactance of the circuit relative to the reactance of the other parallel paths.

For example: If line 1 has twice the reactance of line 2, line 1 carries half the power. So when a line unexpectedly trips, there must be enough capability on the parallel paths to handle the resulting changes in flow.

Electric power systems generally remain stable, even following severe faults at major generating stations. Stability problems can arise during unusual multiple contingencies, such as when faults occur nearly simultaneously on two major transmission lines.

### **Definition: Special Protection Systems (SPS)**

Many utilities incorporate protection systems called ***special protection systems*** or remedial action schemes. These monitor certain critical facilities and, when necessary, initiate switching actions and adjustments to generator loading when certain contingencies occur. We discuss special protection systems in more detail in ***Module 8: System Protection***.

Utilities also install series capacitors to allow more real power to flow at a reduced relative phase angle. Series capacitors cancel or compensate for some of the line's inductive reactance. Thus, they decrease the impedance and improve stability.

### **Definition: Stability Limit**

The maximum amount of power that can be transferred across a system is called the ***stability limit***.

- If the power transfer is below the stability limit, the system is stable.
- If the power transfer is above the stability limit, the system is unstable.

## Stability Conditions

Three stability conditions exist:

- Steady-state
- Transient
- Dynamic

It is beyond the scope of this manual to cover each of the stability conditions in detail. Instead we provide general definitions of each.

### Definition: Steady-State Stability

**Steady-state stability** is a power system's ability to maintain synchronism between parts of the system during normal load changes. It also refers to the power system's ability to damp out any oscillations caused by such changes.

### Definition: Transient Stability

**Transient stability** is a power system's ability to maintain synchronism between system parts when subjected to a fault of specified severity.

### Definition: Dynamic Stability

**Dynamic stability** is a power system's ability to maintain synchronism between system parts after the initial swing (during the transient stability period) until the system settles down to a new, steady-state condition.

Utilities establish their own guidelines for operating the power system within stability limits but guidelines generally include the following functions:

- Adhere to actual line loading limits and path scheduling limitations (i.e., the maximum scheduled interchange is not greater than the transfer capability).
- Use series compensation methods, as appropriate.
- Monitor system conditions, including line loadings, generation changes, and line conditions.
- Carefully analyze the effect of planned equipment outages and adjust system operations accordingly.
- Keep remedial action schemes and protection schemes in-service as much as possible.
- Keep power system stabilizers in-service.
- Follow established operating procedures.
- Be prepared to shed load, as necessary.
- Exchange operating information with adjacent systems.

## Subsynchronous Resonance

You may recall from **Module 7: Power Transmission**, that utilities improve system stability by inserting series capacitors in a transmission line. The series capacitors cancel some of the line's inductive reactance. This allows more real power to flow. When this is done, the capacitance of the capacitor bank may interact (resonate) with the transmission line's inductance and produce electrical oscillations with frequencies between 10 and 50 Hz.

These oscillations are called subsynchronous since they are less than the normal 60 Hz frequency of the rotating machine. When these electrical resonances occur on the system, currents at the subsynchronous frequency flow into the stators of the generators. These currents produce torsional stresses in the generating unit shafts.

### Definition: Subsynchronous Resonance

If the damping from the electrical resistance in the system and steam in the turbines is insufficient, or if the electrical system is heavily stressed, the subsynchronous oscillations build up. This is called **subsynchronous resonance**. Shearing of the turbine-generator shaft can occur as a result of subsynchronous resonance.

Utilities use several methods to prevent and/or control subsynchronous resonances, including:

- minimizing the use of series capacitors by implementing other methods of improving power system stability
- implementing operating procedures that bypass series capacitors when the power system is in a contingency condition
- installing special relays or filtering devices that block low frequency currents from entering a generator

## Section 9.6: Computer System Functions

Many utilities have computer systems that allow the system operators to monitor, control, study, and coordinate the operation of the power system. The computer systems are capable of performing many different functions. The functions are implemented with the following computer programs:

- Supervisory Control and Data Acquisition
- Automatic Generation Control

- Economic Dispatch
- Unit Commitment
- Interchange Transaction Scheduling
- Hydroelectric Coordination
- Hydrothermal Coordination
- Power System Analysis
- Information Storage and Retrieval

Many other functions are available to match the needs of the individual utilities. This section focuses on the ones listed above which are the more common functions.

## Supervisory Control and Data Acquisition

### Definition: Supervisory Control and Data Acquisition (SCADA)

**Supervisory control and data acquisition (SCADA)** is a combination of a telecommunications system, computer hardware, and software programs that collect data — such as generator and transmission line loadings and circuit breaker statuses — and transmits this information to a central location where it can be viewed or used by various application programs.

SCADA also allows the system operator to select and control various remotely located power system devices. For example; system operators may be able to open and close selected circuit breakers and adjust transformer taps.

## Automatic Generation Control

### Definition: Automatic Generation Control (AGC)

An **automatic generation control (AGC)** program regulates the power output of electric generators within a prescribed Balancing Authority in response to changes in system frequency and tie line loading. The primary objectives of AGC are:

- to hold system frequency as close as possible to the desired frequency
- to maintain the correct power interchange values between Balancing Authorities
- to provide generation at the most economic value

After determining the desired generation for each unit, the AGC system signals the unit turbine governor controllers to raise or lower their outputs.

The AGC program may not control all generating units. For units not on control, the system operator contacts the plant operator to specify the desired loading. The plant operator then manually adjusts unit loadings to the appropriate values.

## Economic Dispatch

### Definition: Economic Dispatch

An ***economic dispatch (ED)*** program achieves optimum system economy by distributing the total generation requirements among generating units that are currently on-line.

In determining the most economical load for each available unit, ED programs take into account:

- Relative production costs for each unit
  - Production costs are influenced by unit efficiency and fuel cost.
  - In general, more efficient units are loaded more heavily than less efficient units.
- Electrical losses incurred while transferring power over the transmission system to the load
  - Generating units that are closest to the load centers or connected to transmission lines operating at the highest available voltages experience lower transmission losses.
  - Remote generating stations and stations served by lower voltage lines experience higher transmission losses.

## Unit Commitment

### Definition: Unit Commitment

A ***unit commitment (UC)*** program determines the best combination of generating units for satisfying the expected load requirement over a specified period. The UC program determines which units should be on-line to minimize total system production costs.

UC programs consider many factors in deciding which units to run, including:

- capacity of available units  
Is the capacity adequate to satisfy the anticipated load and reserve requirements?
- time required to bring a unit on-line  
When it is anticipated that a unit with a lengthy start-up process will be needed, the process must be started in advance.
- minimum run time  
Some units must run for a specified minimum time period before being shut down. These units should not be started up to satisfy a peak load requirement of short duration.
- minimum shut-down time  
Some units have to stay off-line for a period of time after being shut down. These units should not be taken off-line if they will be needed again soon.

## Interchange Transaction Scheduling

### Definition: Interchange Transaction Scheduling

An ***interchange transaction scheduling (ITS)*** program keeps track of all agreements to buy and sell power with neighboring systems. This can include transactions currently in progress and transactions scheduled for the future.

## Hydroelectric Coordination

### Definition: Hydroelectric Coordination

A ***hydroelectric coordination*** program is a dispatch program for hydroelectric units. It considers the following factors:

- supply of water
- environmental constraints

Hydro plants sharing the same river system require coordinated dispatch. The water outflow from one plant might be a very significant part of the inflow to the next plant downstream. Water used by one plant takes time to flow downstream to the next plant.

## Hydrothermal Coordination

### Definition: Hydrothermal Coordination

A **hydrothermal coordination** program optimizes the mix of hydro and thermal generation to meet the system load in the most economical way within the following constraints:

- Water availability
- Minimum flow requirements
- Other environmental or operating issues

In general, the lowest cost method of operating a hydrothermal system is to use all the hydro energy available and minimize the amount of fuel burned in the thermal units.

## Power System Analysis

### Definition: Power System Analysis

The **power system analysis** functions provide the system operator with tools to monitor power system security. The power system analysis applications include the following functions:

- State estimation
- Contingency analysis

Each of these functions uses a power system model that provides a computer database description of the power system.

State estimation combines the real-time system data with the power system model to estimate the current power system condition. It is also used to identify telemetered data that may be in error.

Contingency analysis examines "what if" power system troubles before they occur. Again, this program uses the power system model to study outage events and alarms the system operators of potential overloads or voltage problems. The contingency analysis results enable the system operator to operate the power system defensively.

## Information Storage and Retrieval

The information storage and retrieval function collects and stores data periodically and upon power system disturbances. The data consists of accumulator, analog, and status point values that are telemetered, operator-entered, and calculated. Calculations are performed on the stored data and the results are then stored. Alarms, events, and reports are also stored. This information is made available to operators and engineers to use in operating and studying the power system.

**Conclusion:** This concludes the module on principles of power system operation. The module presents some methods of monitoring and controlling the power system. You should review the methods and operating practices in use at your utility.

**This page intentionally left blank.**

**Module 9:  
Principles of Power System Operation  
Question Set**

**Module 9:  
Principles of Power System Operation  
Question Set**

- 9.1** True/False: When the system is over-generating (supply > demand), the frequency decreases below 60 Hz.
- 9.2** Describe the effect of frequency excursions on electric clocks.
- 9.3** What is spinning reserve?
- 9.4** What is loop flow?

**9.5** List and define three system control modes.

**9.6** Answer the following questions about inadvertent:

**(a)** What is inadvertent?

**(b)** What does inadvertent indicate?

**(c)** List two causes of inadvertent.

**9.7** Define stability.

**9.8** List and describe three stability conditions.

**9.9** Match the computer system function in Column 1 with its definition in Column 2. (A – H)

<b>Column 1</b>	<b>Column 2</b>
_____ Supervisory Control and Data Acquisition (SCADA)	A. Program that regulates the power output of electric generators within a prescribed Balancing Authority in response to changes in system frequency and tie line loading.
_____ Automatic Generation Control (AGC)	B. Program that achieves optimum system economy by distributing the total generation requirements among generating units that are currently online.
_____ Economic Dispatch (ED)	C. Functions that provide tools to monitor power system security and include state estimation and contingency analysis.
_____ Unit Commitment (UC)	D. Program that keeps track of all agreements to buy and sell power with neighboring systems.
_____ Interchange Transaction Scheduling (ITS)	E. Telecommunications system that collects data and transmits this information to a central location where it can be viewed or used by various application programs.
_____ Hydroelectric Coordination	F. Program that determines the best combination of generating units for satisfying the expected load requirements over a specified period.
_____ Power System Analysis	G. Dispatch program for hydroelectric units.
_____ Hydrothermal Coordination	H. Program that optimizes the mix of hydro and thermal generation to meet the load.

This page intentionally left blank.



## **Glossary and References**

## Glossary and References

<b>Glossary.....</b>	<b>3</b>
<b>References.....</b>	<b>16</b>